



Rock Rage Rear Bumper

Parts Included	Qty
Rear Bumper	1
Backing Plates	4
3/8" x 1 1/4" Hex Bolts	8
3/8" Flat Washers	8
3/8" Lock Washers	8
7/16" x 1 1/4" Hex Bolts	2
7/16" Flat Washers	2
7/16" Lock Washers	2

NOTE: Carefully read entire instructions thoroughly before attempting to assemble and/or install this product.

IMPORTANT INFORMATION:

- Will accommodate up to a 35" Spare tire.
- Factory bumper and tire carrier will need to be removed to install the carrier.
- The 3rd brake light will need to be relocated. Location may vary due to tire size.
- This bumper is NOT RATED FOR TOWING.

Installation Instructions

1) Remove factory bumper, if equipped.

2) (85-96 YJ, 97-TJ's) -Locate (2) Backing Plates, (4) 3/8" Hex Bolts, (4) 3/8" Flat Washers, and (4) 3/8" Lock washers. With a helpers assistance place backing plates to the rear of the vehicle frame. Align holes in rear plate on the bumper to those existing holes in the frame. Loosely attach to one side of vehicle with the hardware listed in this step. Repeat on opposite side; loosely attach bolts at this time.

(98-On TJ's)- On these models the inner frame mounting holes will need to be drilled. In order to do this it is recommended to drop the gas tank in order to gain access to the area. This should be done by a trained mechanic.

Note: Use extreme caution when working near and with the fuel tank.

Template Instructions:

- A) Raise the frame drill template **into** place by locating it on the rear frame cross member **OE** bumper outer mounting holes.
NOTE: The notch will be on the top and the drill template will be flipped for use on both the driver and passenger side.
- B) Using the supplied drill template, making sure its straight mark the needed holes with a scribe or marker then proceed to drill the (4) holes in the frame using a 7/16" drill bit.

CAUTION! Be VERY CAREFUL not to drill into the fuel tank. Use a drill stop on the drill bit to prevent the drill bit from over penetrating.

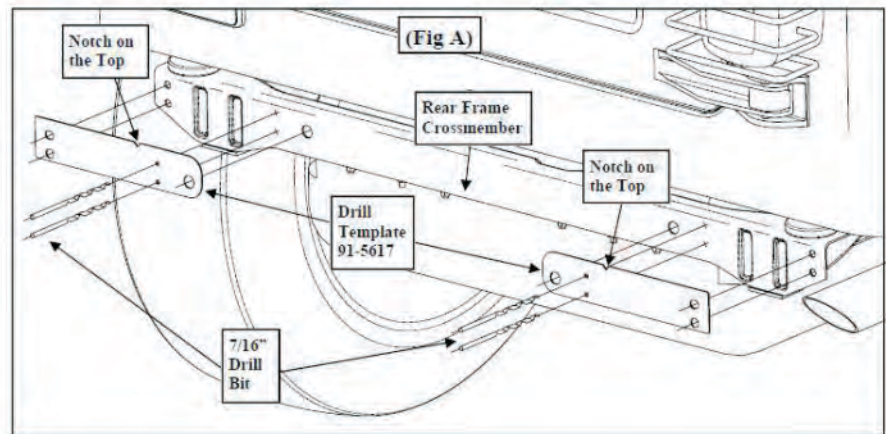

If no template is available, use the following instructions:

Measure the distance carefully from hole to hole on the back of your bumper and the match and mark these measurements on the rear frame rail or you can mount the bumper using the outside holes and use the inner holes as a guide to where to drill. Once holes are marked; with caution drill out using a 7/16" drill bit.

Once holes are drilled you can mount your bumper (loosely) making sure backing plate are on the inner and outer holes behind the frame rail.

- 3) Align the lower mount brackets (one per side) with the holes on the bottom of the frame. Using (1) 7/16" Hex Bolt, (1) 7/16" Flat Washer, and (1) 7/16" Lock Washer attach and secure the bottom bracket to the frame. **Note:** if equipped, the factory bolt can be used in this step. Repeat on opposite side.
- 4) Tighten all hardware completely at this time. Follow the tire carrier instructions to install the tire carrier portion of this bumper.

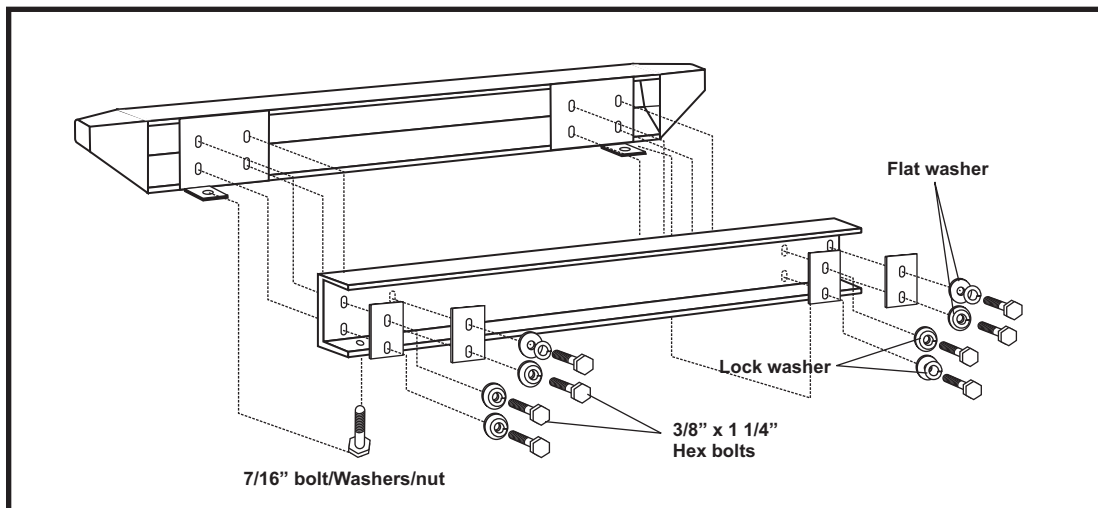



Tire Carrier

Parts Included	Qty	Parts Included	Qty
Tire Carrier	1	3/8"-16 x 2.5" Hex Head Bolt	1
Top Post	1	3/8" x 1 1/8" Hex Head Bolt	2
Tire Mount	1	3/8" x 1 3/8" Hex Head Bolt	1
Nylon Ring	1	3/8" Flat Washer	12
Circle Clip	1	3/8" Lock Nut	5
Rubber Spacer	1	3/8" x 1 Hex Head Bolt	2
#10 x 1" Sheet Metal Screw	1	3/8"-16 Lock Nut (coarse thread)	2
Lug Nut	3		
Quick clip	1		

Installation Instructions

- 1) Insert nylon washer down over post on bumper. Install tire carrier down post and secure latch. Secure tire carrier to post using (2) 3/8" x 1" bolts, (4) flat washers, and (2) lock nuts. Now install the circle clip to the top of the post.

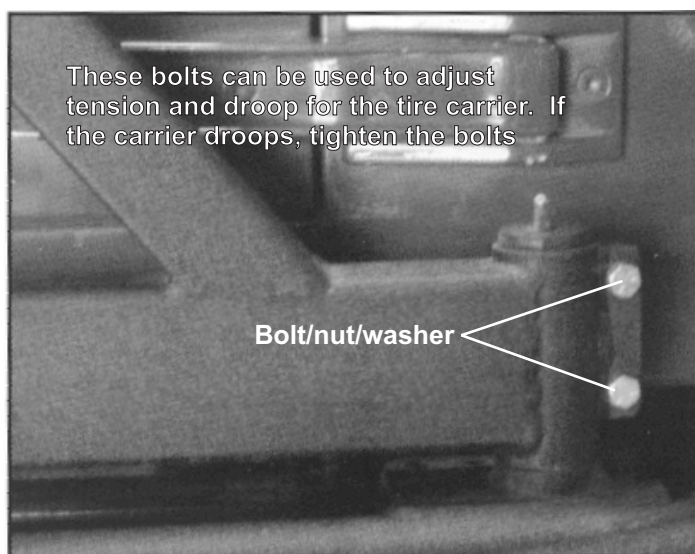
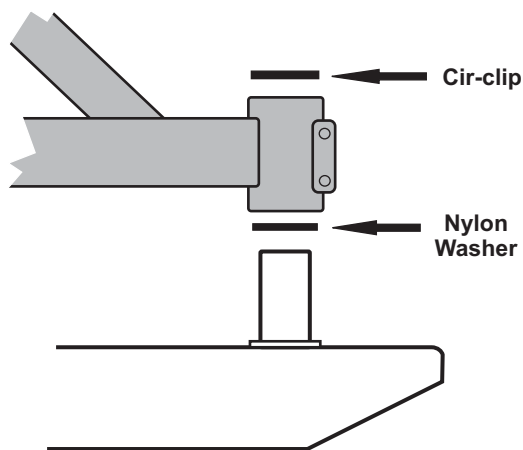

- 2) Insert top post onto top of the tire carrier. Secure with The 3/8" x 2.5" bolt, washer and nut.

The top post slides down into carrier.

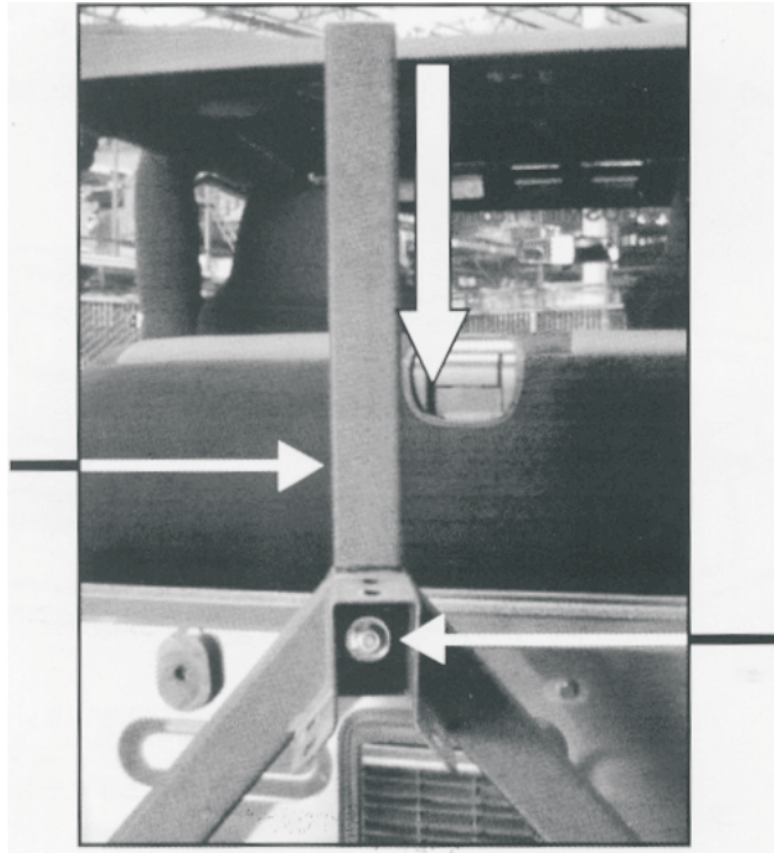

(1) 3/8"-16 x 2.5" Hex Head Bolt
(2) 3/8" Flat Washers
(1) 3/8" Nylock Nut

- 3) Locate mounting bracket, (3) 3/8" x 1" hex head bolts, (6) 3/8" flat washers, (3) lock nuts. Slide tire support bracket onto tire carrier as shown below. Now secure with the hardware. **Note:** There are 2 sets of holes on the tire carrier to allow mounting of oversized tires. Now install tire on mount and secure with included lug nuts. **Note:** For some custom wheels the included lug nuts may not work.
- 4) To help eliminate and reduce any movement of the tire carrier it is recommended to install the included rubber spacer on the back of the tire carrier. Select a good location on the back of the tire carrier so when closed the spacer hits flush against the back of the vehicle. Installation is now complete.

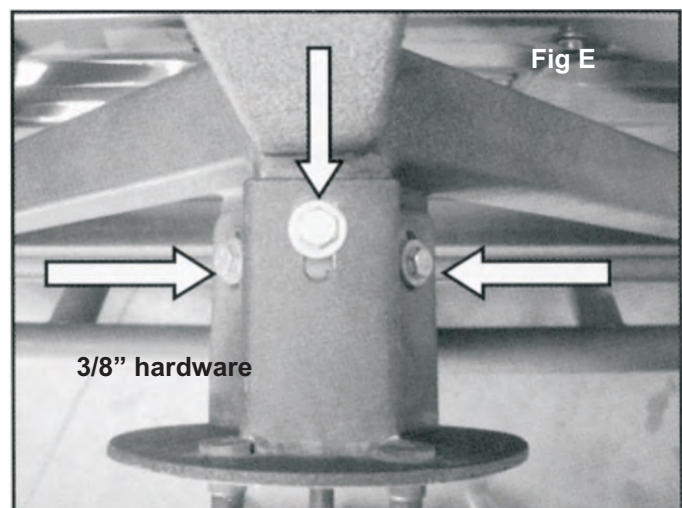
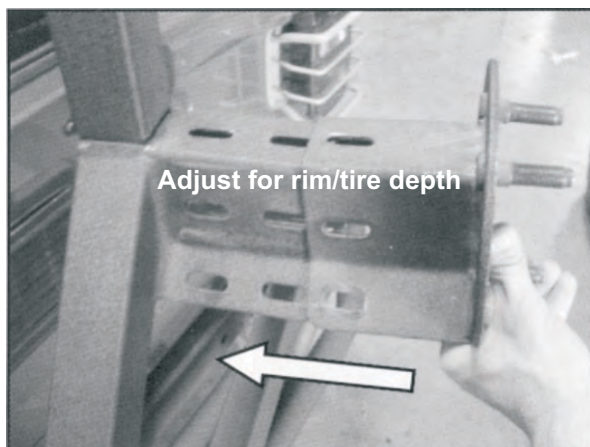

Note: Secure latch by inserting included quick clip in the top hole of the latch extending all the way through the back of the tire carrier, then secure with loop.

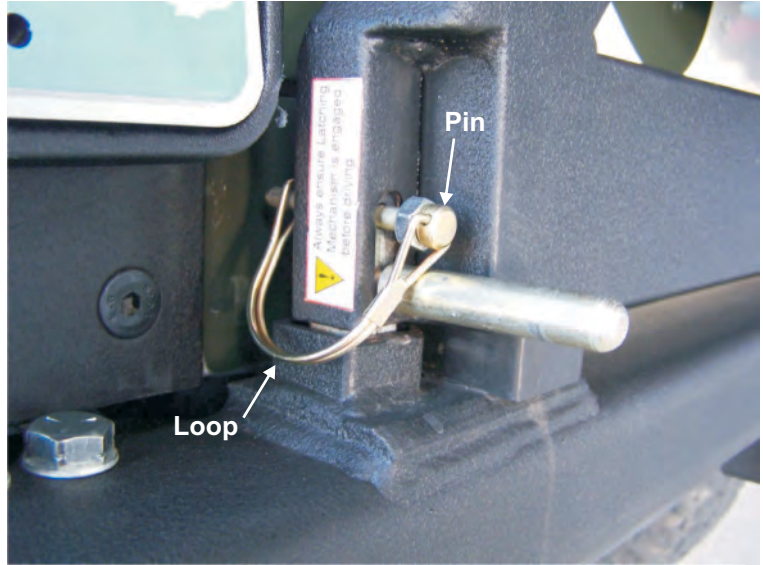

Rampage (the company) warrants to the original purchaser of this product that should the product or any part thereof, under normal use and conditions, be proven defective in material or workmanship within 12 months from date of original purchase, such defect(s) will be repaired or replaced (at the Company's option) without charge for parts or repair labor. Please note that installation labor to remove or install this product is not covered under this limited warranty.

To obtain repair or replacement within the terms of this Warranty, the product is to be delivered with proof of warranty coverage (e.g. dated bill of sale), specification of defect(s), freight pre-paid to the place of purchase or, you must contact Rampage Products at the number below for warranty service or to obtain a Return Goods Authorization Number.

NOTE: Items returned to Rampage Products without an Authorized Returns Good Authorization number will be refused and returned back to sender at the sender's expense.

This warranty does not apply to any product or part thereof which, in the opinion of the Company, has suffered or been damaged through alteration, improper installation, mishandling, misuse, neglect, accident or by acts of nature. THE EXTENT OF THE COMPANY'S LIABILITY UNDER THIS WARRANTY IS LIMITED TO THE REPAIR OR REPLACEMENT PROVIDED ABOVE AND, IN NO EVENT, SHALL THE COMPANY'S LIABILITY EXCEED THE PURCHASE PRICE PAID BY PURCHASER FOR THE PRODUCT.

This warranty is in lieu of all express warranties or liabilities. ANY IMPLIED WARRANTIES, INCLUDING ANY IMPLIED WARRANTY OF MERCHANTABILITY, SHALL BE LIMITED TO THE DURATION OF THIS WRITTEN WARRANTY. ANY ACTION FOR BREACH OF ANY WARRANTY HEREUNDER INCLUDING ANY IMPLIED WARRANTY OF MERCHANTABILITY MUST BE BROUGHT WITHIN A PERIOD OF 12 MONTHS FROM ORIGINAL PURCHASE. IN NO CASE SHALL THE COMPANY BE LIABLE FOR ANY CONSEQUENTIAL OR INCIDENTAL DAMAGES FOR BREACH OF THIS OR ANY OTHER WARRANTY, EXPRESS OR IMPLIED, WHATSOEVER. No person or representative is authorized to assume for the Company any liability other than expressed herein in connection with the sale of this product.

Some states do not allow limitations on how long an implied warranty lasts or the exclusion or limitation of incidental or consequential damage, therefore above limitations may not apply to you. This Warranty gives the purchaser specific legal rights. The purchaser may have additional rights, which vary from state to state.

**Rampage Products, Inc.
Buford, GA
Phone: 800-328-2409
www.rampageproducts.net**