

Installation Instructions

I-Sheet Number: TM-03 Rev C



Trail Ram Center Bull Bar

**For proper installation and best possible fit, please read all instructions BEFORE you begin.
For technical assistance or to obtain missing parts, please call Customer Relations at 1-800-241-7219.**

Important Safety Information



- CAUTION - Before driving, ensure that the bumper is properly anchored to vehicle.
- Periodically check all components for tightness.

Contents

- (1) Bull Bar
- (4) 5/8" Bolts
- (4) 5/8" Flat Washers
- (4) 5/8" Nylon Locking Nuts

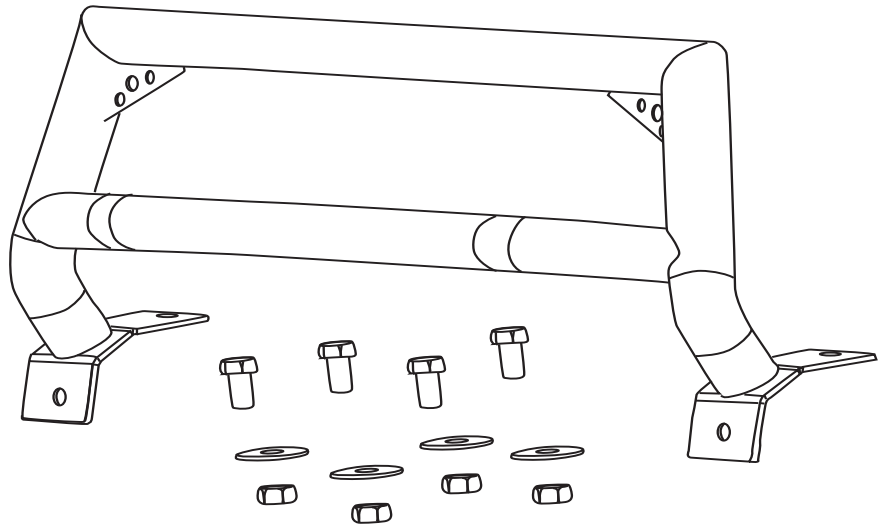

Tools Required



Marking tool

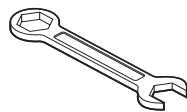

Wrench



Safety Glasses

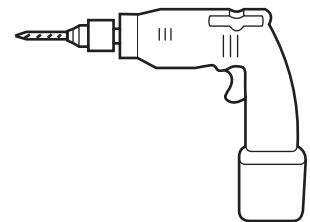

Drill

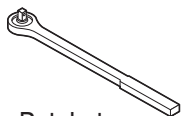

Ratchet



Standard Socket

Center Punch

Preparation Before Installation

- A test fit is recommended to ensure proper positioning and fit.
- Check fit of parts before painting as we will not accept the return of modified or painted parts.
- Remove contents from the box and check for missing pieces or damage. If parts are missing or damaged, please contact original place where item(s) were purchased.

Installation Steps

Place the Bull Bar onto the front bumper

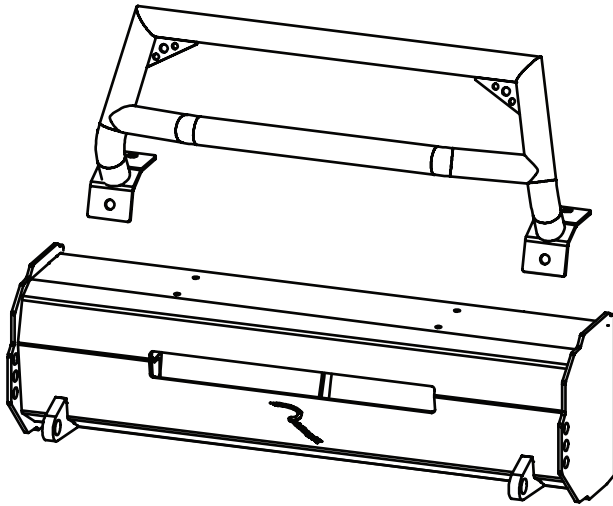

1

Use a center punch to mark drill locations and begin drilling the four holes in the bumper. It will be faster and easier to begin with a small diameter bit and work your way up to a 5/8" drill bit for the final diameter.

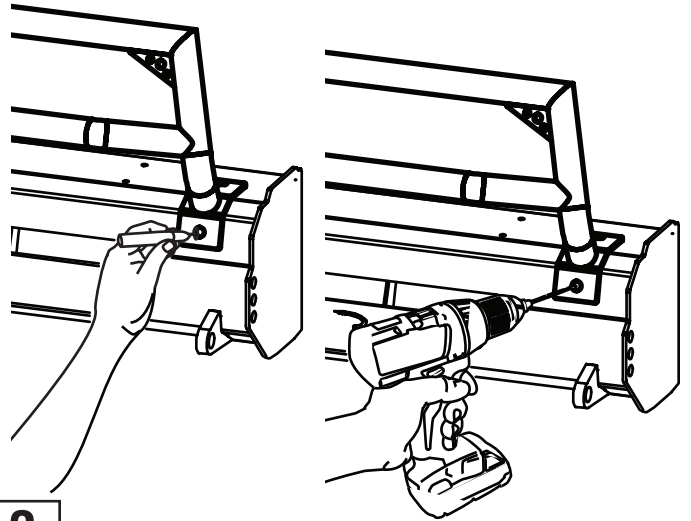

2

Install the 5/8" hardware as shown in the diagram below.

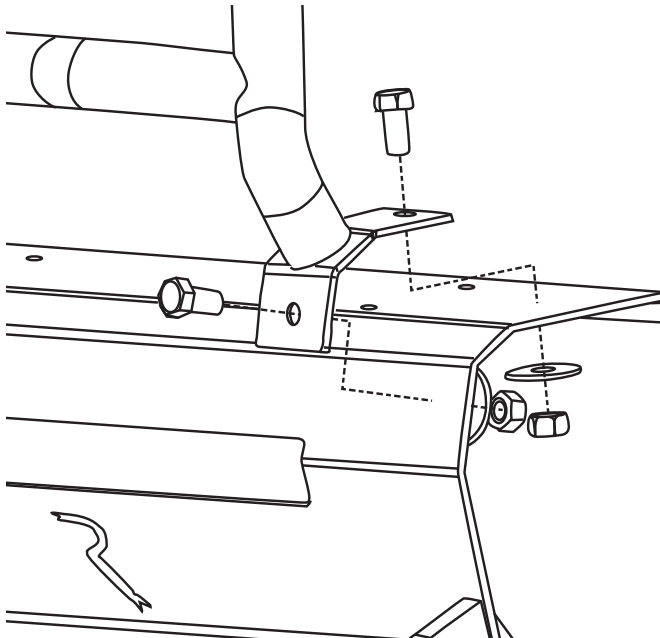

3

Once all hardware is installed, tighten evenly to complete installation.

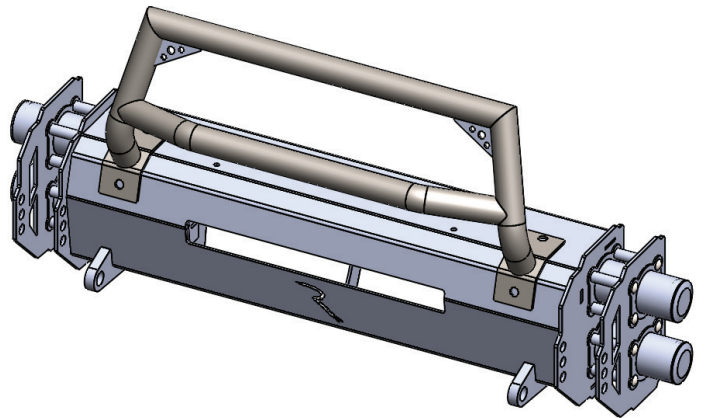

4

Congratulations!

You have purchased one of the many quality Rampage® branded products offered by Lund International, Inc. We take the utmost pride on our products and want you to enjoy years of satisfaction from your investment. We have made every effort to ensure that your products is top quality in terms of fit, durability, finish and ease of installation.



Lund International
800-241-7219 • Visit us at lundinternational.com
© 2015 Lund International, Inc. All rights reserved.
Lund® and the logo Lund® are trademarks of Lund International, Inc.





Trail Ram Center Bull Bar

Pour une installation correcte et un ajustement optimal, veuillez lire toutes les instructions AVANT de débiter. Pour de l'assistance technique ou pour obtenir des pièces de rechange, veuillez communiquer avec le service à la clientèle au 1-800-241-7219.

Informations importantes de sécurité



- ATTENTION - Avant de prendre la route, veuillez vous assurer que le pare-chocs est bien ancré au véhicule.
- Vérifiez périodiquement toutes les composantes pour vous assurer qu'elles sont bien fixées.

Contenu

- (1) Barreau pour Pare-chocs
- (4) Boulons 5/8"
- (4) Rondelles plates 5/8"
- (4) Ecrou verr. nylon 5/8"

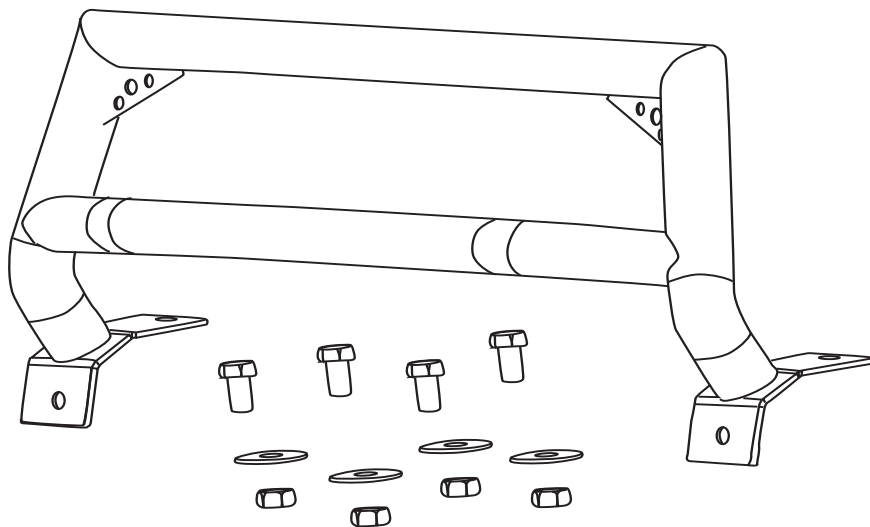

Tools Required

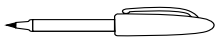

Outil de marquage

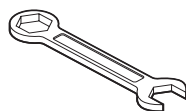

la clé anglaise



des lunettes

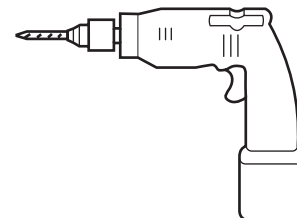

percer

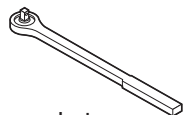

rochet



Prise

Poinçon central

Préparation avant l'installation

- Un ajustement d'essai est recommandé afin de s'assurer que le positionnement et l'ajustement sont adéquats.
- Vérifiez l'ajustement et les pièces avant de peindre, car nous n'accepterons pas le retour de pièces peintes ou modifiées.

Étapes d'installation

Placez la barre Bull sur le pare-chocs avant

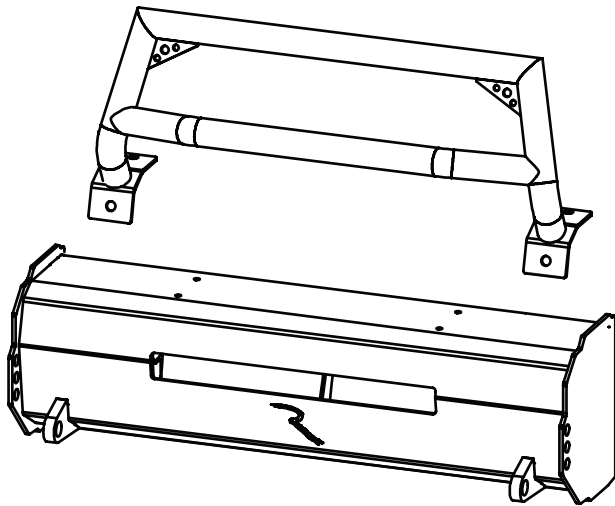

1

Utilisez un poinçon central pour marquer les emplacements de perçage et commencer à percer les quatre trous dans le pare-chocs. Il sera plus rapide et plus facile de commencer avec un peu de petit diamètre et de travailler votre chemin jusqu'à un foret de 5/8 "pour le diamètre final.

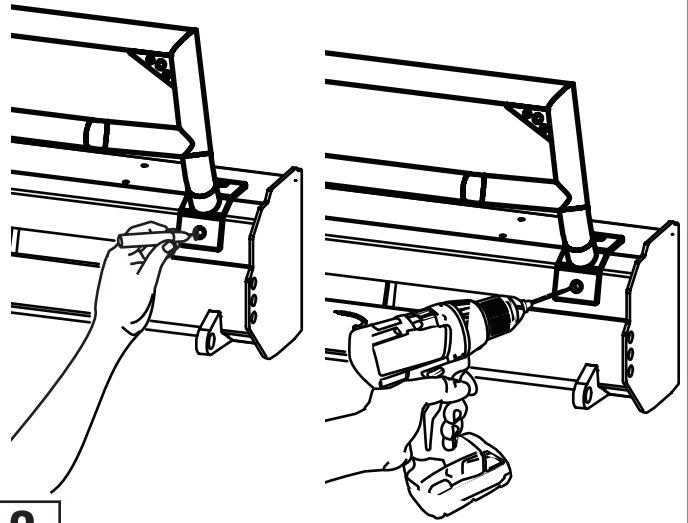

2

Installez le matériel 5/8 "comme indiqué dans le schéma ci-dessous.

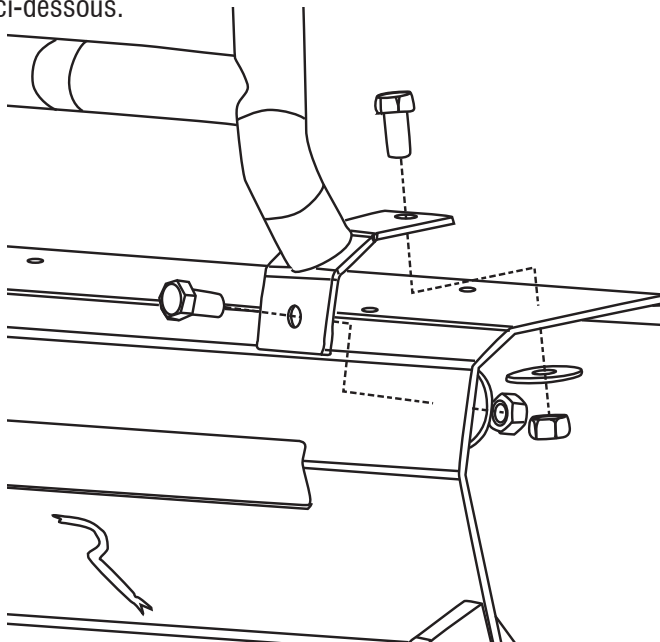

3

Une fois que tout le matériel est installé, serrez uniformément pour terminer l'installation.

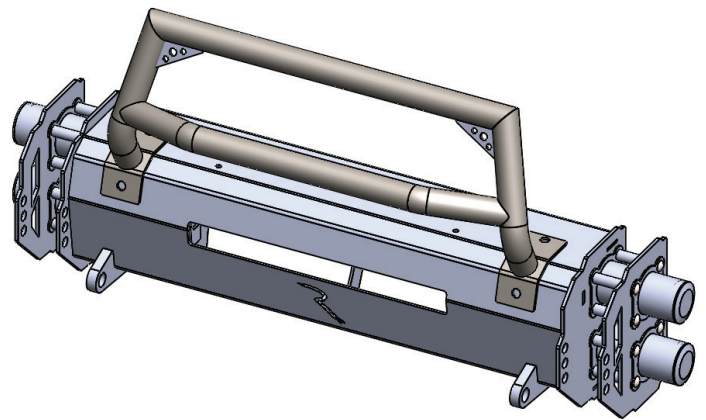

4

Félicitations!

Vous avez acheté l'un des nombreux produits de qualité de marque Lund® offerts par Lund International, Inc. Nous sommes fiers de nos produits et souhaitons que vous profitiez de votre investissement pendant des années. Nous faisons tout en notre pouvoir pour nous assurer que nos produits sont de qualité exemplaire en termes d'ajustement, de durabilité, de fini et de facilité d'installation.



Lund International
800-241-7219 • Visitez-nous à lundinternational.com
© 2015 Lund International, Inc. Tous droits réservés.
Lund® et le logo Lund® est une marque de commerce de Lund International, Inc.





Trail Ram Center Bull Bar

Para una instalación adecuada y el mejor ajuste posible, lea todas las instrucciones ANTES de comenzar. Si desea recibir asistencia técnica o para obtener piezas faltantes, llame al Servicio de cliente al 1-800-241-7219.

Información importante de seguridad



- PRECAUCIÓN - Antes de conducir, asegúrese de que la cubierta para capó esté correctamente anclada al vehículo.
- Compruebe periódicamente que todos los componentes estén ajustados.

Contenido

- (1) Barra para el parachoques
- (4) Boulons 5/8"
- (4) Rondelles plates 5/8"
- (4) Ecrou verr. nylon 5/8"

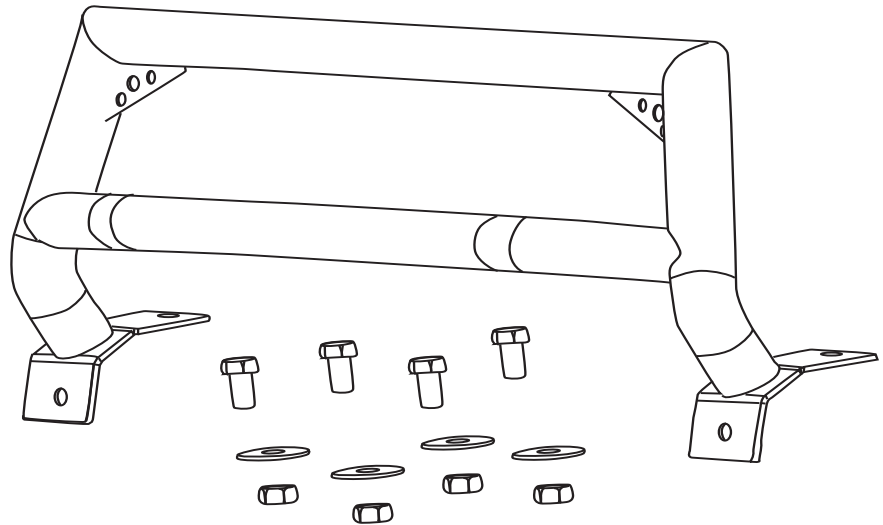

Tools Required

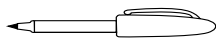

Herramienta de marcado

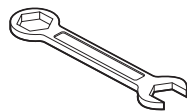

Llave inglesa



Lentes de seguridad



Trinquete



Zócalo estándar

Centre Punch

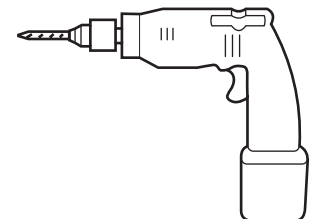

Perforar

Preparación antes de instalar

- Se recomienda un ajuste de prueba para garantizar que la colocación y el ajuste son adecuados.
- Verifique el ajuste y partes antes de pintar, como no acepterans no la devolución de piezas modificadas o pintadas.

Pasos de instalación

Coloque la barra de Bull sobre el parachoques delantero.

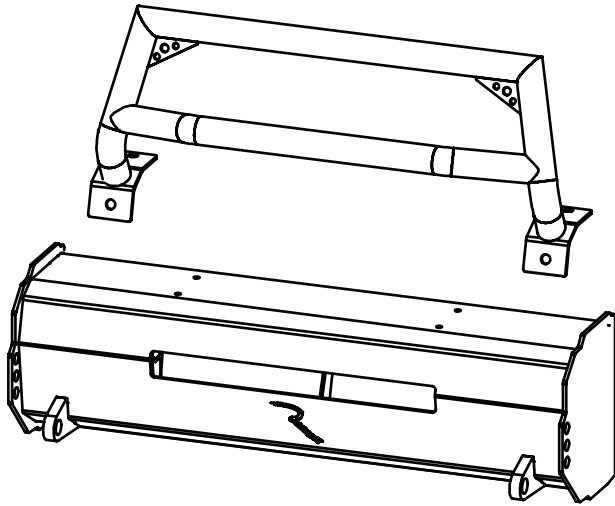

1

Utilice un punzón para marcar los lugares de perforación y comenzar a perforar los cuatro orificios en el parachoques. Será más rápido y más fácil comenzar con un poco de diámetro pequeño y trabajar su camino hasta una broca de 5/8 "para el diámetro final.

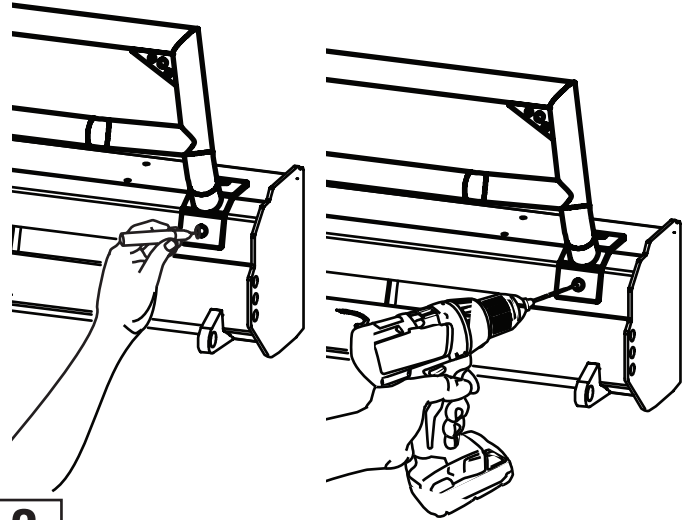

2

Instale el hardware de 5/8 " como se muestra en el siguiente diagrama.

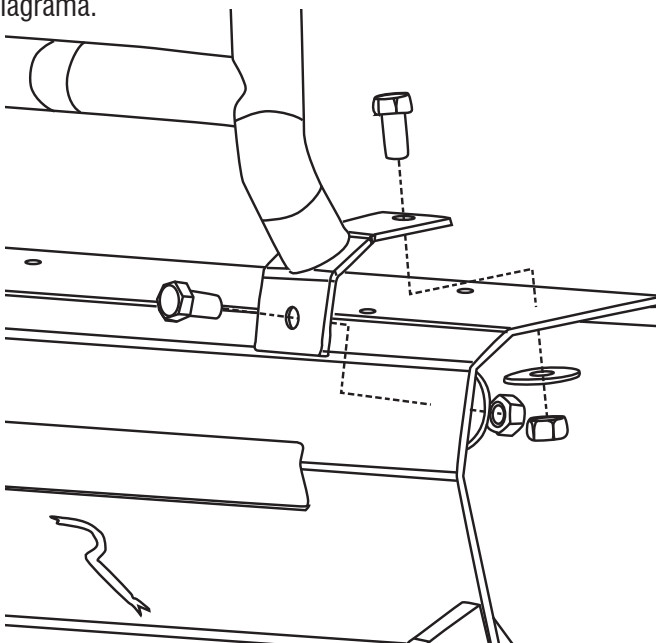

3

Una vez que todo el hardware esté instalado, apriételo uniformemente para completar la instalación.

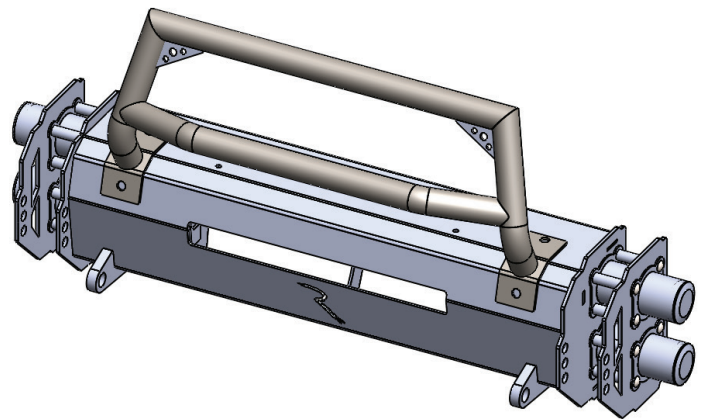

4

Felicidades!

Usted ha comprado uno de los muchos productos de marca Lund® de calidad ofrecidos por Lund International, Inc. Nos sentimos orgullosos de nuestros productos y queremos que disfrute de años de satisfacción con su inversión. Hemos hecho todo lo posible para asegurar que sus productos son de primera calidad en términos de ajuste, durabilidad, y facilidad de instalación.



Lund International
800-241-7219 • Visite nuestro sitio Web: lundinternational.com
© 2015 Lund International, Inc. Todos los derechos reservados.
Lund® y el logo de Lund® son marcas registradas de Lund International, Inc.

