

INSTALLATION SHEET

Any damaged or missing parts?

Parts will be shipped to you directly.

Call 1-800-952-7655 Mon-Fri 8am - 5pm EST

or email info@rollnlock.com

NOTE: Installation is the same for both standard track and XT Series track

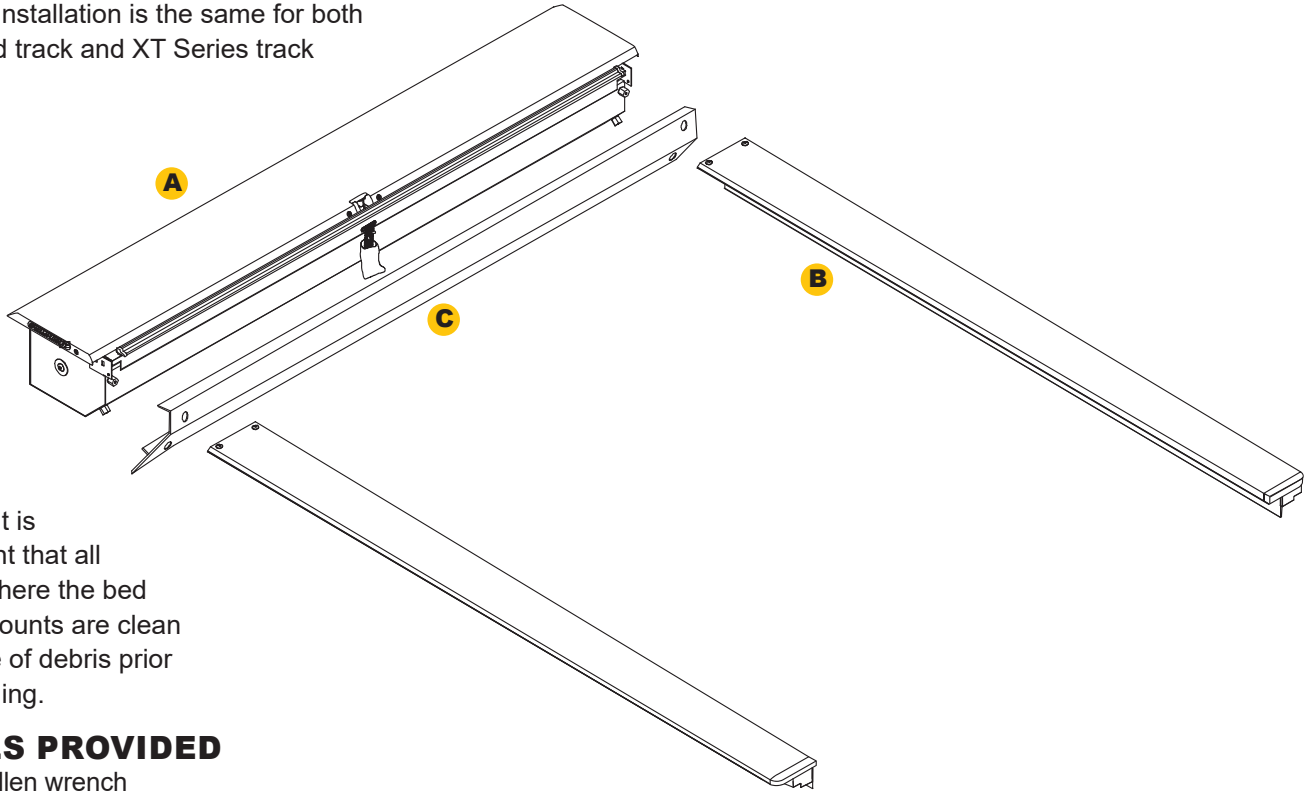

NOTE: It is important that all areas where the bed cover mounts are clean and free of debris prior to installing.

TOOLS PROVIDED

- 1/4" Allen wrench
- 4mm Allen wrench
- 303® Vinyl protector

TOOLS REQUIRED

- Jig saw
- Phillips screwdriver
- Tape measure
- Drill with Phillips head
- 5/8" Box wrench
- Ratchet with 8mm socket

PARTS INCLUDED IN YOUR KIT

- A** 1x Housing
 - B** 2x Track
 - C** 1x Cargo shield
 - D** 2x Drain tube
 - E** 4x Bed clamp (6x 6'4"ft Bed)
 - F** 2x #10-24 Screw
 - G** 2x Cargo nut
 - H** 6x 5/16" x 1" Cap screw (8x 6'4"ft Bed)
 - I** 6x 5/16" Lock washer (8x 6'4"ft Bed)
 - J** 2x 5/16" Flat washer
 - K** 4x 1-3/8" x 3/8" Shim
 - L** 2x 3" x 3" Track angle
 - M** 2x 1/8" Thick bed clamp shim
 - N** 4x 1/16" Thick bed clamp shim
 - O** 2x 6mm x 40mm Bolt
 - P** 2x M6 washer
 - Q** 4x 1/4-20 x 3/8" Screw
 - R** 4x Black rubber washer
 - S** 2x Stake hole cover
 - T** 2x 1/4-20 Lid screw (Taped to lid)
 - U** 2x Clamp angle shim*
 - V** 2x Expansion bolt*
 - W** 2x 1/4" x 5/8" Washer*
- * Use if no tie-down channel is present

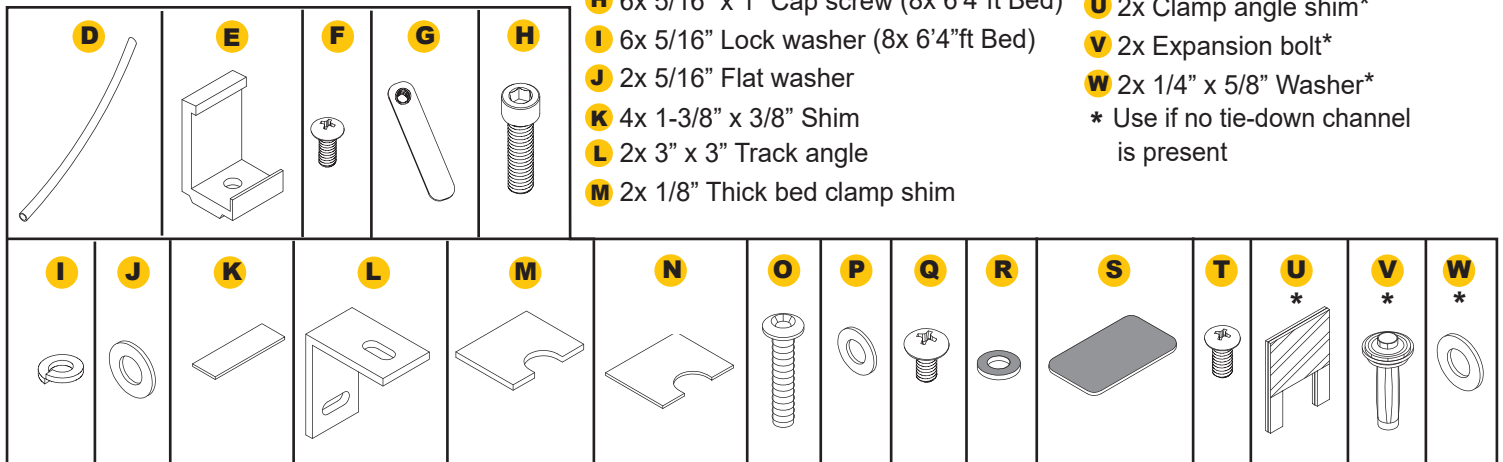

1A If there is No plastic bedliner proceed with step 1C. Remove the bedliner. 1. Using a tape measure with the measurements given, cut across the bulkhead (cab) from passenger to driver side using a jig saw to cut the liner part out. Discard cut parts. 2. Drill (5) 1/2" holes where indicated. Reinstall the bedliner.

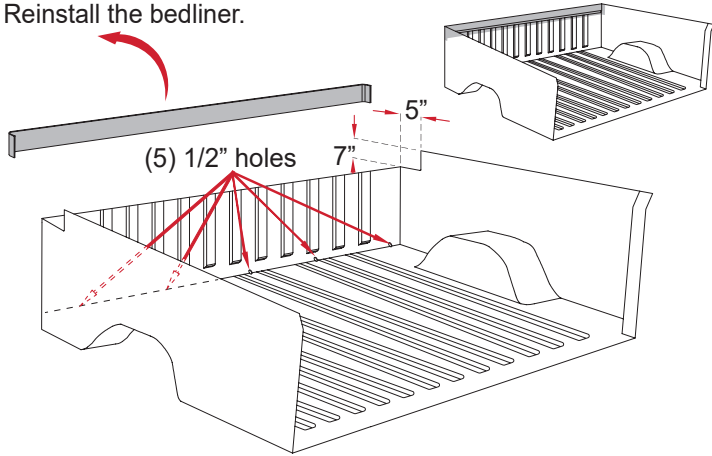

1B If there is NO plastic bedliner proceed with step 1C. Using a tape measure mark the tailgate protector (1) where to cut and then remove the tailgate to cut it. Discard cut parts. Re-install tailgate protector.

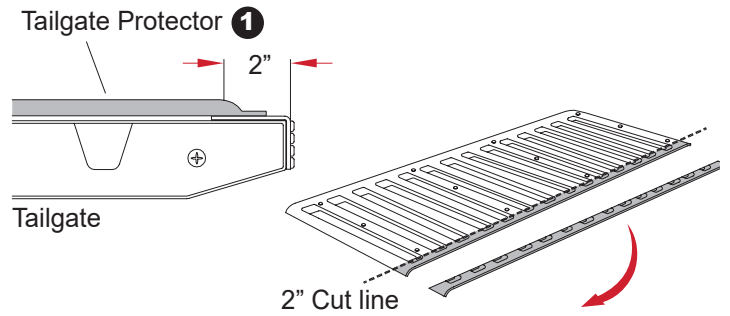

1C STAKE HOLE COVERS OPTIONAL - Use the stake hole covers (S) as needed on driver and passenger side toward tailgate.

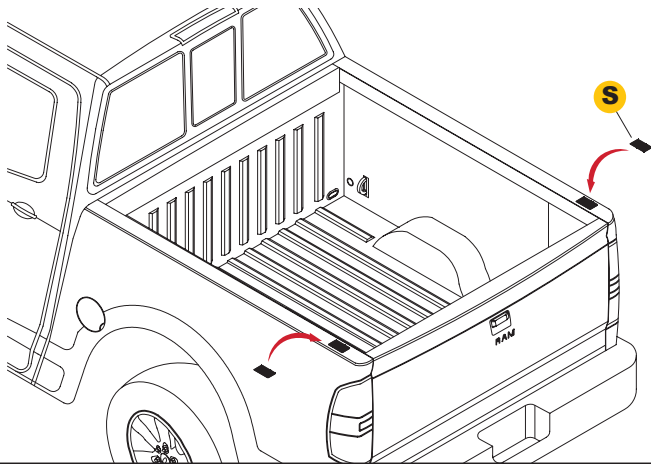

2 Center the housing (A) between the bed rails, and up against the bulkhead on driver and passenger side.

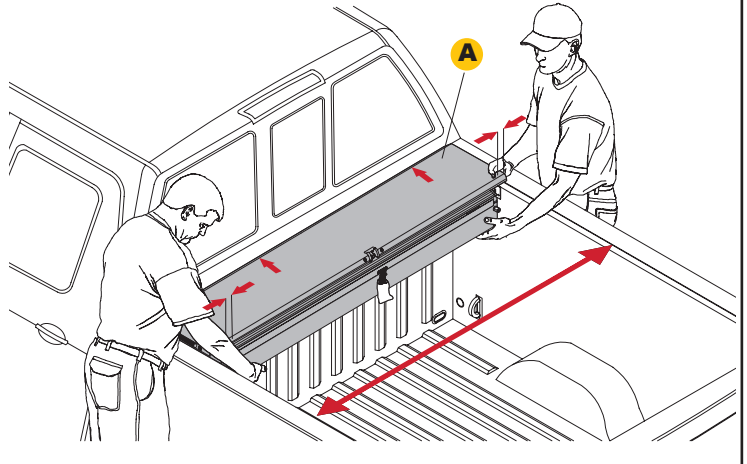

3 Remove lid from housing (A) by pushing toward cab (1) and up (2) on driver and passenger side.

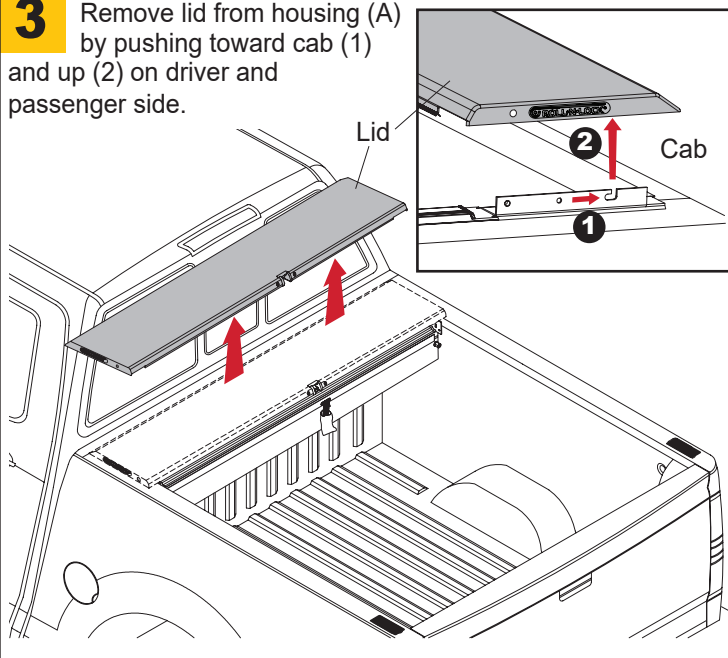

4A WITHOUT UTILITY RAIL - (1) Insert expansion bolt (V) into the top hex hole back towards the tailgate. (2) Use a 5/8" box wrench onto the holding sleeve and with a ratchet with 8mm socket tighten the bolt to secure clamping tines. (3) Back out screw leaving threaded insert. (4) Peel paper from back of shim and stick onto the back of the track angle (L). (5) Using the same screw with a supplied washer (W) and loosely install the track angle (L) as shown.

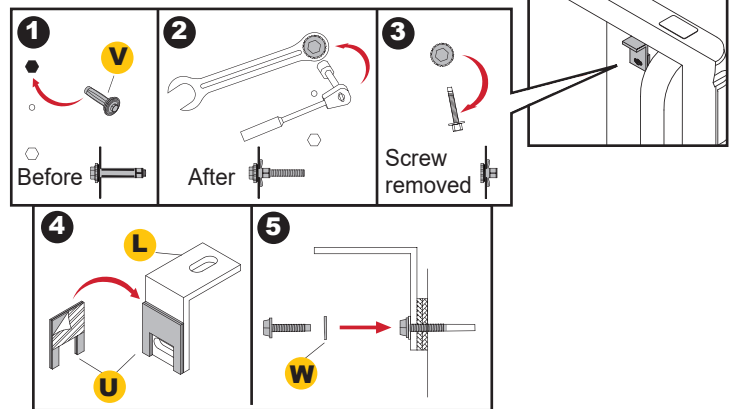

4B WITH UTILITY RAIL - (1) Remove top screw on bracket closest to tailgate and **discard**. (2) Use supplied 6mm x 40mm bolt (O) and M6 washer (P) and loosely attach supplied track angle (L). (3) Note slot orientation.

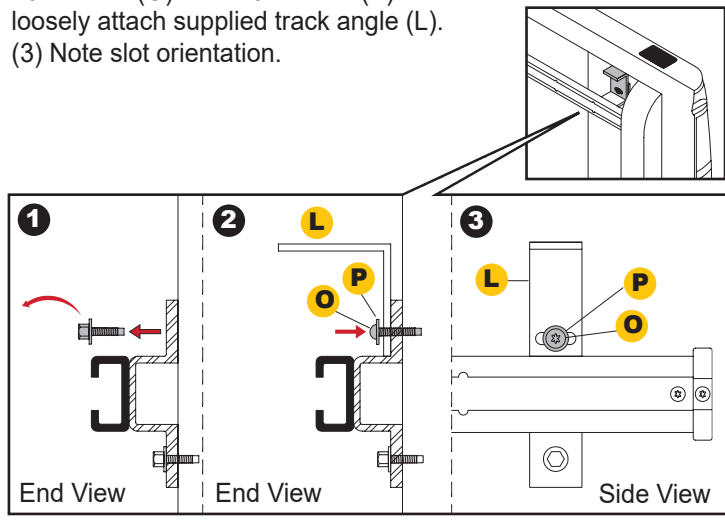

5 (1) Turn lock to 10 o'clock, attach tracks (B) onto housing stems. (2 & 3) Make sure the edge of the tracks butt up against housing on driver and passenger side.

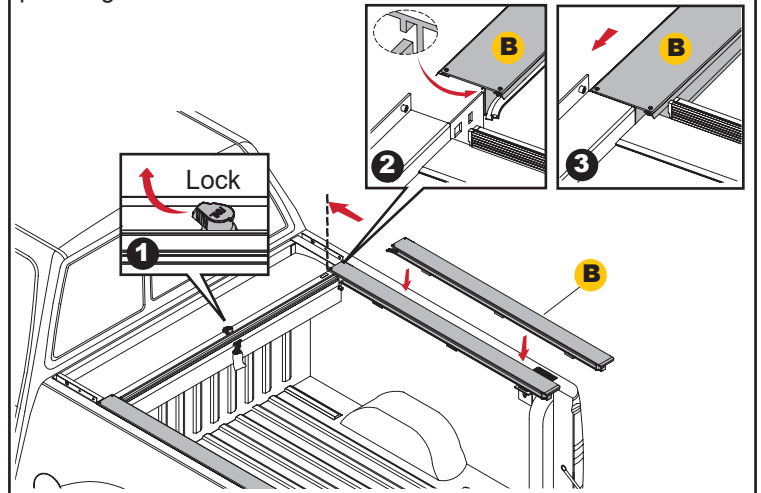

6 Secure tracks (B) to housing stem (1) on driver and passenger side using cargo nut (P) and #10-24 screw (Q) using a Phillips screwdriver (2) on driver and passenger side.

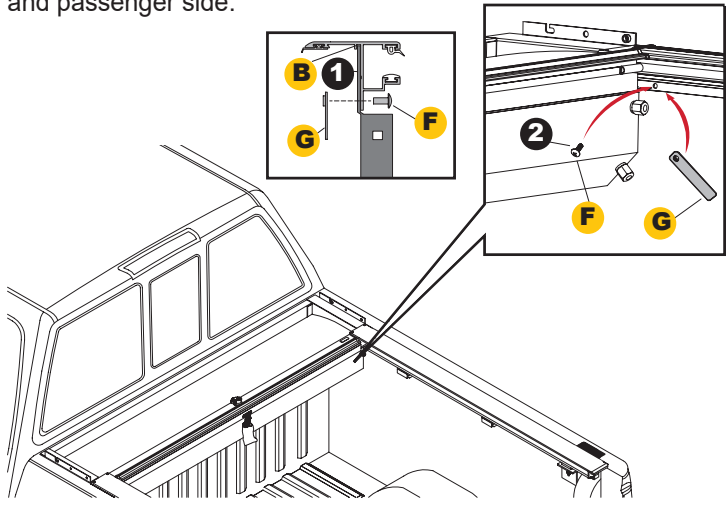

7 Loosely attach the 3"x3" track angle (L) to the pre-installed track clamps with 5/16" flat washer (J), 5/16" lock washer (I) and 5/16"x1" cap screw (H). Loosely attach bed clamps (E) to the pre-installed track clamps using 5/16" lock washer (I) and 5/16"x1" cap screw (H) on driver and passenger side.

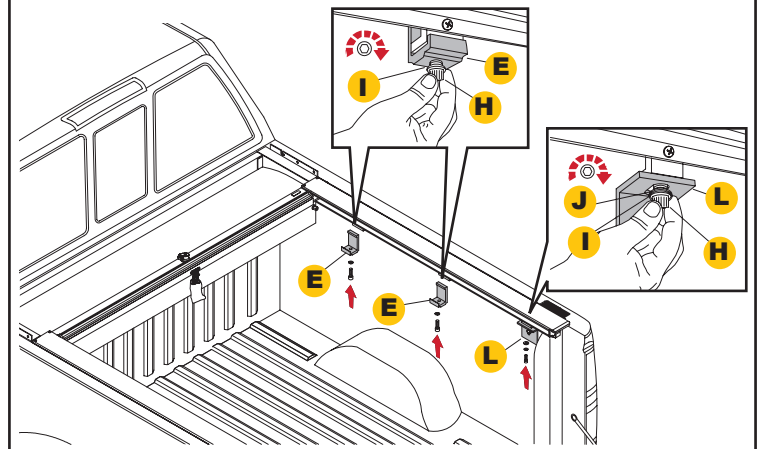

8 Close tailgate, shift the housing (A) back so the end of the tracks (B) are up against the tailgate on driver and passenger side.

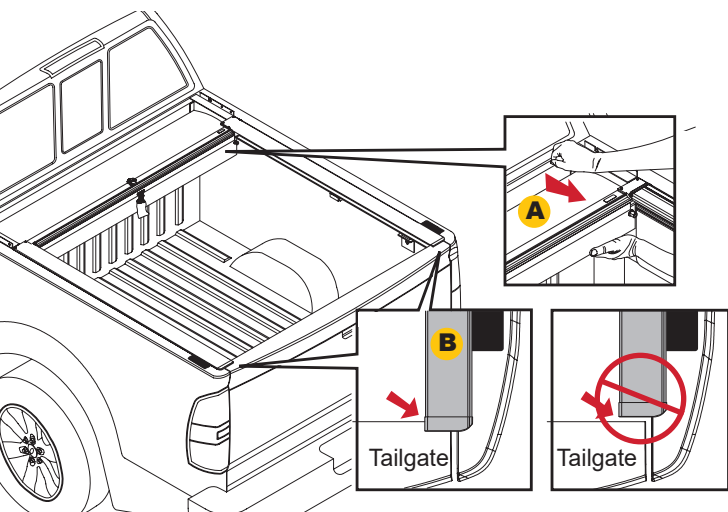

9 Important to check track to track inside dimension, otherwise the cover will not latch properly on driver and passenger side.

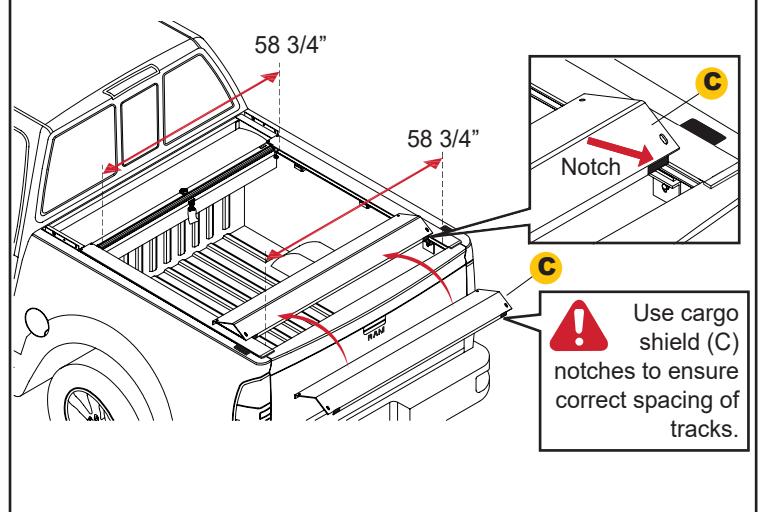

10A WITHOUT UTILITY RAILS - Use 1/8" thick bed clamp shim(s) (M) and/or 1/16" thick bed clamp shim(s) (N) as/if needed to level track to correct height and tighten fastener (1) using a 1/4" Allen wrench and fastener (2) using a ratchet with 8mm socket to tighten bolt to secure clamping lines on driver and passenger side.

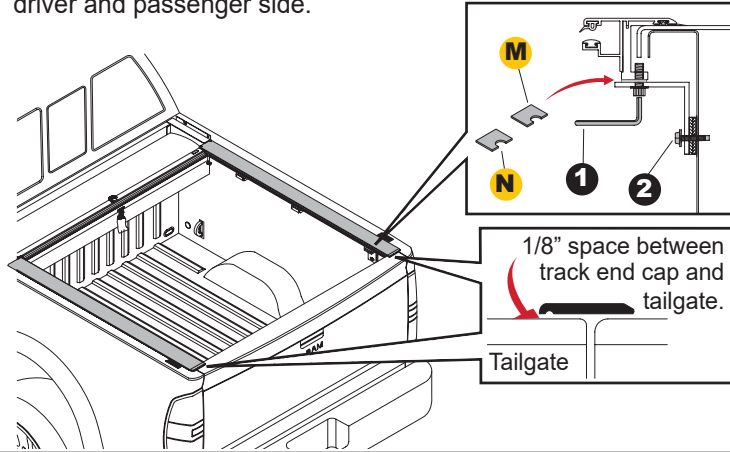

10B WITH UTILITY RAIL - Use 1/8" thick bed clamp shim(s) (M) and/or 1/16" thick bed clamp shim(s) (N) as/if needed to level track to correct height and tighten fastener (1) using a 1/4" Allen wrench and fastener (2) using a 4mm Allen wrench on driver and passenger side. Track should be in 90° position (3) on driver and passenger side. If not use 1-3/8"x3/8" shim(s) (K).

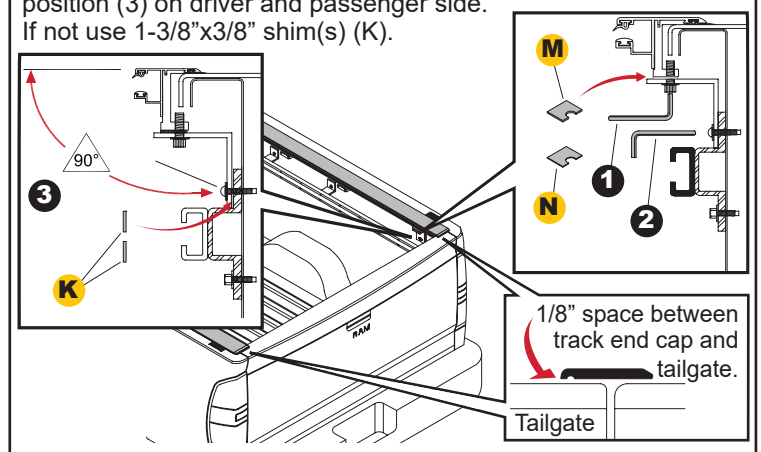

11 Tighten bed clamps (E) to the pre-installed track clamps using a 1/4" Allen wrench on driver and passenger side.
Note: When tight there may be a gap between the clamps, do not over-tighten.

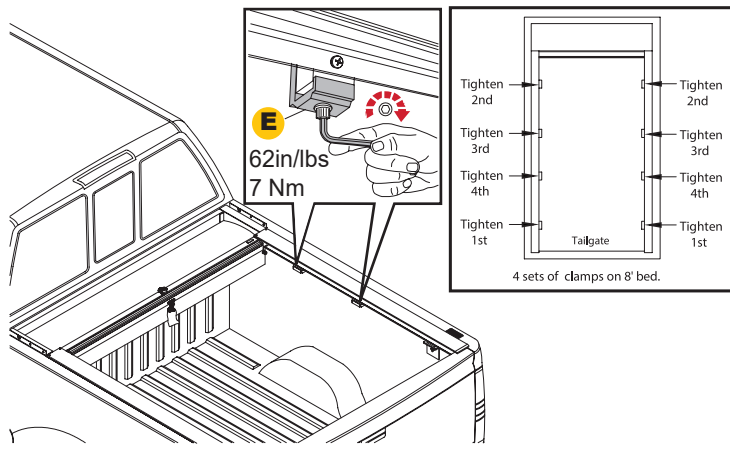

12 Turn lock to 7 o'clock (1), remove plastic wing nut (2) and using both hands pull cover back to tailgate.
(Discard plastic wing nut).

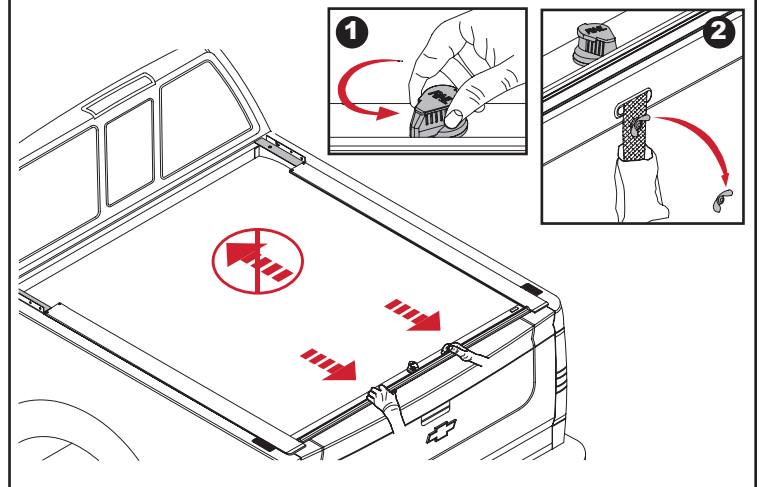

13 Replace lid on housing (A) by lining up the pin with the slot and pushing down (1) and toward tailgate (2) on driver and passenger side. Then install the 1/4" lid screws (T) with a Phillips screwdriver (3) on driver and passenger side.

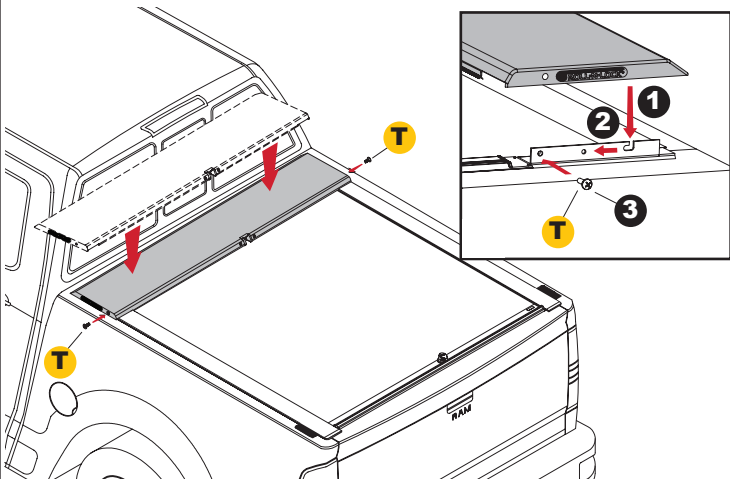

14 To open cover pull back on the handle, turn the lock (1 & 2) to 10 o'clock and let the cover retract into the housing (A) while holding onto the pull strap (3).

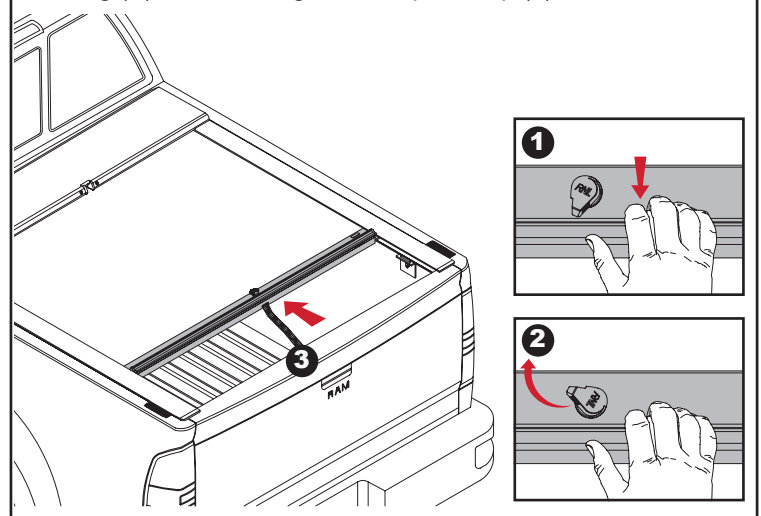

- 15** Attach cargo shield (C) with the slots at the bottom of the housing (A) using two black rubber washers (R) and two 1/4-20 x 3/8" screws (Q) on driver and passenger side.

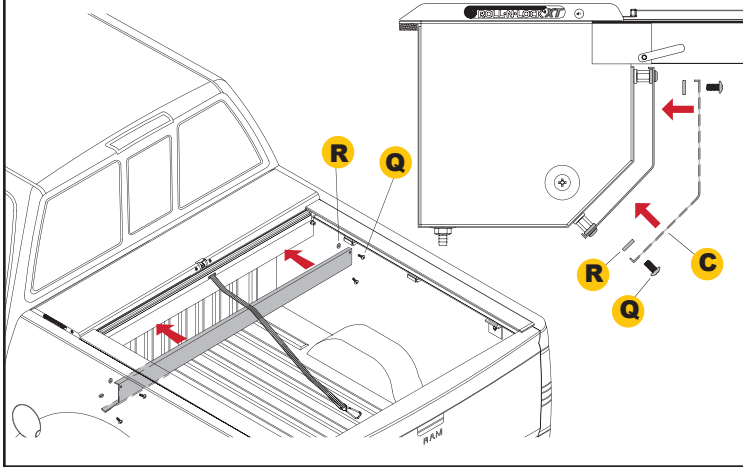

- 16** Take plug (1) out of hole in the side of the truck bed. Insert one end of the drain tube (D) through the hole and feed toward the ground and insert the other end onto the housing fitting on driver and passenger side.

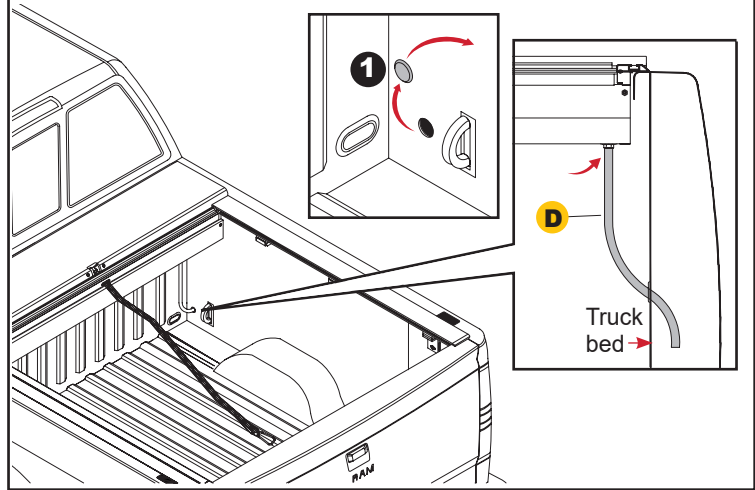

- 17** Attach pull strap to the trucks rear driver or passenger side rear tie-down towards tailgate.

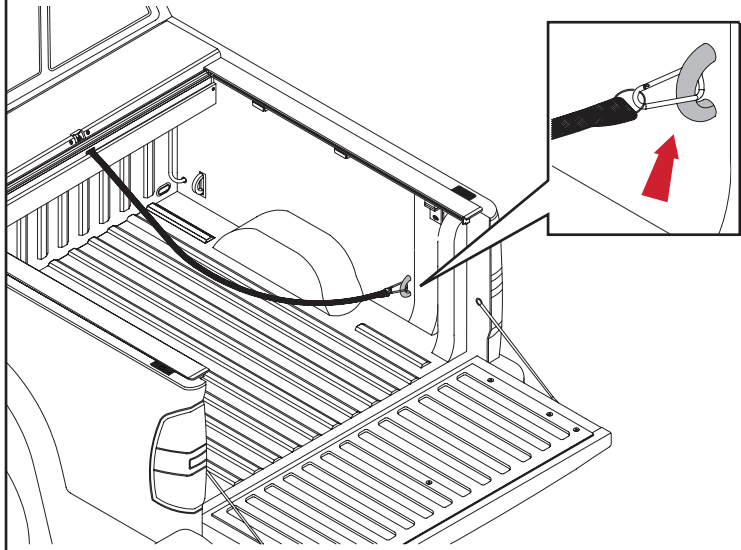

IMPORTANT NOTICE

This bed cover may retract to the full open position very quickly resulting in any objects placed on top of the bed cover to fall off the bed cover or become trapped inside of the bed cover carrier. Do not place ANY objects on top of the bed cover when attempting to close. Failure to follow the instruction may result in damage to your vehicle, belongings or bed cover. To avoid injury keep all body parts clear of the bed cover and carrier when opening.

LIMITED WARRANTY

WARRANTY COVERAGE

This truck bed cover is warranted against defects in materials or workmanship as follows. This warranty is void if the product has been damaged in an accident, or due to neglect, unforeseeable use, improper installation, improper servicing, or other cause not arising out of defects in material or workmanship.

The truck bed covers carries a limited warranty for three (3) years from the original date of purchase, subject to the terms below.

WARRANTY IS NOT TRANSFERABLE

The warranty is to the initial consumer purchasing the truck bed cover and it is not transferrable to a subsequent end user. Proof of purchase may be required to enforce these warranty rights.

WARRANTY CONDITIONS

Failure to follow these care and use instructions will void the warranty:

- Clean with mild automotive soap and water only. Do not use any strong chemicals or cleaners. Lubrication of the rails with silicone or petroleum-based products will void the warranty.
- Cargo must be secured at all points when the vehicle is in motion. Failure to adequately secure the cover or tether strap can result in damage and will void the warranty.
- Check all clamps and retention mechanisms for tightness after a week of driving following installation (or re-installation) of the cover and periodically thereafter.
- Before opening, the cover must be free of all foreign materials including snow and ice.
- Do NOT tow your vehicle from the rear with the cover on your vehicle. If towing from the rear is required, the cover MUST be removed from the vehicle and properly stored.

WARRANTY PERFORMANCE

If all warranty conditions are met, a defective truck bed cover or hardware component will either be repaired or replaced (at our option). We reserve the right, for any warranty, to substitute a newer model or bed cover having a similar form and function, to offer a warranty discount on an entire replacement system, and/or provide remedies other than those mentioned in this document.

WARRANTY RETURN

A Return Material Authorization number must be obtained from our Customer Service Department prior to returning any product. We may require the original item to be returned postage prepaid for final determination. Shipping charges will apply for any repair or replacement. Other than postage or shipping charges, no charge will be made for repair or replacement under this warranty.

This warranty gives you specific legal rights. As a consumer, you may also have additional rights and remedies under the laws of your state.

Register online at <https://realtruck.com/rollnlock-warranty>.

**REGISTER
YOUR
WARRANTY
ONLINE**



COVER CARE AND MAINTENANCE

Vinyl Tops

Clean with mild automotive soap and water only. Do NOT use any strong chemicals or cleaners. Do NOT use conditioners that contain silicone or petroleum. We recommend using 303 Aerospace Protectant® to prolong the life of the vinyl.

Hard Tops

Clean with mild automotive soap and water only. Do NOT use any strong chemicals or cleaners. Use of wax or polish is not recommended.

Maintenance

It is recommended that you periodically check that the cover is securely attached to your truck bed. Inspect the clamps and front mounting bolts to ensure they were properly installed and have not come loose or knocked out of adjustment during operation. Covers that are used with high frequency or that are subject to the vibrations and impact from rough roadways can cause the cover to require adjustment.

IMPORTANT: NEVER spray any lubricant into the tracks. **THIS WILL VOID YOUR WARRANTY.** Lubricants, especially silicone or petroleum-based, will attract dirt and debris which will lead to slow operation and will degrade the gaskets over time. If the tracks feel a little 'sticky', you may spray some 303 Aerospace Protectant® inside the track and wipe with a clean rag to remove any dirt or debris that has built up.

Housing Drains

To ensure proper drainage, it is recommended that the canister housing be checked and cleared of any leaves, twigs or other debris that may obstruct the drain tubes.

To remove the lid, first, make sure the Roll-N-Lock cover is fully closed and securely latched at the tailgate. Remove the Phillips head screw on each side of the lid and slide the lid slightly forward toward the cab to disengage the set pins. Once free, the lid can be lifted and removed from the canister. **DO NOT ALLOW THE COVER TO RETRACT WITH THE LID REMOVED.** This could allow the cover to retract too far into the canister causing damage to the cover.

USE

Opening and Using the Cover

Grasp the handle with one hand and pull towards the tailgate to relieve pressure on the latches. At the same time, turn the tear-drop lock from the 7 o'clock latched position to the 10 o'clock unlatched position. Release the handle and the cover should begin to retract. The cover may require a slight push to get it started retracting. The tether strap can be used to control the speed of the cover as it retracts. Allow the cover to retract fully into the lid and this will reset the tear-drop lock to the 7 o'clock position.

Closing and Locking the Cover

Using the tether strap, gently pull the cover toward the tailgate. Once the cover handle is within reach, grasp with both hands, and pull the cover closed until it latches into place making sure that the tear-drop lock is pointed at the 7 o'clock position. Secure the tether strap inside the truck bed when latching. Forcing or slamming the cover back may damage the truck or cover. Never close the cover with the tear-drop lock pointed at 10 o'clock as the latches will not engage properly. **Always close the cover body with the tear-drop lock pointed at 7 o'clock.** Failure to close the cover body correctly will result in the unit not latching.

SAFETY INSTRUCTIONS

- DO NOT place objects on or against the cover or framework.
- DO NOT tie cargo to truck bed cover framework.
- DO NOT operate the vehicle with objects on top of the cover body.
- NEVER allow children or pets to occupy the truck bed while the cover is closed.
- The cover is not airtight. Special care is required to keep cargo clean and dry.
- Bed covers won't prevent theft of contents inside the truck box.

TROUBLESHOOTING TIPS

The cover is slow to retract.

- Spray 303® on a rag and wipe the top gasket in the track.

The cover does not latch.

- Check track to track measurement.

Track tips up or down.

- Use shim(s) behind bracket to level track.

The cover does not reach the tailgate.

- Make sure tracks are back against the tailgate.