

**2WD RANGER 82-97  
CLASS I  
INSTALLATION INSTRUCTIONS**



---

Before beginning the installation, read these instructions and the enclosed driver's "WARNING NOTICE" thoroughly and completely. Also affix the "WARNING" decal in passenger compartment in clear view of all occupants. If any of these items are missing from this instruction packet, do not proceed with installation, but call SKYJACKER® to obtain needed items. If you have any questions or reservations about installing this lift kit, call SKYJACKER® at 318-388-0816 for Technical Assistance and Customer Service departments.

Due to the inconsistency of vehicles when manufactured and the various options available, the amount of actual lift gained by this lift kit can vary as much as ½".

---

**BEGIN INSTALLATION:**

1. Make sure to park the vehicle on a level concrete surface. Many times a vehicle is un-level from side-to-side (even when brand new), but usually not noticed until modifying the suspension with a lift kit which makes it more noticeable. If the vehicle is un-level beforehand it will also after the lift is installed. Using a measuring tape, measure the front and rear (both sides) from the ground up to the center of the fender opening above each axle. Record below for future reference.

**BEFORE**

Driver side, Front: \_\_\_\_\_ Rear: \_\_\_\_\_ Passenger side, Front: \_\_\_\_\_ Rear: \_\_\_\_\_

**AFTER**

Driver side, Front: \_\_\_\_\_ Rear: \_\_\_\_\_ Passenger side, Front: \_\_\_\_\_ Rear: \_\_\_\_\_

**FRONT INSTALLATION:**

2. Raise front of vehicle and support securely with jack stands under the frame behind front springs and block the rear wheels. Remove the tires and shocks. Now remove the drag link assembly from the pitman arm and lower assembly down. Loosen the brackets that hold the anti-sway bar (stabilizer bar) to the frame, but do not remove.
3. With a floor jack under the radius arm center cross member and light pressure applied, remove the 2 bolts and 2 rivets from radius arm at frame on each side of cross member. Block up cross member and remove jack.
4. Place one floor jack under differential on left axle housing, and another floor jack under right axle housing between coil spring and center hinge bracket. With light pressure applied from the jacks, remove the shock, and then remove the lower retaining nut and washer at the bottom of coil spring. Lower jack down and remove coil spring. Coil will come out at top by twisting it. It may also be necessary to loosen the 2 bolts on bottom shock bracket. Repeat on other side.
5. Unbolt the center hinge bracket from the left (front) axle beam. Lower the axle beam down, remove the upper bolts from bracket and discard bracket (save the original bolts).

6. Remove the axle beam bolt from the right hinge bracket. Remove the two rivets from bottom of center hinge bracket so that axle beam can be lowered down. **(NOTE: This bracket is not removed from cross member. The new bracket will bolt to the bottom of this existing bracket.)**
7. To install new left (front) axle beam bracket, the original bolts will be reused in original locations. Start all the bolts first, then tighten all of them. Swing up axle beam, install original hinge bolt and tighten. Be sure all bolts are tight. See Illustration #1.
8. To install new right axle beam bracket, bolt it to the existing racket using the 7/16" x 1 1/2" bolts and 9/16" x 1 1/2" Fine Thread Bolt included (the bottom hole uses the 1/2" x 1 1/2" bolt also included.) See Illustration #2.
9. Install new radius arm brackets, and bolt original brackets to the new ones (7/16" x 1 1/2"). Use one washer under each bolt head and one against the nut. Tighten all bolts.
10. With jack under coil spring, install the new spring and shock, and tighten the 2 bolts on bottom shock bracket. Repeat on other side. Be sure all nuts and bolts are tight. Install tires and lower vehicle to the ground.
11. Retighten the anti-sway bar bolts (torque to original specs). Be sure the rubber bushings are not worn since this is critical to the handling characteristics of the vehicle.

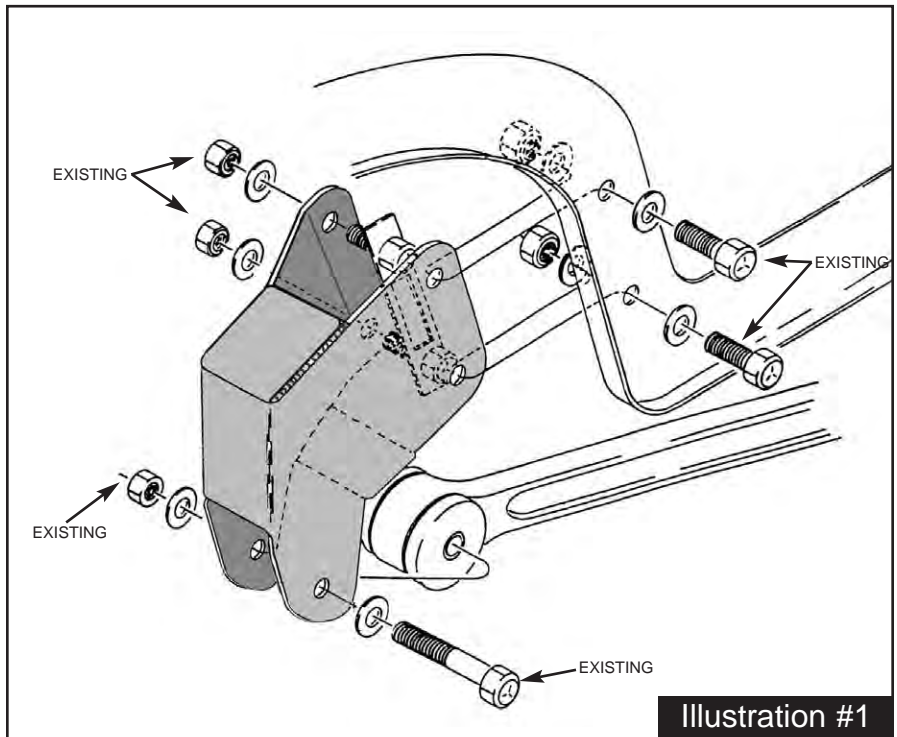

Illustration #1

Refer to Pitman Arm Instructions at this time.

### **REAR INSTALLATION:**

12. Raise rear and support securely with jack stands and block the front wheels. Remove the tires, shocks, and u-bolts.

**(CAUTION: The rear axle will now be free to move, so support securely on floor jack.)**

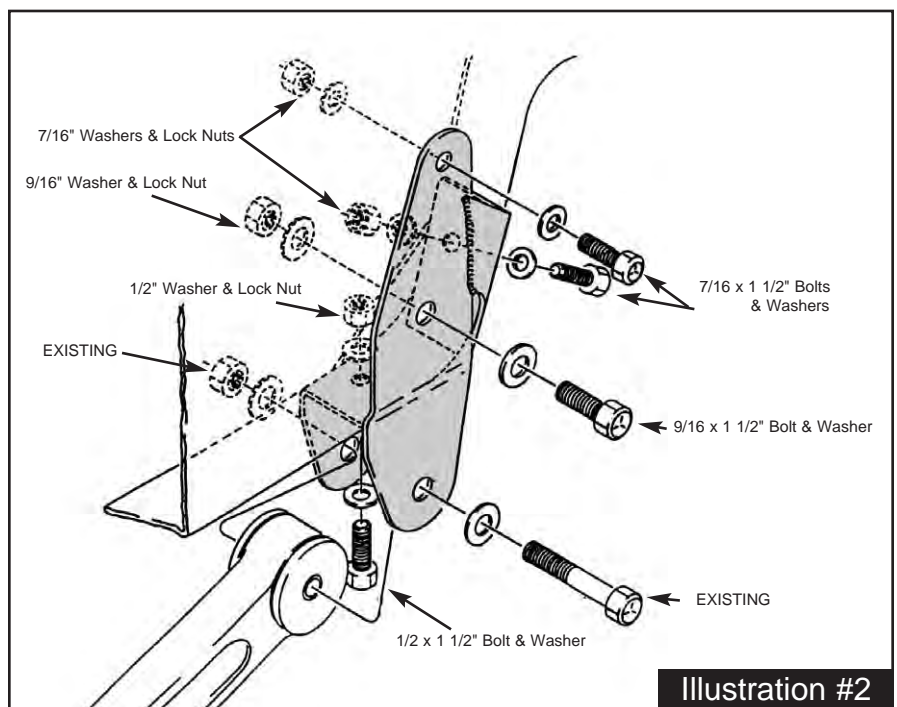

Illustration #2

"SYSTEMS" with rear springs, continue with Step #12, otherwise go to Step #13.

13. **NEW SPRING INSTALLATION:** Remove the original springs from vehicle. Install new springs with long end of springs towards rear bumper. (NOTE: on springs with a bottom degree shim, thick end of shim must also be towards rear bumper.)

14. **BLOCK INSTALLATION:** Place new block (tallest end toward rear bumper) between rear spring and axle housing. Using floor jack, raise axle up being sure that block pins are aligned in axle housing and that spring bolt is aligned in block.

15. Install and tighten new u-bolts evenly. Install rear shock absorbers, tires, remove jack stands and lower vehicle down. Rear installation is complete.

**NOTE:** After driving the first 50 miles, re-torque **ALL** nuts, bolts and **ESPECIALLY U-BOLTS**, torque again for another 100 miles and then check periodically thereafter.

### **TROUBLE SHOOTING:**

Upon completion of installing the entire lift (front and rear) if the vehicle appears to sit un-level go to step 1 and record the AFTER measurements to verify the amount of lift obtained at each point. If the vehicle does sit un-level and **it did not sit un-level in step 1**, the following can be checked:

1. Be sure all of the polyurethane bushings were greased well so that they will not restrict the spring's movement.
2. Check the condition of the shackle bushings in the frame (if not replaced with new ones) to be sure they are not worn, and if so, replace them with new polyurethane bushings.
3. Check the body bushings between the frame and the body to be sure they are not showing wear. If so, SKYJACKER® offers replacement polyurethane kits.
4. In order to be sure that the bushings are not restricting the spring from being at the correct ride height, loosen (do not remove) the spring eye bolts. Then stand on the bumpers and bounce the vehicle up and down vigorously to free up the bushings and then retighten spring eye bolts.

### **NOTES:**

To help correct steering angle on lifted vehicles, drop pitman arm #FA400 is recommended. (Power Steering Only)

All Ford Independent front suspensions (IFS) require front end alignment after suspension changes are made. Your local front end shop can do this. Toe-in and camber adjustment is required. If needed, camber bushings are available direct from Skyjacker®:

Vehicle:	Part #:	Description:
Ranger 83-88	1043H	0 - 2° Degree adjustable camber/caster shim.
Ranger 89-97	1029H	0 - 2° Degree adjustable camber/caster shim.

Be sure and have front end alignment check periodically by a professional for your safety and longer tire life.

### **NOTICE:**

Re-torque **ALL** nuts, bolts, and especially the u-bolts after the first 50 miles, again after another 100 miles. Check periodically thereafter. Check drive shafts to be sure there is proper length. Check brake line length; it may be necessary to re-route original lines or replace with new longer SKYJACKER® replacement stainless steel lines.

*SEAT BELTS SAVE LIVES. PLEASE WEAR YOUR SEAT BELT.*