



www.skyjacker.com

**REQUIRED TOOL LIST:**

- Safety Glasses
- Metric / Standard Wrenches & Sockets
- Floor Jack
- Jack Stands
- Measuring Tape
- Torque Wrench
- Torsion Bar Tool

**2011 Chevy / GM 2500HD 4WD  
Dual Steering Stabilizer  
Installation Instructions  
Part # 7211**

Before beginning the installation, thoroughly & completely read these instructions & the enclosed driver's WARNING NOTICE. Affix the WARNING decal in the passenger compartment in clear view of all occupants. Please refer to the Parts List to insure that all parts & hardware are received prior to the disassembly of the vehicle. If any parts are found to be missing, contact SKYJACKER® Customer Service at 318-388-0816 to obtain the needed items. If you have any questions or reservations about installing this product, call SKYJACKER® Technical Assistance at 318-388-0816.

**NOTE:** This steering stabilizer kit is designed for the 2011 GM 2500HD 4WD with a minimum of 4" of lift. **Do not** attempt to install this steering stabilizer kit on a vehicle with less than 4" of lift.

**Kit Box Breakdown:**

**Part #: 7211**

ITEM#	DESCRIPTION	QTY
7202WS	WHITE STEERING DAMPER	2
HB-7211	HDWR BAG: 7211	1
HSS	HYDRO SHOCK DECAL	2
I-7211	INST SHEET: 7211	1

**Hardware Bag Breakdown:**

**HB-7211                      HARDWARE BAG**

ITEM#	DESCRIPTION	QTY
7211DS-1	DRIVER BRKT FOR 7211 STAB	1
7211MB-1	MAIN BRKT FOR 7211 STAB	1
7211PS-1	PASS BRKT FOR 7211 STAB	1
HOURGLASS 5/8	HOURGLASS 5/8 SHOCK BUSHING	4
140629	EB6 STUD BAG - P932/140629	4
18MMFW	5/8"-A325 FLAT WASHER,PLAIN	2
516X138X2316U	5/16X1 3/8X 2 3/16 U-BLT RD	2
516CTN	5/16-18 COARSE N/I LOCK NUT	4
516SAEW	5/16 SAE WASHER	4
I-7211 6-11		

## Installation:

1. Park the vehicle on a level concrete or asphalt surface with the front tires / wheels pointing straight forward.
2. Set the emergency brake & block the rear tires / wheels.
3. If equipped, remove the OEM steering stabilizer from the OEM mount on the frame & OEM center link.
4. Place a floor jack under the lower control arm's front cross member & raise the vehicle. Place jack stands under the frame rails, behind the front wheel wells & lower the frame of the vehicle onto the jack stands.



Photo # 1



Photo # 2



Photo # 3



Photo # 4

**WARNING:** Be extremely careful when loading or unloading the torsion bars; there is a tremendous amount of stored energy (load pressure) in the torsion bars. Keep your hands & body clear of the adjuster arm assembly & puller tool in case anything slips or breaks.

**NOTE:** A special PULLER TOOL (Kent - Moore Part # CH-48809 is required for the SAFE REMOVAL / INSTALLATION of the torsion bars. This special puller can be purchased from a GM dealer or auto parts store.

5. Locate the torsion bar adjuster bolt on the bottom of the torsion bar cross member, measure & record the length of the torsion bar adjusting bolt that is exposed. Apply a small amount of lubricating grease to the puller threads & the puller shaft-to-adjuster arm contact point. Position the puller & load the adjuster arm until the adjuster nut can be removed from the torsion bar cross member using a 21mm socket. (See Photo # 1) Repeat this process on the opposite side.
6. Install the four new Skyjacker studs to the driver side, center, & passenger side brackets using a 3/4" socket & adjustable pliers. (See Photo # 2, 4, & 5)
7. Remove the upper front cross member bolt on the passenger side of the vehicle. Install the supplied 18mm washer between the OEM cross member & the new Skyjacker passenger side bracket. Install the upper front cross member bolt (**With the hex head of the bolt to the new bracket**) thru the new bracket, 18mm washer, & OEM cross member using a 1 1/16" socket. (See Photo # 2)
8. Bend the OEM stabilizer mounting bracket tabs upward using a hammer & punch. (See Photo # 3)
9. Remove the upper front cross member bolt on the driver side of the vehicle. Install the supplied 18mm washer between the OEM cross member & the new Skyjacker driver side bracket. Install the upper front cross member bolt (**With the hex head of the bolt to the new bracket**) thru the new bracket, 18mm washer, & OEM cross member using a 1 1/16" socket. (See Photo # 4)

10. Measure from the base of the inner tie rod  $12\frac{9}{32}$ " & mount the new Skyjacker center bracket parallel with the angle of the OEM center link steering stabilizer mounting hole using the  $\frac{5}{16}$ " x  $1\frac{3}{8}$ " x  $2\frac{3}{16}$ " u-bolts, washers, nuts, &  $\frac{1}{2}$ " socket. (See Photo # 5 & 6)

11. Install the  $\frac{5}{8}$ " hourglass bushings into each end of the new Skyjacker steering stabilizers & mount with the shaft end of the new steering stabilizers towards the inside using the washers, nuts, &  $\frac{3}{4}$ " socket. (See Photo # 7)

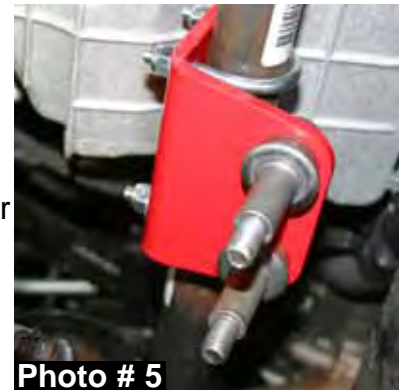

Photo # 5

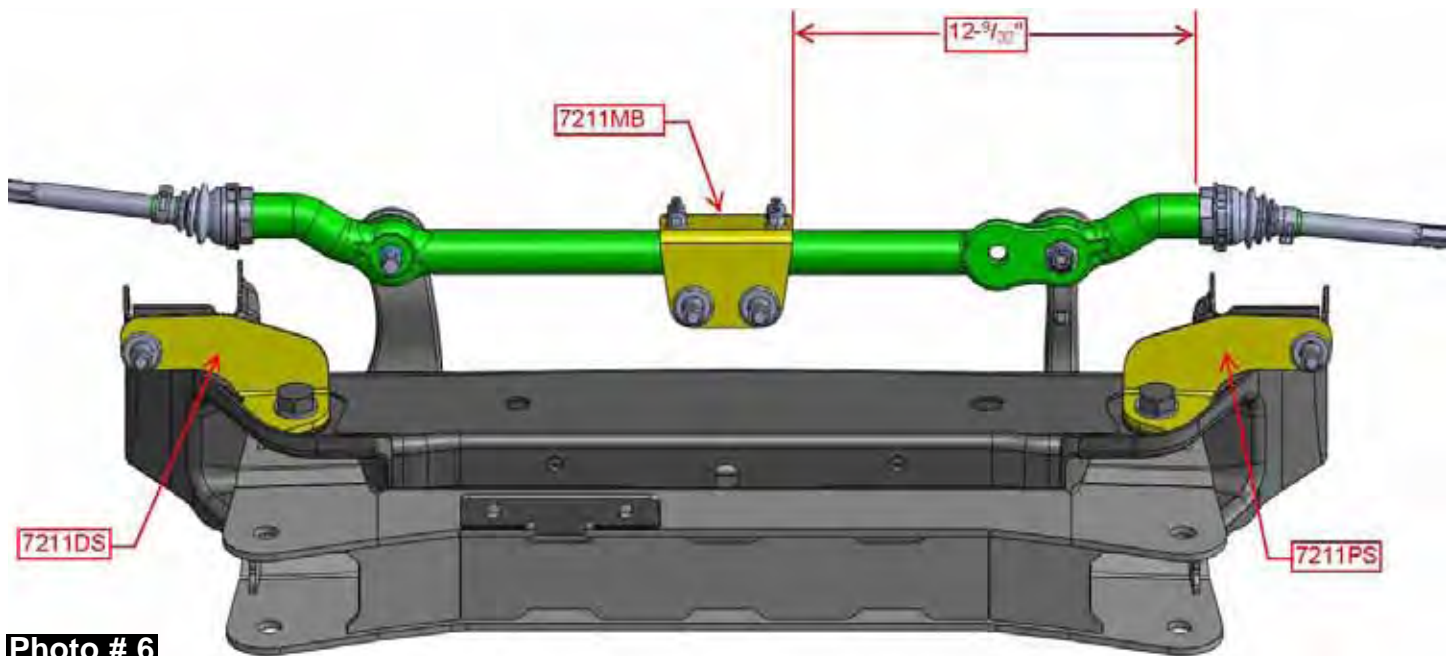

Photo # 6

12. Position the torsion bar puller & load the adjuster arm until the adjuster nut can be installed to the torsion bar cross member using a 21mm socket. (See Photo # 1) Repeat this process on the opposite side. **Note:** Be sure to install the adjuster bolts to the same length as the OEM when removed in Step # 5.

13. Using a floor jack, remove the jack stands from under the frame rails & lower the vehicle to the ground.

#### **Final Notes:**

- Cycle the steering of the vehicle left to right & check all parts for adequate clearance.
- After the first 100 miles, check all of the hardware for the proper torque.



Photo # 7

**Seat Belts Save Lives, Please Wear Your Seat Belt.**



## *Jesus Christ Died For You.*

John 3:16

For God so loved the world that He gave His only Son, so that everyone who believes in Him should not perish, but have everlasting life.  
Romans 3:23

For all have sinned; all fall short of God's glorious standard.  
Ephesians 2:8

God saved you by his special favor when you believed. And you can't take credit for this; it is a gift from God.  
Psalms 18:2

The Lord is my Rock, my fortress, and my savior; my God is my Rock, in whom I find protection. He is my shield, the strength of my salvation, and my stronghold.  
Romans 10:9-10

That if you shall confess with thy mouth the Lord Jesus, and shall believe in your heart that God hath raised him from the dead, you shall be saved. For with the heart man believeth unto righteousness; and with the mouth confession is made unto salvation.

Pray This Simple Prayer:

God, I come to You admitting I have sinned against You and I need you to take control of my life. The Bible says anyone who calls on the name of the Lord will be saved. I am calling on You, Jesus. I ask that You come live in my heart and be the Lord over my life today. I do believe You died on the cross for me and came back to life to give me life! Thank You, Lord Jesus for a new life in You!

Now, go and tell somebody about your new life in Jesus, get a Bible, begin to read it, and go to a Bible believing church.

If you would like someone to pray with you, call Kenneth Copeland Ministries anytime at 800-600-7395.

To listen to commercial free Christian radio on the web, go to [www.887fm.org](http://www.887fm.org)

## *Jesús murió por ti.*

Juan 3:16

"Porque tanto amó Dios al mundo, que dio a su Hijo unigénito, para que todo el que cree en él no se pierda, sino que tenga vida eterna."  
Romanos 3:23

"Pues todos han pecado y están privados de la gloria de Dios."  
Efesios 2:8

"Porque por gracia ustedes han sido salvados mediante la fe; esto no procede de ustedes, sino que es el regalo de Dios."  
Salmos 18:2

"El Señor es mi roca, mi amparo, mi libertador; es mi Dios, el peñasco en que me refugio. Es mi escudo, el poder que me salva, ¡mi más alto escondite!"  
Romanos 10:9-10

"9 Que si confi esas con tu boca que Jesús es el Señor, y crees en tu corazón que Dios lo levantó de entre los muertos, serás salvo. 10 Porque con el corazón se cree para ser justifi cado, pero con la boca se confi esa para ser salvo."

Ahora dí esta simple oración:

Dios, vengo a Ti y admito que he pecado contra Ti, necesito que tomes el control de mi vida. La Biblia dice que todo aquel que invoca el nombre del Señor escapará con vida. En este momento yo clamo ante Ti, Jesús; te pido que vengas a vivir en mi corazón y que tomes el control de mi vida. ¡Yo creo que tu moriste en la cruz y resucitaste para darme vida! ¡Gracias Señor Jesús, por una nueva vida que tengo en Ti! Amen.

Ahora ve y dile a alguien sobre la nueva vida que tienes en Cristo. Compra una Biblia y empieza a leerla. Busca una Iglesia que cree en la Biblia y hazte parte de esa Iglesia.

Si te gustaría orar con alguien, puedes llamar a este número 800-600-7395

Puedes ir a este sitio de Internet para escuchar música Cristiana sin anuncios, [www.887fm.org](http://www.887fm.org)

**Check out our favorite ministries at:**

**[www.innministries.org](http://www.innministries.org)**

**[www.familychurch.org](http://www.familychurch.org)**

**[www.kcm.org](http://www.kcm.org)**

