



www.skyjacker.com
REQUIRED TOOL LIST:

2007- 2013 GM 1500 Pick-Up / SUV 4WD 6" Suspension Lift Installation Instructions

- * Safety Glasses
- * Metric / Standard Wrenches & Sockets
- * Allen Wrenches
- * Assorted Drill Bits
- * Floor Jack
- * Jack Stands
- * Measuring Tape
- * Torque Wrench
- * Reciprocating Saw
- * Grinder



Before beginning the installation, thoroughly & completely read these instructions & the enclosed driver's WARNING NOTICE. Affix the WARNING decal in the passenger compartment in clear view of all occupants. Please refer to the Parts List to insure that all parts & hardware are received prior to the disassembly of the vehicle. If any parts or hardware are found to be missing, contact SKYJACKER® Customer Service at 318-388-0816 to obtain the needed items. If you have any questions or reservations about installing this lift kit, contact SKYJACKER® Technical Assistance at 318-388-0816.

Make sure you park the vehicle on a level concrete or asphalt surface. Many times a vehicle is not level (side-to-side) from the factory & is usually not noticed until a lift kit has been installed, which makes the difference more visible. Using a measuring tape, measure the front & rear (both sides) from the ground up to the center of the fender opening above the axle. Record this information below for future reference.

Driver Side Front: _____ Passenger Side Front: _____

Driver Side Rear: _____ Passenger Side Rear: _____

IMPORTANT NOTES:

- If larger tires (10% more than the stock diameter) are installed, speedometer recalibration will be necessary. Contact your local GM dealer or an authorized dealer for details.
- After installation, a qualified alignment facility is required to align the vehicle to the OEM specifications.

Component Box Breakdown:

Part #: C7661A

| Item # | Description | Qty |
|------------|---------------------------|-----|
| C766L | 6" GM 1500, DRV KNUCKLE | 1 |
| C766R | 6" GM 1500, PASS KNUCKLE | 1 |
| C7662FCM-B | 6" GM 1500 FRONT X-MEMBER | 1 |

| Item # | Description | Qty |
|--------------|----------------------------|-----|
| C7662RCM-B | 6" GM 1500 REAR X-MEMBER | 1 |
| C766SKD-S | 6" GM 1500 DIFF SKID PLATE | 1 |
| H-BOX C7661A | HDWR BOX: C7661A COMP BOX | 1 |

Hardware Box Breakdown:

Part # H-BOX C7661A

| Item # | Description | Qty |
|-----------|-----------------------------|-----|
| C766CVS-S | 6" GM FRONT CV SPACER | 2 |
| C766FDS-D | 6" GM 1500 DRV DIFF BRACKET | 1 |
| C766FDS-P | 6" GM 1500 PAS DIFF BRACKET | 1 |
| C766SBL-S | GM OE STYLE SWAY BAR LINK | 2 |
| C736SBL | GM SWAY BAR LOW SPACER | 2 |
| C766TA-NG | 6" GM TORQUE ARM LINK | 1 |
| C766RBB-S | 6" GM REAR BRAKE LINE EXT | 1 |

| Item # | Description | Qty |
|--------------|----------------------------|-----|
| FBL83 | GM 1500 FRONT BRAKE LINES | 1 |
| HB-C7662-CM | HDWR BAG: C7662 X-MEMBER | 1 |
| HB-C766-CVS | HDWR BAG: C766 CV SPACER | 1 |
| HB-C766-DS | HDWR BAG: C766 DIFF BRKTS | 1 |
| HB-C766-BL | HDWR BG: ABS/BRK/SWAY BRKT | 1 |
| HB-C766TA-NG | HDWR BG: C766TA-NG TOR ARM | 1 |
| HB-SKD | HDWR BAG: C766 SKID PLATE | 1 |

Hardware Bag Breakdown:

Part # HB-C7662-CM

| Item # | Description | Qty |
|-----------|------------------------------|-----|
| 58X412FTB | 5/8 X 4 1/2 FINE THREAD BOLT | 2 |
| 58X512FTB | 5/8 X 5 1/2 FINE THREAD BOLT | 2 |

| Item # | Description | Qty |
|--------|--------------------------|-----|
| 58FTN | 5/8 FINE THREAD LOCK NUT | 4 |
| 58SAEW | 5/8 SAE WASHER | 8 |

Part # HB-C766-CVS

| Item # | Description | Qty |
|------------|-----------------------------|-----|
| 10MMX70MMB | 10MM X 70MM METRIC BOLT | 12 |
| LT100 | NUTS N' BOLTS 427 1 ML TUBE | 1 |

| Item # | Description | Qty |
|-----------|-------------------------|-----|
| 5MMX12SHB | 5MM X 12MM KNUCKLE BOLT | 2 |

Part # HB-C766-DS

| Item # | Description | Qty |
|----------|-----------------------------|-----|
| 12X2FTB | 1/2 X 2 FINE THREAD BOLT | 2 |
| 12SAEW | 1/2 SAE WASHER | 2 |
| 12FTN | 1/2 FINE THREAD LOCK NUT | 2 |
| 916X2CTB | 9/16 X 2 COARSE THREAD BOLT | 2 |

| Item # | Description | Qty |
|----------|---------------------------|-----|
| 916SAEW | 9/16 SAE WASHER | 4 |
| 916CTN | 9/16 COARSE THRD LOCK NUT | 2 |
| C968SHIM | GM SHIM - PASS DIFF BRKT | 1 |

Part # HB-C766-BL

| Item # | Description | Qty |
|-----------|-----------------------------|-----|
| C736ABS-B | GM FRONT ABS BRACKET | 2 |
| 516X1FTB | 5/16 X 1 FINE THREAD BOLT | 3 |
| 516SAEW | 5/16 SAE WASHER | 6 |
| 516FTN | 5/16" FINE THRD N/I LOCKNUT | 3 |

| Item # | Description | Qty |
|------------|-------------------------|-----|
| 10MMX30MMB | 10MM X 30MM METRIC BOLT | 4 |
| 38SAEW | 3/8 SAE WASHER | 4 |
| 10MMN | 10 MM LOCK NUT | 4 |

Part # HB-C766TA-NG

| Item # | Description | Qty |
|-----------|------------------------------|-----|
| HG58125 | HOURGLASS 5/8" X 1.25" BUSH | 1 |
| 403712 | ES22 SLEEVE / 1.25" LONG | 1 |
| 12X212FTB | 1/2 X 2 1/2 FINE THREAD BOLT | 1 |
| 12FTN | 1/2 FINE THREAD LOCK NUT | 1 |
| 12SAEW | 1/2 SAE WASHER | 2 |

| Item # | Description | Qty |
|------------|-------------------------------|-----|
| 916X212FTB | 9/16 X 2 1/2 FINE THREAD BOLT | 1 |
| 916FTN | 9/16 FINE THREAD LOCK NUT | 1 |
| 916SAEW | 9/16 SAE WASHER | 2 |
| BTIE-K | BLACK PLASTIC TIE | 2 |

Part # HB-SKD

| Item # | Description | Qty |
|----------|---------------------------|-----|
| 516X1FTB | 5/16 X 1 FINE THREAD BOLT | 4 |
| 516FTN | 5/16 FINE THREAD LOCK NUT | 4 |

| Item # | Description | Qty |
|---------|-----------------|-----|
| 516SAEW | 5/16 SAE WASHER | 8 |

Component Box Breakdown:

Part #: C7661ST

| Item # | Description | Qty |
|---------|----------------|-----|
| C760STS | 6" GM STRUT | 2 |
| 10MMN | 10 MM LOCK NUT | 4 |

| Item # | Description | Qty |
|--------|---------------------------|-----|
| 38SAEW | 3/8 SAE WASHER | 4 |
| I-C766 | INST SHEET: 07 6" GM 1500 | 1 |

Component Box Breakdown:

Part #: C7661PR (Pick Up Models)

| Item # | Description | Qty |
|--------|-----------------|-----|
| RB45 | 4.5" REAR BLOCK | 2 |

| Item # | Description | Qty |
|--------------|---------------------------------|-----|
| 916X212X1312 | U-BOLT WITH 9/16 FINE THRD NUTS | 4 |

Component Box Breakdown:

Part #: C7661PRS (Pick Up Models)

| Item # | Description | Qty |
|---------------|---------------------------------|-----|
| 916X212X1012U | U-BOLT WITH 9/16 FINE THRD NUTS | 4 |

Component Box Breakdown:

Part #: C7661SR (SUV Models)

| Item # | Description | Qty | Item # | Description | Qty |
|-----------|-------------------------|-----|-------------|-----------------------------|-----|
| ARLBD-B | GM SUV REAR DRV LK BRK | 1 | HB-C963RCAB | HDW BAG:C963 RR CONTROL BRK | 1 |
| ARLBP-B | GM SUV REAR PAS LK BRK | 1 | HB-C963RBS | HDWR BAG:C963 RR BUMP STOPS | 1 |
| ARBP42-B | GM SUV REAR BUMP STOP | 2 | HB-RSBL963 | HDWR BAG:C963 REAR END LKS | 1 |
| C766RTB-B | 6" GM REAR TRK BAR BRKT | 1 | HB-C766RTB | HDWR BAG:C766 REAR TRK BRKT | 1 |
| SBE506-L | REAR,SWAY BAR END LINK | 2 | C50RS | GM 4-5" SUV COIL SPRING | 2 |

Hardware Bag Breakdown:

Part # HB-C963RCAB

| Item # | Description | Qty | Item # | Description | Qty |
|------------|-------------------------------|-----|---------|--------------------------|-----|
| 916X312FTB | 9/16 X 3 1/2 FINE THREAD BOLT | 2 | 12FTN | 1/2 FINE THREAD LOCK NUT | 2 |
| 916X4FTB | 9/16 X 4 FINE THREAD BOLT | 2 | 916SAEW | 9/16 SAE WASHER | 8 |
| 12X114FTB | 1/2 X 1 1/4 FINE THREAD BOLT | 2 | 12SAEW | 1/2 SAE WASHER | 4 |
| 916FTN | 9/16 FINE THREAD LOCK NUT | 4 | SS1545 | SLEEVE: ARLBD-B DRIVER | 1 |

Part # HB-C963RBS

| Item # | Description | Qty | Item # | Description | Qty |
|----------|---------------------------|-----|---------|-----------------|-----|
| 716X1FTB | 7/16 X 1 FINE THREAD BOLT | 4 | 716SAEW | 7/16 SAE WASHER | 8 |
| 716FTN | 7/16 FINE THREAD LOCK NUT | 4 | | | |

Part # HB-RSBL963

| Item # | Description | Qty | Item # | Description | Qty |
|---------------|--------------------------|-----|---------|--------------------------|-----|
| HOURGLASS 5/8 | HOURGLASS 5/8 BUSHING | 4 | 12SAEW | 1/2 SAE WASHER | 8 |
| 142121 | ES24 SLEEVE, 1.38" LONG | 4 | 38X1FTB | 3/8 X 1 FINE THREAD BOLT | 2 |
| 12X3FTB | 1/2 X 3 FINE THREAD BOLT | 4 | 38FTN | 3/8 FINE THREAD LOCK NUT | 2 |
| 12FTN | 1/2 FINE THREAD LOCK NUT | 4 | 38SAEW | 3/8 SAE WASHER | 2 |

Part # HB-C766RTB

| Item # | Description | Qty | Item # | Description | Qty |
|------------|-------------------------------|-----|---------|---------------------------|-----|
| 916X112FTB | 9/16 X 1 1/2 FINE THREAD BOLT | 1 | 916SAEW | 9/16 SAE WASHER | 4 |
| 916X312FTB | 9/16 X 3 1/2 FINE THREAD BOLT | 1 | 916FTN | 9/16 FINE THREAD LOCK NUT | 2 |

Front Installation:

1. With the vehicle on flat level ground, set the emergency brake & block the rear tires / wheels. Place a floor jack under the lower control arm's front cross member & raise the front of the vehicle. Place jack stands under the frame rails behind the front wheel wells & lower the frame onto the jack stands.
2. Remove the front tires / wheels using a 22mm socket. (See Photo # 1)
3. Remove the OEM tie rod end nuts from the OEM steering knuckles using a 18mm socket. Remove the OEM tie rod ends from the OEM steering knuckles using a tie rod puller or similar tool. (See Photo # 2)
4. Remove the OEM brake calipers from the OEM rotors & disconnect the OEM brake lines from the OEM upper A-arms. (See Photo # 3) Simply wire the OEM brake calipers out of the way. It will not be necessary to disconnect the OEM brake lines from the OEM brake calipers at this time.
5. Remove the OEM sway bar end links using a 15mm socket & remove the OEM sway bar. (See Photo # 4) Remove the three OEM upper strut retaining nuts using a 18mm socket. (See Photo # 5)
6. Disconnect the OEM upper & lower A-arms from the OEM steering knuckles using a 18mm socket. It may be necessary to strike the side of the steering knuckle to dislodge the OEM ball joints. Be careful not to damage the OEM ball joints. (See Photo # 6)

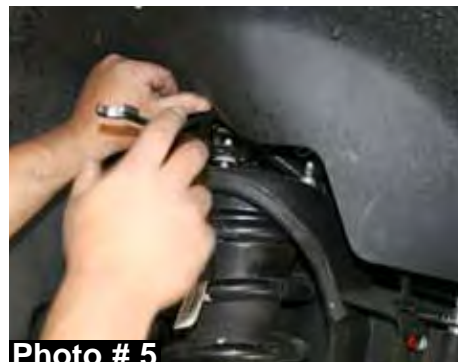

7. Remove the OEM CV axles using a 15mm socket. (See Photo # 7)
8. Remove the OEM front skid plates using a 15mm socket. Remove the OEM lower A-arms using a 18mm & 24mm socket.
9. Remove the OEM rear cross member using a 18mm socket. (See Photo # 8)
10. Disconnect the OEM front drive shaft from the front differential & support the front differential using a transmission jack. Remove the front differential mounting bolts using a 15mm & 18mm socket. (See Photo # 9) Remove the front differential.
11. It will be necessary to cut the driver side frame rail where the OEM rear cross member was located. Measure toward the frame 3.5" & cut using a reciprocating saw or similar tool. (See Photo # 10) **Note:** It will be necessary to grind the forward lip on the frame for clearance of the supplied CV axle spacers. (See Arrow in Photo # 10)
12. It will be necessary to modify the passenger side differential pad for clearance. Measure from the backside of the differential mount bolt location toward the rear of the pad. Mark a line at 5/8" & cut using a reciprocating saw or similar tool. (See Photo # 11)
13. Install the new Skyjacker driver & passenger differential brackets using the OEM hardware. Be sure to install so the tallest portion of the new bracket is towards the front of the vehicle. Install the front differential using the supplied 9/16" x 2" coarse thread bolts, washers, & nuts on the passenger side & the 1/2" x 2" fine thread bolts, washers, & nuts on the driver side. Be sure to use the supplied square shim under the passenger side differential pad where it was previously cut. (See Photo # 12) Reconnect the OEM front drive shaft.



Photo # 7



Photo # 8



Photo # 9

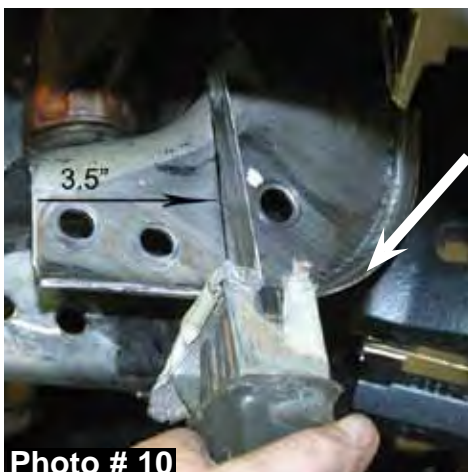

Photo # 10



Photo # 11



Photo # 12

14. Install the new Skyjacker rear cross member using the supplied 5/8 x 5 1/2" fine thread bolts, washers, & nuts. (See Photo # 13)



15. **Note:** It will be necessary to to grind the inside lower corners of the OEM cross member for proper fitment of the new Skyjacker front cross member. (See Arrows Photo # 14) Install the new Skyjacker front cross member using the supplied 5/8" x 4 1/2" fine thread bolts, washers, & nuts. (See Photo # 15)



16. Install the new Skyjacker anti torque arm using the supplied bushing & sleeve in the eye of the new anti torque arm. Attach the eye of the new anti torque arm assembly the new Skyjacker front cross member using the supplied 1/2" x 2 1/2" fine thread bolt, washers, & nut. Attach the lower ear to the front differential using the supplied 9/16" x 2 1/2" fine thread bolt, washers, & nut. (See Arrow Photo # 15)

17. Install the new Skyjacker front differential skid plate to the new front & rear cross members using the supplied 5/16" x 1" bolts, washers, & nuts. (See Photo # 16)

18. Install the OEM A-arms to the new Skyjacker cross members using the OEM hardware.

19. Remove the OEM hub bearing assemblies from the OEM steering knuckles using a 15mm socket. Install the OEM hub bearing assemblies to the new Skyjacker steering knuckles using the OEM hardware.

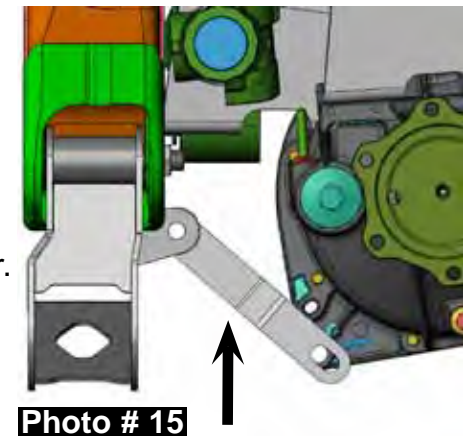

20. Disassemble the OEM strut assemblies using a strut compressor. Remove the OEM coil seat & spacer ring from the OEM strut assemblies. (See Photo # 17) **Note:** There are three snap ring grooves located on the new Skyjacker strut body. The ring is installed in the middle groove when shipped. This will yield 6" of lift. The upper groove is only to be used when 6" of lift is desired, but if aftermarket accessories have been added that weigh the front end down such as a winch or after market bumper. The lower ring can be used if you would like to keep the OEM rake. (Front of the vehicle lower than the rear). Install an OEM spacer ring & coil seat on to each new Skyjacker strut assembly. **Once the coil spring seat retaining ring has been installed check all suspension components for any contact or interference. If suspension component contact or interference is present, lower the coil spring seat retaining ring until no contact or interference is present.**



21. Install the new Skyjacker bump stop with the wider portion towards the new strut body. (See Photo # 18)

22. Assemble the new Skyjacker strut using the OEM coil spring & upper mount. (See Photo # 19)

23. Install the new strut assemblies using the OEM bolts & supplied 10mm nuts. (See Photo # 20) Install at the top using the OEM hardware.

24. Install the new Skyjacker steering knuckles to the upper & lower A-arms using the OEM hardware. Install the OEM CV axles using the new Skyjacker CV axle spacers. Install using the supplied 10mm x 70 mm bolts & thread locking compound. (See Photo # 21)

25. Attach the OEM ABS lines to the new steering knuckle using the supplied 5mm x 12mm bolts.

26. Install the new Skyjacker ABS line brackets using the supplied 5/16" x 1" fine thread bolts, washers, & nuts. (See Photo # 22) Install the new Skyjacker brake lines using the supplied instruction sheet.

27. In order to maintain OEM alignment specifications, the OEM inner & outer tie rods must be cut to obtain proper toe in. Remove the OEM outer tie rods from the OEM inner tie rods. Leaving the OEM jam nuts screwed onto the OEM inner tie rods, measure 1/2" from the ends of the OEM inner tie rods & make a mark. Measure 1/2" from the ends of the OEM outer tie rods & make a mark. Using a cut-off wheel or similar tool, cut along these marks. Unscrew the OEM jam nuts to chase the threads of the OEM inner tie rods. Reinstall the OEM outer tie rods to the OEM inner tie rods. The driver & passenger side OEM tie rods must be cut & adjusted equally to allow for proper toe in adjustment. (See Photo # 23)

28. Install the OEM outer tie rods to the new steering knuckles using the OEM hardware. Reinstall the OEM brake rotors & OEM brake calipers. **Note:** On some models it may be necessary to trim the OEM dust shield for proper brake caliper fitment. (See Photo # 24 & # 25)



Photo # 18



Photo # 19



Photo # 20

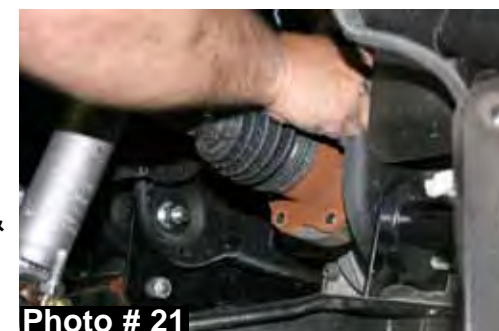

Photo # 21



Photo # 22

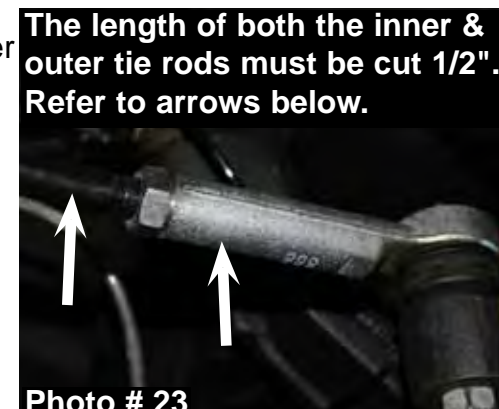

Photo # 23



Photo # 24

I-C766



Photo # 25

29. Reinstall the OEM sway bar using the new Skyjacker drop brackets. The new brackets will install between the OEM sway bar & the OEM mount on the frame using the supplied 10mm x 30mm bolts, washers, & nuts. (See Photo # 26) Install the new Skyjacker sway bar end links. Be sure to install the new end link with the pivoting end at the A-arm. The gold washer should be on top of the A-arm, with the nut on the bottom. (See Photo # 27)



Photo # 26

30. **Pick-Up Models:** Block the front tires / wheels, raise the rear of the vehicle, & properly support the frame using jack stands. Remove the OEM rear shocks using a 21mm socket & OEM U-bolts. Support the rear differential & install the new Skyjacker 4.5" rear lift blocks (thick end towards the rear) along with the new Skyjacker U-bolts. (See Photo # 28) If installing Skyjacker Softride rear leaf springs, simply remove the OEM leaf spring & replace. **Note:** If changing rear leaf springs, it will be necessary to lower the gas tank to gain access to the forward leaf spring bolt. **Note:** If your model is equipped with rear ABS lines, remove the OEM ABS lines from the plastic connectors on the frame & attach the OEM ABS lines to the outside of the new U-bolts using the supplied plastic ties. (See Photo # 29)



Photo # 27

31. Lower the rear of the vehicle to the ground & proceed to Step # 46.



Photo # 28

32. **SUV Models:** Block the front tires / wheels, raise the rear of the vehicle, & properly support the frame using jack stands. Remove the OEM rear shocks using a 21mm socket. Disconnect the OEM rear sway bar end links. (See Photo # 30)



Photo # 29

33. Loosen the OEM lower & upper control arm bolts using a 21mm socket. (See Photo # 31)

34. Disconnect the OEM emergency brake cable from the driver side axle & passenger side frame using a 13mm socket. Disconnect the OEM brake line from the center of the axle.



Photo # 31



Photo # 30

35. Lower the axle & remove the OEM coil springs. Be sure to retain the OEM upper & lower rubber isolator pads. (See Photo # 32)
36. Disconnect the OEM upper & lower control arms from frame rail. Only remove one side at a time so the axle does not move. Install the new Skyjacker upper / lower arm relocation bracket .



Photo # 32

Note: On the driver side only, be sure to install the supplied anti-crush sleeve into the OEM upper control arm position. (The sleeve is welded to the new Skyjacker bracket on the passenger side).

37. Install the new Skyjacker upper / lower arm relocation brackets using the OEM hardware in the OEM locations. Attach the upper arms to the new Skyjacker brackets using the supplied 9/16" x 3 1/2" fine thread bolts, washers, & nuts. Attach the lower control arms to the new Skyjacker brackets using the supplied 9/16" x 4" fine thread bolts, washers, & nuts. (See Photo # 33) Be sure to install the supplied 1/2" x 1 1/4" fine thread bolt, washers, & nut into the bottom of each new bracket. The bolt will line up with the OEM hole in the bottom of the frame. (See Arrow in Photo # 34)



Photo # 33

38. Loosen the OEM track bar mount bolt on the differential using a 21mm socket. Remove the OEM track bar bolt from the frame.
39. Install the new Skyjacker track bar bracket by sliding it into the OEM bracket. Install using the supplied 9/16" x 3 1/2" fine thread bolts, washers, & nut in the OEM bolt hole.



Photo # 34

40. It will be necessary to drill a new hole through the back of the OEM bracket into the new Skyjacker bracket. It is recommended to first drill a small pilot hole, then drill using a 9/16" drill bit.
41. Once drilled, install the supplied 9/16" x 1 1/2" fine thread bolt, washers, & nut. (See Photo # 35)
42. Attach the rearward hole of the new Skyjacker bump stop brackets to the OEM mounting holes on the axle using the supplied 7/16" x 1" fine thread bolts, washers, & nuts. To access the front mounting hole, it will be necessary to lower the bottom control arm out of the way. (See Photo # 36)



Photo # 35

43. Mark & drill the front hole using a 29/64" drill bit. Once drilled, install the supplied 7/16" x 1" fine thread bolts, washers, & nuts.



Photo # 36

44. Install the new Skyjacker coil springs using the OEM upper & lower rubber isolator pads. (See Photo # 37) Once installed, carefully load the rear suspension & attach the OEM rear track bar to the new Skyjacker bracket using the OEM hardware.

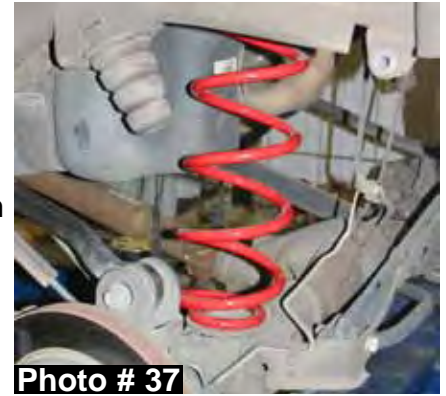

45. Insert the supplied 5/8" polyurethane hourglass bushings into each end of the new Skyjacker sway bar end links. Insert the supplied 1/2" x 1 1/2" sleeves into each new bushing. Attach the new sway bar end links to the OEM mounts using the supplied 1/2" x 3" fine thread bolts, washers, & nuts. (See Photo # 38)



46. Install the new Skyjacker rear brake line relocation bracket to the axle using the OEM hardware & attach the OEM brakeline to the new Skyjacker bracket using the supplied 5/16" x1" fine thread bolt, washers, & nut. (See Photo # 39)

47. Lower the rear of the vehicle to the ground & install the new Skyjacker rear shocks.



FINAL NOTES:

- After the installation is complete, double check that all nuts & bolts are tight. Refer to the following chart again for the proper torque specifications. (Do not retighten the nuts & bolts where thread lock compound was used.)
- With the vehicle placed on the ground, cycle the steering lock to lock & inspect the steering, suspension, brake lines, front & rear drivelines, fuel lines, & wiring harnesses for proper operation, tightness, & adequate clearance.
- Have the headlights readjusted to the proper settings.
- Have a qualified alignment center realign the front end to the factory specifications.
- Retorque all the bolts after the first 100 miles.

| TORQUE SPECIFICATIONS | | | | | |
|------------------------------|----------------|----------------|----------------------|------------------|-------------------|
| INCH SYSTEM | | | METRIC SYSTEM | | |
| Bolt Size | Grade 5 | Grade 8 | Bolt Size | Class 8.8 | Class 10.9 |
| 5/16 | 15 FT LB | 20 FT LB | 6MM | 5 FT LB | 9 FT LB |
| 3/8 | 30 FT LB | 35 FT LB | 8MM | 18 FT LB | 23 FT LB |
| 7/16 | 45 FT LB | 60 FT LB | 10MM | 32 FT LB | 45 FT LB |
| 1/2 | 65 FT LB | 90 FT LB | 12MM | 55 FT LB | 75 FT LB |
| 9/16 | 95 FT LB | 130 FTLB | 14MM | 85 FT LB | 120 FT LB |
| 5/8 | 135 FT LB | 175 FT LB | 16MM | 130 FT LB | 165 FT LB |
| 3/4 | 185 FT LB | 280 FTLB | 18MM | 170 FT LB | 240 FT LB |

***The above specifications are not to be used when bolt is being installed with a bushing.**

Seat Belts Save Lives, Please Wear Your Seat Belt.



Jesus Forgives,
Rocks Don't

Jesus Christ Died For You.

John 3:16

For God so loved the world that He gave His only Son, so that everyone who believes in Him should not perish, but have everlasting life.
Romans 3:23

For all have sinned; all fall short of God's glorious standard.
Ephesians 2:8

God saved you by his special favor when you believed. And you can't take credit for this; it is a gift from God.
Psalms 18:2

The Lord is my Rock, my fortress, and my savior; my God is my Rock, in whom I find protection. He is my shield, the strength of my salvation, and my stronghold.
Romans 10:9-10

That if you shall confess with thy mouth the Lord Jesus, and shall believe in your heart that God hath raised him from the dead, you shall be saved. For with the heart man believeth unto righteousness; and with the mouth confession is made unto salvation.

Pray This Simple Prayer:
God, I come to You admitting I have sinned against You and I need you to take control of my life. The Bible says anyone who calls on the name of the Lord will be saved. I am calling on You, Jesus. I ask that You come live in my heart and be the Lord over my life today. I do believe You died on the cross for me and came back to life to give me life! Thank You, Lord Jesus for a new life in You!

Now, go and tell somebody about your new life in Jesus, get a Bible, begin to read it, and go to a Bible believing church.

If you would like someone to pray with you, call Kenneth Copeland Ministries anytime at 800-600-7395.

To listen to commercial free Christian radio on the web, go to www.887fm.org

Jesús murió por ti.

Juan 3:16

"Porque tanto amó Dios al mundo, que dio a su Hijo unigénito, para que todo el que cree en él no se pierda, sino que tenga vida eterna."
Romanos 3:23

"Pues todos han pecado y están privados de la gloria de Dios."
Efesios 2:8

"Porque por gracia ustedes han sido salvados mediante la fe; esto no procede de ustedes, sino que es el regalo de Dios."
Salmos 18:2

"El Señor es mi roca, mi amparo, mi libertador; es mi Dios, el peñasco en que me refugio. Es mi escudo, el poder que me salva, ¡mi más alto escondite!"
Romanos 10:9-10

"9 Que si confi esas con tu boca que Jesús es el Señor, y crees en tu corazón que Dios lo levantó de entre los muertos, serás salvo. 10 Porque con el corazón se cree para ser justifi cado, pero con la boca se confi esa para ser salvo."

Ahora dí esta simple oración:
Dios, vengo a Ti y admito que he pecado contra Ti, necesito que tomes el control de mi vida. La Biblia dice que todo aquel que invoca el nombre del Señor escapará con vida. En este momento yo clamo ante Ti, Jesús; te pido que vengas a vivir en mi corazón y que tomes el control de mi vida. ¡Yo creo que tu moriste en la cruz y resucitaste para darme vida! ¡Gracias Señor Jesús, por una nueva vida que tengo en Ti! Amen.

Ahora ve y dile a alguien sobre la nueva vida que tienes en Cristo. Compra una Biblia y empieza a leerla. Busca una Iglesia que cree en la Biblia y hazte parte de esa Iglesia.

Si te gustaría orar con alguien, puedes llamar a este número 800-600-7395

Puedes ir a este sitio de Internet para escuchar música Cristiana sin anuncios, www.887fm.org

Check out our favorite ministries at:

www.innministries.org

www.familychurch.org

www.kcm.org

