

Trailer SumoSprings®

TSS-101-40

Lippert Axle, GAWR: 4000-8000

Spring-Over Axle Configuration

ITEM NO.	PART NUMBER	DESCRIPTION	QTY.
1	511453	SumoSpring	2
2	512122	Mounting Bracket	2
3	512116	3" x 1/2" Spacer	6
4	512330	M8-1.25 x 30mm Hex Bolt Use with 0-1 spacer	2
	512333	M8-1.25 x 50mm Hex Bolt Use with 2 spacers	2
	512249	M8-1.25 x 55mm Hex Bolt Use with 3 spacers	2
5	512215	M8 Flat Washer	2
6	512329	L-Shaped Square U-Bolt	4
7	112208	5/16 Nyloc Nut	8
8	112209	5/16 Flat Washer	8

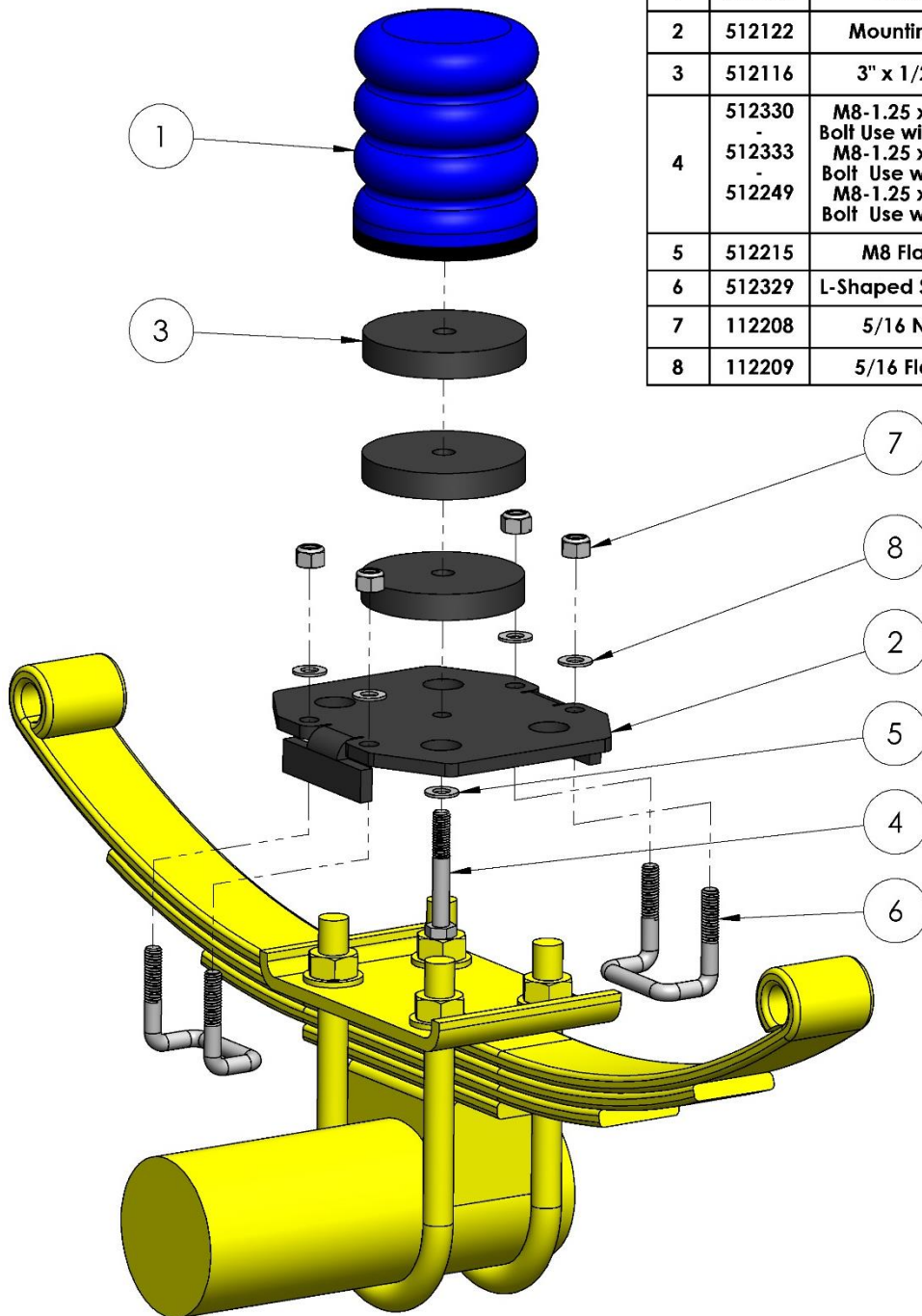

Installation Instructions

1. Position vehicle on a smooth level surface and adjust so that the frame is level to the ground. DO NOT RAISE THE TRAILER FOR THIS STEP. Place mounting bracket (Item 2) onto leaf spring top plate with the 4 holes located over the ends of the factory u-bolts. Measure from the top of the mounting bracket to the bottom of the frame as seen below.



2. Find a combination of 1 SumoSpring (Item 1) and 1-3 of the spacers (Item 3) that will stack up to a height of $\frac{1}{4}$ " - $\frac{1}{2}$ " taller than the measurement from Step 1. This will allow the SumoSpring to be installed with the desired amount of $\frac{1}{4}$ " - $\frac{1}{2}$ " of preload.
3. Using the correct length 8mm bolt (Item 4) and 8mm flat washer (Item 5) bolt the combination of spacers and SumoSpring to the mounting bracket as seen in exploded view on page 1.
4. Ensuring that the trailer is secure, raise the frame so that the axle is separated from the frame sufficient to place the SumoSpring/bracket assembly on top of the factory spring plate with the four holes of the bracket located on the ends of the u-bolts as in Step 1.

5. Install one L-shaped square u-bolt on each side of the mounting bracket so that it hooks under the factory spring plate and attach with 5/16" flat washers (Item 8) and 5/16 lock nuts (Item 7) as seen below. The nuts should only be snugged down to prevent bending of the L-shaped u-bolt. **Torque no more than 60 in./lbs. (5 ft./lbs.)**



6. Repeat steps 3-5 at each wheel. Lower trailer to the ground and check preload on SumoSprings.



Important Notice.

- 1) For easy installation please read instructions completely first and have all necessary tools available.
- 2) We recommend that this installation be done by a professional or persons with sound mechanical knowledge.
- 3) SumoSprings are designed to work with the original factory springs only. If they have been replaced with aftermarket springs then please consult with Supersprings International at 866-898-0720.
- 4) These instructions are meant as a guide for the installation of SumoSprings. SuperSprings International assumes no liability for the actual installation process. Installers should apply common automotive safety practices when raising, lowering and working on vehicles.
- 5) SumoSprings are designed to enhance the vehicles load carrying performance and road handling however it does not authorize (or recommend) loading beyond the manufacturer's GVWR specifications.
- 6) For technical support contact SuperSprings International at 866-898-0720.
Or email to: tech@supersprings.com