

PART NUMBER

**SSF-603-40**



**BEFORE YOU BEGIN**

**PRIMARY APPLICATION**

- › ISUZU NPR 2WD (2010-present)

**TOOLS REQUIRED**

- › Floor jack
- › Safety jack stands
- › 9/16" Wrench/Socket
- › 5mm Allen Wrench

**PARTS LIST**

Item	Part #	Description	QTY
A	511440	SumoSprings Blue -40	2
B	512139	Mounting Bracket	2
C	512218	M8 x 25MM FHCS	2
D	512047	Lower Bracket U-Strap	2
E	512323	3/8" -16 Nyloc Nut	4
F	512247	3/8" -16 X4" Carriage Bolt	4
G	512227	3/8" USS Flat Washer	4
H	512239	Loctite Sachet	1

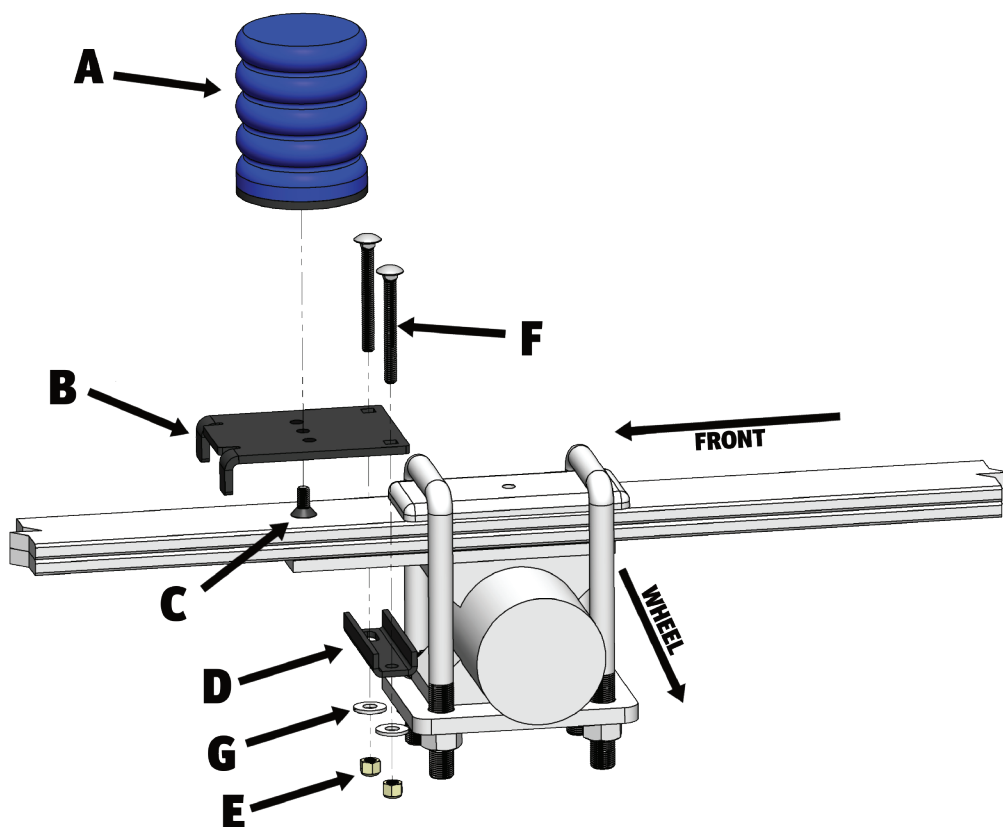

**PASSENGER SIDE (DRIVER'S SIDE SIMILAR)**

**Part Number: SSF-603-40**

**Product Line: SUMOSPRINGS FRONT**

**Page 1**

**SuperSprings International, Inc.**

505 Maple Avenue  
Carpinteria, CA 93013

**Installation Support**

+1 (800) 898-0705  
support@supersprings.com

[supersprings.com](http://supersprings.com)

**SAFETY NOTICE:** We recommend installation be done by a professional or persons with sound mechanical knowledge.

**WARNING:** These instructions are a general guide for installation. SuperSprings International, Inc. assumes no liability for the actual installation process. Consumers and installers should apply common automotive safety practices when raising and working on any vehicle. **Do not put yourself in a position where, if the vehicle were to move unexpectedly, you may be injured.** SuperSprings' products are designed to improve vehicle ride quality. Do not load any vehicle beyond the manufacturer's specifications.

**Never exceed the manufacturer's Gross Vehicle Rating (GVWR) located on your vehicles identification tag.**

**BEFORE INSTALLATION:** Ensure the vehicle is on a level surface, the parking brake is ON, with the ignition OFF, and place blocks in front of and behind the front tires to prevent the vehicle from moving.

**DURING AND/OR AFTER INSTALLATION:** Ensure emergency brake cables are not touching the SuperSprings. Secure any cables out of the way with zip ties or by re-routing. **Ensure all A/C lines, brake cables, and frame are clear of contact or interference.**

PART NUMBER

**SSF-603-40**



**IMPORTANT NOTICE:** Your part may have been loosely preassembled to show the final product as it will be once installed on your vehicle. Please disassemble the product before proceeding to the installation.

**INSTALLATION**

1. Park the vehicle on a hard, level surface and engage the emergency brake. Place blocks in front and behind the wheels to prevent rolling. Observe all safety precautions and wear safety glasses.
2. Raise the front of the vehicle allowing the axle to hang freely and rest the frame on the safety jack stands rated for the weight of the vehicle.
3. Starting on the either side, unscrew the two bolts and remove the factory bump stop from the underside of the frame.
4. Apply a drop of Loctite to the threads of the M8 X 25 mm bolt [ITEM C] and attach the Mounting Bracket [ITEM B] to the top of the SumoSprings [ITEM A].
5. If the leaf springs are centered under the frame, use the middle hole. If the leaf springs are offset from the frame, use the outer holes. In either case, ensure the SumoSprings sit directly under the frame.
6. Place the lower bracket with the attached SumoSprings on top of the factory leaf pack just in front of the axle. Make sure you position the flange for the mounting bolts toward the rear, closest to the axle u-bolts and slide the bracket back so that the edge of the bracket is in contact.
7. Place the two 3/8" -16 X 4" Carriage Bolts [ITEM F] through the square holes in the mounting bracket and slide the Lower Bracket U-Strap [ITEM D] over the ends of the carriage bolts with that the "U" shape is facing up. Fasten together using the two 3/8" - 16 Nyloc Nuts [ITEM E]. *(Tighten the nuts snugly but not tight. They will be torqued later).*
8. Repeat steps 3 – 7 on the other side of the vehicle.
9. Raise the vehicle, remove safety jack stands, and carefully lower vehicle to the hard surface. Remove the blocks in front and back of the rear wheels and release the emergency brake.
10. Once the vehicle is lowered to the surface, torque the 3/8" - 16 Nyloc Nuts [ITEM E] (from step 7) to 20 ft. lbs.
11. Register the warranty for your SuperSprings International part. A warranty card can be found in the box your part came in.

**Part Number: SSF-603-40**

**Product Line: SUMOSPRINGS FRONT**

**Page 2**

**SuperSprings International, Inc.**  
505 Maple Avenue  
Carpinteria, CA 93013  
**Installation Support**  
+1 (800) 898-0705  
support@supersprings.com  
**supersprings.com**

**SAFETY NOTICE:** We recommend installation be done by a professional or persons with sound mechanical knowledge.  
**WARNING:** These instructions are a general guide for installation. SuperSprings International, Inc. assumes no liability for the actual installation process. Consumers and installers should apply common automotive safety practices when raising and working on any vehicle. **Do not put yourself in a position where, if the vehicle were to move unexpectedly, you may be injured.** SuperSprings' products are designed to improve vehicle ride quality. Do not load any vehicle beyond the manufacturer's specifications.

**Never exceed the manufacturer's Gross Vehicle Rating (GVWR) located on your vehicles identification tag.**  
**BEFORE INSTALLATION:** Ensure the vehicle is on a level surface, the parking brake is ON, with the ignition OFF, and place blocks in front of and behind the front tires to prevent the vehicle from moving.  
**DURING AND/OR AFTER INSTALLATION:** Ensure emergency brake cables are not touching the SuperSprings. Secure any cables out of the way with zip ties or by re-routing. **Ensure all A/C lines, brake cables, and frame are clear of contact or interference.**