



**Superlift 6" lift system for 2001 – 2006
Chevrolet Silverado / GMC Sierra 1500HD and 2500 (non-HD) and Avalanche / Suburban /
Yukon XL 3/4-ton 4WD
INSTALLATION INSTRUCTIONS**

INTRODUCTION

Installation requires a professional mechanic. Prior to beginning, inspect the vehicles steering, driveline, and brake systems, paying close attention to the suspension link arms and bushings, anti-sway bars and bushings, tie rod ends, pitman arm, ball joints and wheel bearings. Also check the steering sector-to-frame and all suspension-to-frame attaching points for stress cracks. The overall vehicle must be in excellent working condition; repair or replace all worn parts.

Read instructions several times before starting. Be sure you have all needed parts and know where they install. Read each step completely as you go.

NOTES:

- **Prior to beginning the installation, check all parts and hardware in the box with the parts list below. If you find a packaging error, contact Superlift directly. Do not contact the dealer where the system was originally purchased. You will need the control number from each box when calling; this number is located at the bottom of the part number label and to the right of the bar code.**
- Exhaust modifications are required on vehicles equipped with a gas engine; vehicles with a diesel engine do not require exhaust modifications.
- The factory wheels cannot be used with larger-than-stock tires. The factory spare tire and wheel can be used in emergency situations.
- This system requires the use of wheels with a minimum of 4-5/8" of backspacing, and a maximum of 5".
- The factory steering stabilizer can be re-used with this lift system; order part #92050 as an optional replacement.
- Rear lift is sold separately and includes separate instructions.
- A special tool is required to load/unload the torsion bars (step 2). Other special tools are recommended to detach/attach the pitman/idler studs. Refer to the factory service manual.
- Front end re-alignment is necessary.
- This system utilizes the stock torsion bars, which normally yield the best ride quality. But, if the "final product" ride and handling seem too soft, heavier Gross Vehicle Weight Rating (GVWR) bars can be installed. Generally, heavier torsion bars are only needed to compensate for the extra weight of a winch or snowplow, or when the truck is subjected to extreme off-road use. Also, wider tires and wheels proportionally increase the leverage on the bars, which results in lower ride height and a "spongier" ride. GM offers torsion bars with various rates that are heavier than stock. Your vehicle's existing torsion bar rate can be identified by a 3-letter code stamped into the bars' ends. The code is also on an adhesive tag wrapped around the bars.

- An arrow on diagrams indicates which direction is toward the front of the vehicle.
- A foot-pound torque reading is given in parenthesis () after each appropriate fastener.
- Do not fabricate any components to gain additional suspension height.
- Prior to drilling or cutting, check behind the surface being worked on for any wires, lines, or hoses that could be damaged.
- After drilling, file smooth any burrs and sharp edges.
- Prior to operating a torch or saw, protect any heat-sensitive components located in the immediate area by covering them with a water-saturated cloth. Most undercoating are flammable but can be extinguished using a water-filled spray bottle. Have a spray bottle and an ABC rated fire extinguisher on hand.
- Paint or undercoat all exposed metal surfaces.
- Prior to attaching components, be sure all mating surfaces are free of grit, grease, undercoating, etc.
- A factory service manual should be on hand for reference.
- Use the check-off box “☐” found at each step to help you keep your place. Two “☐☐” denotes that one check-off box is for the driver side and one is for the passenger side. Unless otherwise noted, always start with the driver side.

PARTS LIST ... The part number is stamped into each part or printed on an adhesive label. Identify each part and place the appropriate mounting hardware with it.

PART NO	DESCRIPTION <small>(Qty.- if more than one)</small>	NEW ATTACHING HARDWARE <small>(Qty.- if more than one)</small>
66-01-3390	driver side knuckle	(2) 1/4" x 1/2" self-tapping bolt (2) wire retaining clamps
66-02-3390	passenger side knuckle.....	(2) 1/4" x 1/2" self-tapping bolt (2) wire retaining clamps
55-03-3320	differential bracket,..... driver side	(1) 9/16" x 4-1/2" bolt (2) 9/16" SAE flat washer (1) 9/16" nyloc nut (2) bushing half (1) 1" OD x 2-7/16" sleeve (1) vent hose extension
55-04-3320	differential drop bracket,..... passenger side	(2) 9/16" x 1-1/2" bolt (2) 9/16" extra-thick flat washer (2) 9/16" USS washer (2) 9/16" nyloc nut
1-07-3320	frame reinforcement plate	
55-05-3320	front crossmember	(2) 5/8" x 4-1/2" bolt (4) 5/8" USS washer (2) 5/8" nyloc nut

55-06-3320 rear crossmember	(2) 5/8" x 5-1/2" bolt (4) 5/8" USS washer (2) 5/8" nyloc nut (1) 9/16" x 3-1/2" bolt (1) 9/16" SAE washer (1) 9/16" nyloc nut
55-08-3320 anti-sway bar drop bracket,..... passenger side	(2) 3/8" x 1-1/4" bolt (4) 3/8" USS washer (2) 3/8" nyloc nut
55-09-3320 anti-sway bar drop bracket,..... driver side	(2) 3/8" x 1-1/4" bolt (4) 3/8" USS washer (2) 3/8" nyloc nut
55-11-3320 front skid plate.....	(2) 5-16" x 1" stainless allen bolt (2) 5/16" SAE washer
55-19-3320 (2) CV axle spacer	(12) 10mm x 70mm bolt (12) 10mm flat washer
55-15-3290 torsion bar drop bracket,	(6) 7/16" x 1-1/4" bolt (12) 7/16" USS washer (6) 7/16" nyloc nut (2) bushing half (1) 3/4" OD x 1-3/4" sleeve
55-16-3290 torsion bar drop bracket,	(6) 7/16" x 1-1/4" bolt (12) 7/16" USS washer (6) 7/16" nyloc nut (2) bushing half (1) 3/4" OD x 1-3/4" sleeve
55-10-3370 (2) kicker brace bracket.....	(2) 7/16" x 1-1/4" bolt (2) 7/16" SAE washer (2) 7/16" tab nut
55-29-3480 (2) kicker brace	(4) 7/16" x 4" bolt (4) 7/16" SAE washer (4) 7/16" nyloc nut (8) bushing half (4) 3/4" OD x 2-5/8" sleeve
44-18-3290 (2) lower shock bracket	
55-19-3290 (2) compression stop.....	(4) 7/16" x 1-1/4" bolt (4) 7/16" nyloc nut
55-26-3280 rear emergency brake cable	(1) 1/4" x 1" bolt (2) 1/4" flat washer (1) 1/4" nyloc nut
 stock rear brake line bracket	(2) 1/4" x 1" bolt (2) 1/4" nyloc nut

- 55-09-3380 carrier bearing drop bracket(2) 7/16" x 1-1/4" bolt
 (2) 7/16" USS washer
 (2) 7/16" nyloc nut
- 058 (2) 5" non-tapered blocks
- 11122..... (4) U-bolts(8) 5/8" extra thick flat washer
 (8) 5/8" nyloc nut
- (2) shock absorber, front(2) shock boot*, yellow
 (2) hardware pack and cable tie
- *(NOTE: Shock boots, if desired, purchased separately)**
- (2) shock absorber, rear(2) shock boot*, yellow
 (2) hardware pack and cable tie
- *(NOTE: Shock boots, if desired, purchased separately)**
- 00461..... decal, "Warning To Driver"

FRONT DISASSEMBLY

1) PREPARE VEHICLE...

- Place the vehicle in neutral. Raise the front of vehicle with a jack and secure a jack stand beneath each frame rail, behind the lower control arms. Ease the frame down onto the stands, place transmission in low gear or "park", and chock rear tires. Remove the front tires.
- Disconnect the battery.

2) UNLOADING THE TORSION BARS...

WARNING: Be extremely careful when loading and unloading the torsion bars; there is a tremendous amount of energy stored in them. Keep your hands and body clear of the adjuster arm assembly and the puller tool in case anything slips or breaks.

- Mark the torsion bars to indicate driver and passenger side.
- A special torsion bar puller tool is required to unload the torsion bars. Use the tool to load the torsion bar, then remove the adjusting bolt and nut block. Unload the bar.

Note: Because of the extreme loads generated by the torsion bars on these vehicles, a standard two-jaw puller tool tends to bend the "lips" of the crossmember (which it uses for attachment) and may pop out of place. We have had the best results using a C-clamp type puller tool. If one cannot be found locally, this tool (PN J-22517-C) is available from the Kent Moore Tool Group in Roseville, Michigan (800/345-2233 or 313/774-9500).

- Once unloaded, scribe an alignment mark on each bar to indicate its indexing in relation to the adjuster arm and the lower control arm.
- Slide the torsion bar forward (into the lower control arm) and remove the adjusting arm.
- Remove the torsion bar crossmember. Slide the torsion bars out of the lower control arms and set these parts aside.

3) BRAKE HOSE AND CALIPER...

- Unbolt the brake hose from the upper control arm, then unbolt the caliper bracket from the knuckle and hang it out of the way using mechanic's wire. Be sure the brake hose isn't stretched or pinched. Retain all the factory hardware.

4) AXLE SHAFT...

- Remove the six bolts that hold the CV axle flange to the differential.

5) TIE ROD ENDS...

- Using a special puller tool (refer to the factory service manual), detach the tie rod end from the knuckle. Leave the tie rods attached to the centerlink.

6) SWAY BAR AND COMPRESSION STOPS...

- Unbolt the sway bar links from the lower control arms, then detach the sway bar from the frame. Retain all the factory hardware and bushings.
- Unbolt the factory compression stops from the frame. Save the stops and hardware for re-use.

7) CONTROL ARM / HUB ASSEMBLY...

- Remove and discard the front shocks. Save the lower shock hardware for re-use.
- Mark the axleshafts' respective positions (Driver and Passenger).
- Remove the dust cap in the center of the wheel bearing assembly in order to gain access to the axle shaft nut. Remove the axle shaft nut, then remove the axle shaft from the vehicle. Save all hardware for re-use.
- Support the control arm / hub assembly with a jack. Remove the upper ball joint nut securing the knuckle to the upper control arm. Using the appropriate puller tool, separate the upper ball joint from the knuckle. Save all hardware for re-use.
- Remove the lower ball joint nut and, using the appropriate puller tool, separate the ball joint from the knuckle. Set the knuckle (with the wheel bearing assembly still attached) aside.
- Remove the bolts that hold the lower control arm to the frame and set the lower control arm aside. Save all hardware for re-use.

8) FRONT DRIVESHAFT...

- Mark the driveshaft in relation to the differential yoke for reference during re-assembly. Detach the front driveshaft from the differential and retain the factory bolts and clamps. Leave the driveshaft attached to the transfer case and tie it up out of the way.

9) SKID PLATE...

- Remove the differential skid plate and splash shield if so equipped.

10) DIFFERENTIAL WIRING...

- Disconnect the differential wiring and vent hose.

11) DIFFERENTIAL ASSEMBLY...

- Remove the factory rear crossmember.
- Support the differential with a floor jack. Remove the bolt that attaches the rear of the differential to the driver side lower control arm frame mount. Save this bolt for re-use.
- Remove the two bolts that hold the differential on the passenger side.
- Remove the last bolt on the top of the differential on the driver side and carefully lower the differential assembly to the floor.

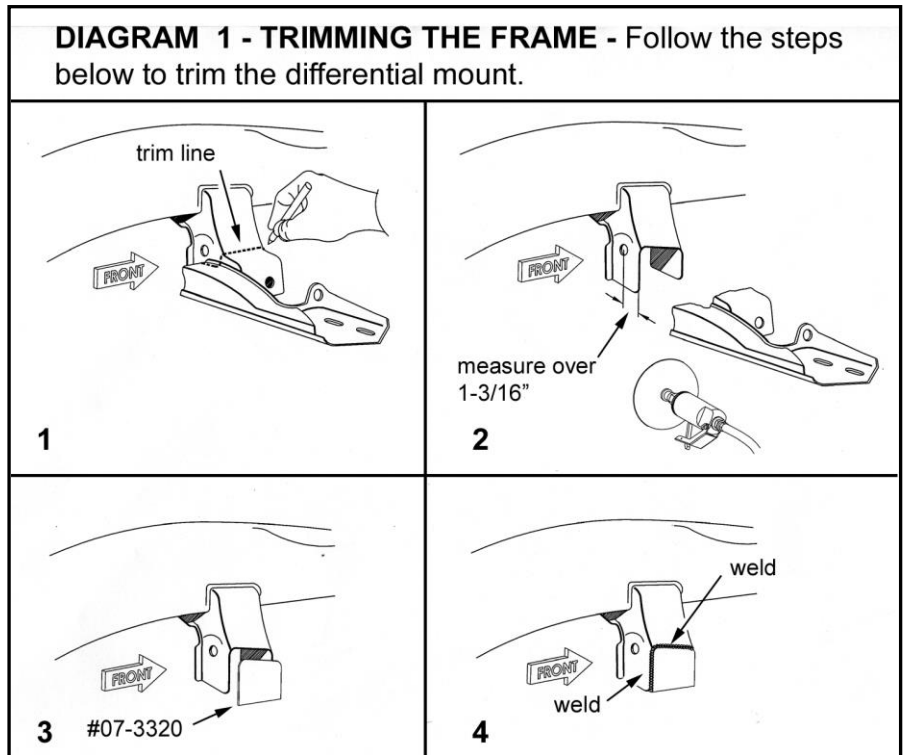

12) TRIMMING THE FRAME...

- [DIAGRAM 1] Trim the driver side differential mount as shown. Measure over 1-3/16" over from the center of the factory LCA mounting hole and mark a vertical cut line. Use a plasma cutter, torch, or similar tool to perform the trimming.
- Test-fit the supplied reinforcement plate (#07-3320) as shown in Diagram 1. It may be necessary to trim the plate or the frame for a proper fit, but care should be taken to be sure the plate fits properly to ensure a proper weld and a clean-looking finished product. Tack-weld the reinforcement plate in place.
- Test-fit the rear crossmember (#55-06-3320) to ensure proper clearance with the reinforcement plate. Remove the crossmember and weld the plate completely. Allow the welds to cool and then paint the affected area.

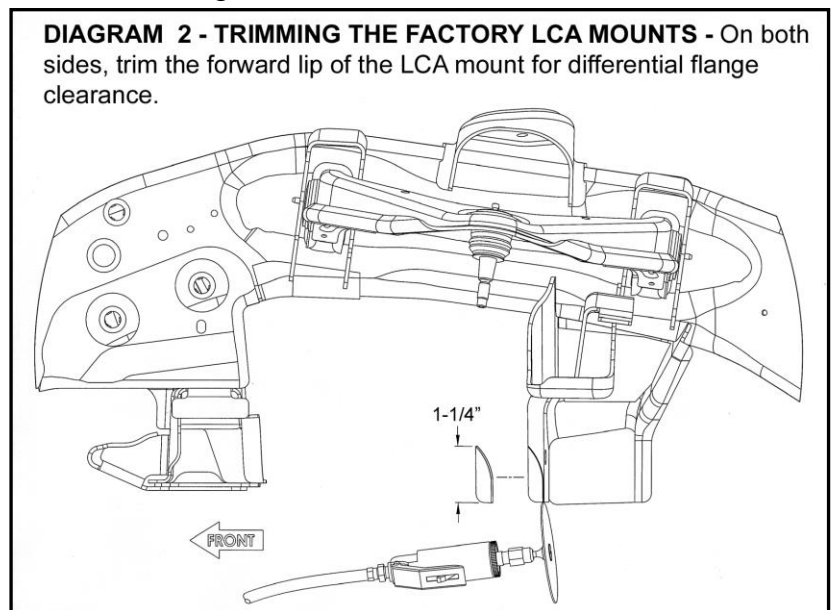

- [DIAGRAM 2] Trim the forward lip on both the driver and passenger side lower control arm mounts as shown for proper differential flange clearance.

FRONT ASSEMBLY

13) FRONT CROSSMEMBER...

NOTE: If the optional replacement steering stabilizer #92050 has been purchased, install now per separate instructions.

- ❑ Attach the front crossmember (#55-05-3320) to the factory lower control arm mounts on the frame and loosely secure using the supplied 5/8" x 4-1/2" bolts, washers, and nyloc nuts. The bolts should be installed from the front. Note that it is necessary to angle the crossmember and slide it into one mount first, then straighten the crossmember and shift it slightly to install it in the remaining mount. Do not tighten the hardware at this time.

14) DIFFERENTIAL MODIFICATIONS...

- ❑ [DIAGRAM 3] Using a hacksaw, cut-off wheel, or similar tool, trim off the upper mounting ear on the differential housing as shown.

WARNING: Do not use a torch or similar tool that generates extreme heat to make the necessary cuts to the differential. Excessive heat will warp the differential housing and irrevocably damage it.

- ❑ Trim the corner off of the passenger side mounting pad as shown in Diagram 3.
- ❑ Lubricate and installed the supplied bushings and sleeve in the driver side upper differential mount (#55-03-3320).

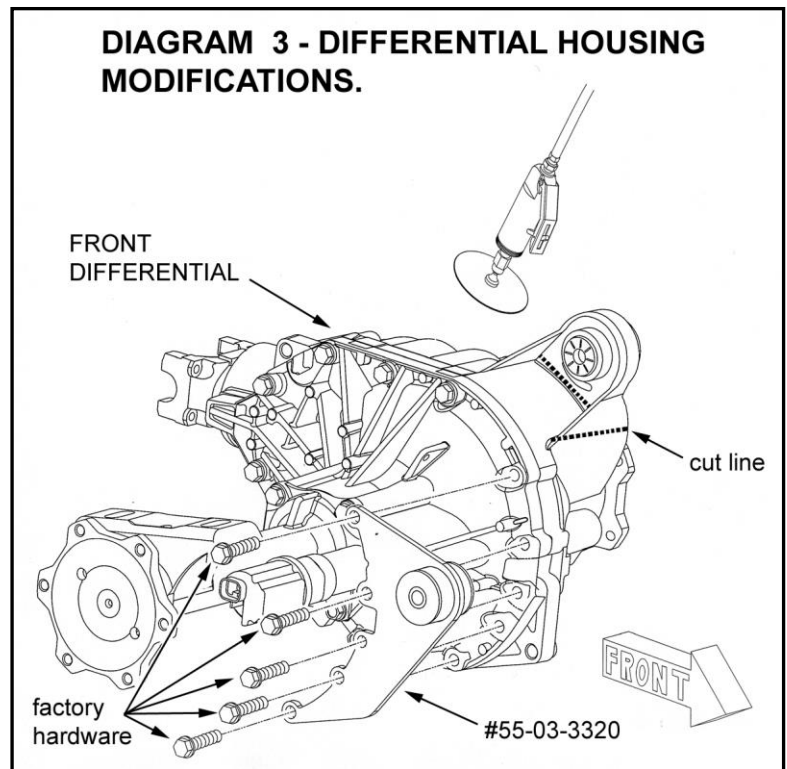

- ❑ [DIAGRAM 3] Remove the factory bolts on the differential and attach the "03" bracket to the housing as shown. Re-install the bolts and tighten (35).

15) DIFFERENTIAL AND REAR CROSSMEMBER INSTALLATION...

- ❑ Look at the passenger side differential drop bracket (#55-04-3320). You will notice it has a taper in it. Position the bracket on the factory mount so that the tall end of the taper faces forward, while the short end of the taper faces rearward. Attach the "04" bracket to the factory mount using the factory hardware. Do not tighten at this time.
- ❑ Using a jack and an assistant, raise the differential housing into position. Attach it to the "04" passenger side mount using the supplied 9/16" x 1-1/2" bolts, extra-thick flat washers, and nyloc nuts. The bolts should be installed from the top, and the thick flat washers should be positioned under the nuts. Do not tighten at this time.

- Line up the driver side front mount with the tabs on the front crossmember and secure using the supplied 9/16" x 4-1/2" bolt. Do not install the washer or nut at this time.
- Raise the rear crossmember (#55-06-3320) into position and attach it the factory LCA rear leg mounts using the supplied 5/8" x 5-1/2" bolts, washers, and nyloc nuts. The bolts must be installed from the front. Do not tighten at this time.
- Secure the driver side rear mount of the differential to the "06" rear crossmember using the factory hardware. Do not tighten at this time.
- Attach the factory compression travel stops to the tabs on the rear crossmember using the factory hardware. Tighten (23).

16) SKID PLATE...

- Support the differential and remove the 9/16" x 4-1/2" bolt securing the differential to the front crossmember on the driver side. Line up the front skid plate (#55-11-3320) with the differential mounting tabs on the front crossmember and re-install the 9/16" x 4-1/2" bolt through the skid plate, crossmember tabs, and differential. Secure using the supplied washer and nyloc nut. Do not tighten at this time.
- Attach the skid plate to the rear crossmember using the supplied 5/16" x 1" stainless allen bolts with washers in the threaded holes present in the crossmember. Do not tighten at this time.

17) FASTENER TIGHTENING SEQUENCE...

- Torque the following hardware in sequence:
 - All 5/8" hardware (154)
 - All 9/16" hardware (119)
 - Factory differential hardware (82)
 - 5/16" skid plate hardware (19)
- On each side, check for adequate clearance between the differential drive flanges and the factory lower control arm mounts. Also cycle the steering and check for adequate clearance between the centerlink and the differential housing.

18) FRONT DRIVESHAFT...

NOTE: If the vehicle is equipped with a gasoline engine, exhaust modifications are required for front driveshaft clearance. If necessary, remove the front driveshaft from the vehicle. The vehicle can be driven to an exhaust shop to have the necessary modifications performed once the lift installation is complete.

- Attach the front driveshaft to the differential according to the marks made during removal. Use the factory hardware and tighten (24).
- Reconnect the differential wiring and use the supplied vent hose extension to reconnect the differential vent hose.

19) KICKER BRACES...

- Remove the transfer case skid plate if equipped. Save all hardware for re-use.

- Lubricate and install the supplied bushings and sleeves in both ends of the kicker braces (#55-29-3480).
- Attach the kicker braces to the mounting tabs on the rear crossmember using the supplied 7/16" x 4" bolts, washers, and nyloc nuts. Do not tighten at this time.
- Attach the supplied kicker brace attachment brackets (#55-10-3370) to the other end of the kicker braces using the supplied 7/16" x 4" bolts, washers, and nyloc nuts. Do not tighten at this time.
- Swing the kicker brace assembly up against the transmission crossmember. Mark the location of the mounting holes to be drilled in the crossmember. Lower the kicker braces and drill at the marked locations using a 15/32" bit.
- Attach the kicker brace assembly to the transmission crossmember using the supplied 7/16" x 1-1/4" bolts, washers, and tab nuts.
- Tighten all of the 7/16" hardware (54).
- Notch the corner of the factory skid plate to clear the kicker brace bracket, then attach the skid plate to the transmission crossmember using the factory hardware and tighten (23).

20) KNUCKLE ASSEMBLY...

NOTE: Perform the following steps one side at a time.

- Place the factory knuckle assembly on a table with the lugs facing downward. Remove the three bolts securing the wheel bearing assembly to the knuckle and remove the knuckle. **Discard the factory dust shield.**
- Note that the ABS sensor on the hub assembly points upward when the knuckle is positioned as it would be installed on the truck. **Position the replacement knuckle (#66-01-3390 driver side and #66-02-3390 passenger side) on the hub assembly with the ABS sensor pointing forward when the knuckle is positioned as it would be installed on the vehicle (90 degrees from the original orientation).** Secure the hub assembly to the knuckle using the factory hardware and be sure to apply the supplied thread-locking compound. Tighten (133).

21) KNUCKLE INSTALLATION...

NOTE: Perform the following steps one side at a time.

- Attach the lower control arms to the front and rear crossmembers using the factory hardware. Do not tighten at this time.
- Line up the knuckle assembly with the upper and lower ball joints. Secure the knuckle using the factory hardware. Tighten the upper ball joint (37) and lower ball joint (94).

NOTE: The lower control arms will be tightened once the vehicle is on the ground with the suspension supporting the vehicles weight.

NOTE: Verify that the ABS sensor (with its related wiring) is pointing forward instead of up as it was stock.

22) CV AXLE SPACERS...

Turn the knuckle so that the tie rod boss is pointing outward. Install the CV axleshaft by first passing the end of the axleshaft in front of the differential and then sliding the axleshaft into the hub assembly. Secure the CV axleshaft at the hub using the factory nut and tighten (156). Reinstall the factory dust cap.

Position a CV axle spacer (#55-19-3320) between the differential flange and the flange on the CV axle. Line up the mounting holes and install the supplied 10mm x 70mm bolts with flat washers through the CV axle, spacer, and into the differential flange. Take precautions to avoid overtightening and stripping these bolts. Tighten (58).

DIAGRAM 4A - BRAKE HOSE AND ABS WIRE ROUTING, REAR VIEW.

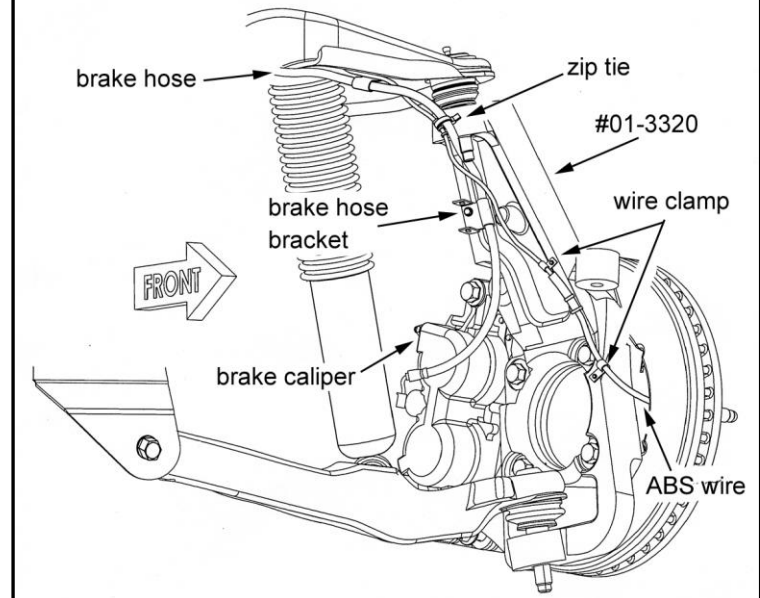

23) BRAKE CALIPERS...

Reinstall the brake rotors and attach the caliper brackets to the knuckle using the factory hardware along with the supplied thread-locking compound. Tighten (133).

[DIAGRAMS 4A and 4B] Verify that the hub assembly is oriented so that the ABS sensor is pointed toward the front of the vehicle. Route the ABS wire under the tie rod mounting boss as shown. Position the supplied clamps on the wire and secure the clamps to the pre-drilled holes in the backside of the knuckle using the supplied 1/4" x 1/2" self-tapping bolts. Tighten (76 in-lb).

DIAGRAM 4B - BRAKE HOSE AND ABS ROUTING.

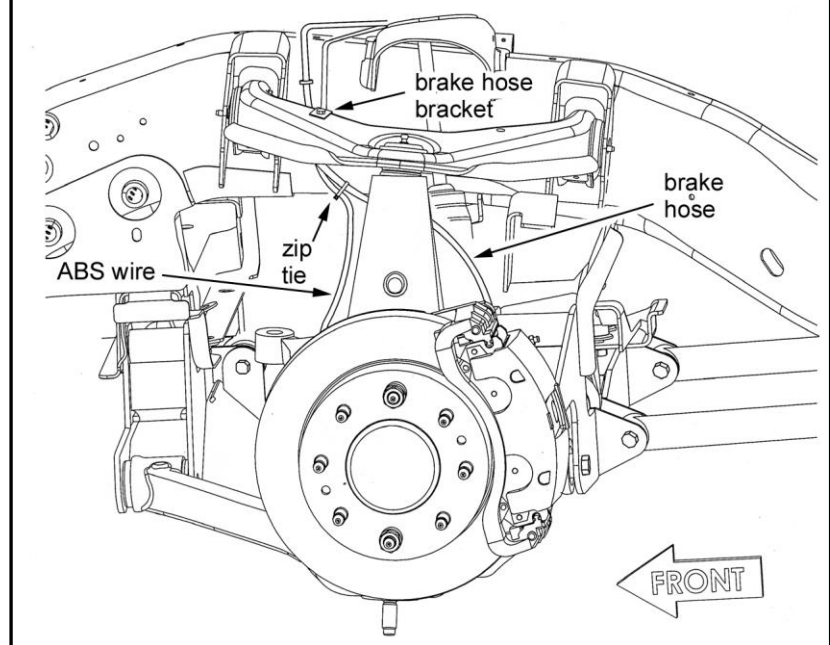

Re-attach the factory brake hose bracket to the upper control arm if it was unbolted during disassembly. Also attach the other bracket to the backside of the knuckle as shown. Be sure to follow the brake routing exactly as shown.

- Reconnect the ABS wire to the wiring at the frame and attach the wire to the brake hose as shown in the Diagrams.

24) SHOCK ABSORBERS...

- Remove the factory lower shock brackets from the lower control arms. Attach the supplied lower shock brackets (#55-18-3290) using the factory hardware and tighten (23).
- Install the supplied bushings and sleeves in the shock absorbers. Attach the lower end of the shocks to the "18" brackets using the factory hardware. Attach the stem end of the front shocks to the factory mount using the supplied bushings, washers, and fine-thread nut.
- Tighten the lower end (59) and upper end of the shock until the bushing swells slightly.

25) FRONT ANTI-SWAY BAR...

- Attach the front anti-sway bar drop brackets (#55-09-3320 driver side and #55-08-3320 passenger side) to the bar's factory location on the frame using the factory hardware. Note that the brackets have offset mounting faces; the lower end of the brackets should be offset toward the front of the vehicle. Do not tighten the hardware at this time.
- Attach the anti-sway bar to the "08" and "09" brackets using the supplied 3/8" x 1-1/4" bolts, washers, and nuts.
- Tighten the factory hardware (23) and the 3/8" hardware (23).
- Attach the factory anti-sway bar end links to the lower control arms and anti-sway bar using the factory bushings and hardware. Tighten (24).

29) TORSION BAR DROP BRACKETS...

- [DIAGRAM 5] Following the diagram, scribe a straight line from the center of the factory torsion bar crossmember brackets (located near the top of the frame) to the bottom of the frame. Line up the center hole on the side of the Superlift torsion bar drop bracket (55-15-3290 driver side and 55-16-3290 passenger side) with this line and firmly clamp the bracket into place.

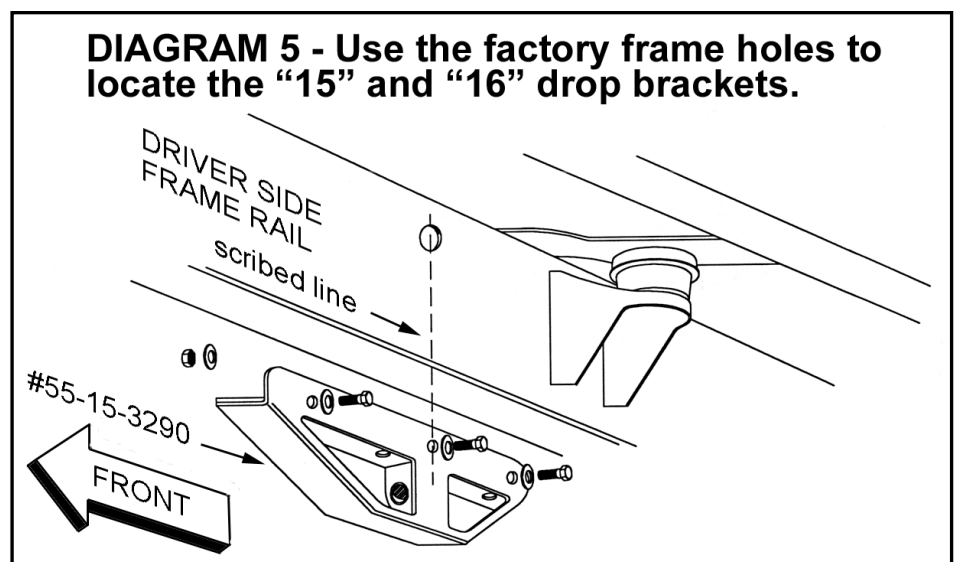

- Locate and install the appropriate bushings and sleeves (lubricate the outside of the sleeves with grease) for the "15" and "16" brackets.

- Scribe marks on the frame for all the holes (six for each bracket) needed to mount the "15" and "16" brackets. Remove the brackets and use a 15/32" bit to drill the holes. Clean up any burrs using a file.
- Slide the torsion bars into the lower control arms. Make sure the bars are properly indexed according to the marks made during disassembly.
- Mount and tighten the "15" bracket using the provided 7/16" x 1-1/4" bolts and related hardware (37 lb-ft).
- [DIAGRAM 6] Loosely install the outside bolts for the "16" bracket and slide the torsion bar crossmember into position as shown using the factory bolts. Install the remaining 7/16" bolts and tighten (37 lb-ft).

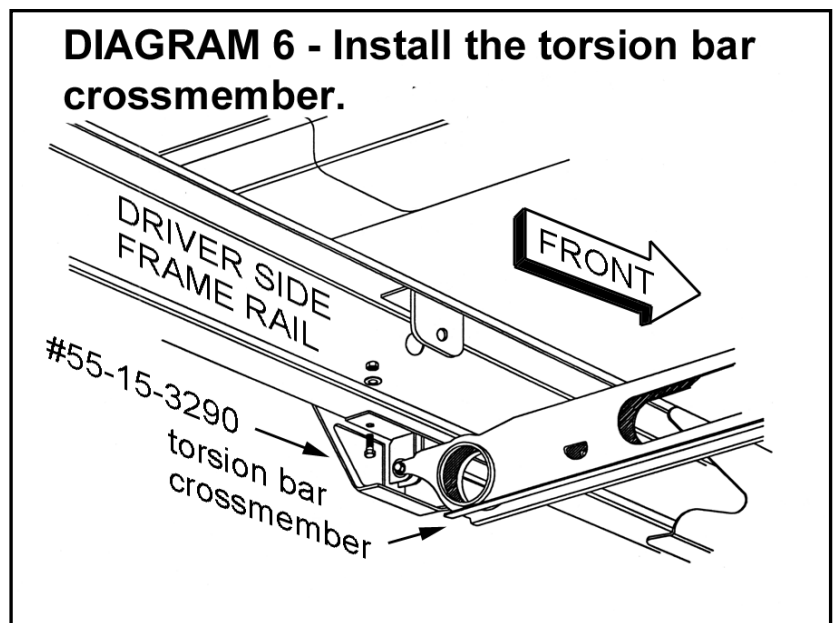

27) LOADING THE TORSION BARS...

- Hold the adjuster arms inside the crossmember and slide each torsion bar back into place. Make sure the bars are properly indexed with the adjusters by following the marks made during disassembly.
- Load the torsion bar using the special tool and reinstall the factory adjusting bolt and nut block. Leave about half of the bolts threads visible below the nut block and unload the tool. Final ride height adjustments will be made once the vehicle is on the ground.

28) TIRES / WHEELS...

- [DIAGRAM 7] Tighten the lug nuts (145 lb-ft) in the sequence shown.

WARNING: When the tires / wheels are installed, always check for and remove any corrosion, dirt, or foreign material on the wheel mounting surface, or anything that contacts the wheel mounting surface (hub, rotor, etc.). Installing wheels without the proper metal-to-metal contact at the wheel mounting surfaces can cause the lug nuts to loosen and the wheel to come off while the vehicle is in motion.

WARNING: Retighten lug nuts at 500 miles after any wheel change, or anytime the lug nuts are loosened. Failure to do so could cause wheels to come off while vehicle is in motion.

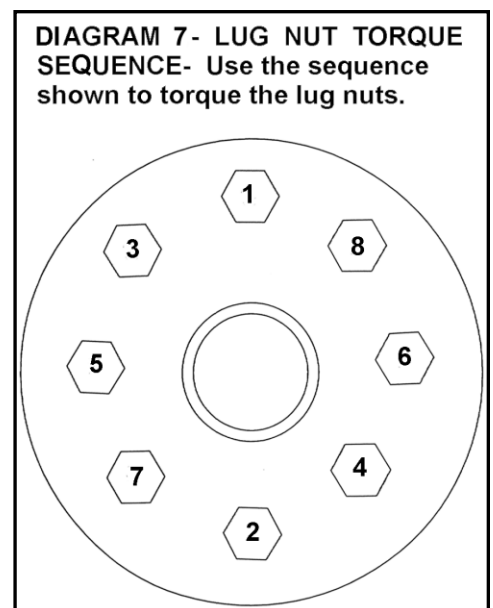

29) CLEARANCE CHECK...

- With the vehicle still on jack stands, and the suspension “hanging” at full extension travel, cycle steering lock-to-lock and check all components for proper operation and clearances. Pay special attention to the clearance between the tires / wheels and brake hoses, wiring, etc.
- Lower vehicle to the floor.

REAR PROCEDURE

30) PREPARE VEHICLE...

- Raise rear of vehicle with a floor jack positioned under the rear axle. Place jack stands under the frame rails, a few inches in front of the rear springs’ front hangers. Ease the jack down until the frame is resting on the stands. Keep a slight load on the jack. Chock front tires to prevent accidental movement.
- Remove the tires, U-bolts, and shocks.

31) LIFT BLOCKS AND U-BOLTS...

- Lower the axle by carefully easing down the jack. **Do not overextend the brake lines and axle vent hoses.**

NOTE: Spring perches are prone to collapse or warp where the leaf springs or blocks seat on the axle, especially towards the ends. Without a perfectly flat mounting surface, the block may fail and “roll” out off of the perches. If the perches are not flat, fix them by welding on a piece of ¼” plate (or something similar) or replace the perches completely.

- Make sure the top of the spring perches and the bottom of the springs are clean and free of any debris. Position the Superlift blocks in between the leaf springs and the factory blocks.

WARNING: The vehicle is equipped with short cast spacer blocks located between the leaf springs and the axlehousing. These factory blocks must be retained because they seat properly against the axle mounts; the Superlift spacer blocks do not. When using Superlift blocks, install them on top of the factory blocks.

- Install the supplied U-bolts, then torque the bolts in an “X” pattern to the following specifications:

SUPERLIFT U-BOLT TORQUE GUIDE

NOTE: Torque specifications apply to Superlift U-bolts only

DESCRIPTION	PLATED (lb-ft)	PLAIN FINISH (lb-ft)
½” dia., up to 13” long	57	92
9/16” dia., up to 13 ½” long	82	131
9/16 dia., 13 ½” and longer	106	185

5/8" dia., up to 14 1/2" long	112	181
5/8" dia., 14 1/2" and longer	145	256

32) CARRIER BEARING SPACER...

The carrier bearing is part of the rear driveshaft assembly. It supports the rear driveshaft and is attached to a frame crossmember between the transmission and the rear axle. The carrier bearing spacer (55-30-3290) installs between the bearing and the crossmember.

- Determine the amount of drop needed. The carrier bearing spacer (55-09-3290) is essentially a rectangular piece of box steel. One side of the "box" will space the bearing down 1", while the other will space the bearing down 1-1/2". It can be installed either way. The correct way to install the spacer depends on the wheelbase:
 - For long-bed crew cab trucks, position the spacer so that it lowers the bearing 1-1/2".
 - For most other applications, position the spacer so that it lowers the bearing 1".
- Unbolt the carrier bearing from the frame crossmember.
- Position the "09" spacer between the bearing and the crossmember with the correct amount of drop for the wheelbase.
- Attach the bearing and spacer assembly to the crossmember using the supplied 7/16" x 1-1/4" bolts, washers, and nyloc nuts. Tighten (50).

33) COMPRESSION TRAVEL STOPS...

- Remove the factory rear compression travel stops and install the extension brackets (55-19-3290) in the same location with the supplied 7/16" x 1-1/4" bolts and related hardware. Attach the factory compression travel stops to the "19" brackets and tighten (11).

34) BRAKE HOSE RELOCATION...

- Locate the factory rear brake hose bracket mounted to the top of the driver side frame rail. Unbolt the bracket from the frame.
- Carefully bend the steel brake line to reach the new bracket location without touching or interfering with other components. The bracket should be directly below the bracket's original mounting location.
- [DIAGRAM 8] Using the bracket as a template, scribe two marks for new mounting holes at the bottom of the frame. Remove the bracket and drill two 17/64" holes. Clean up any burrs with a file.

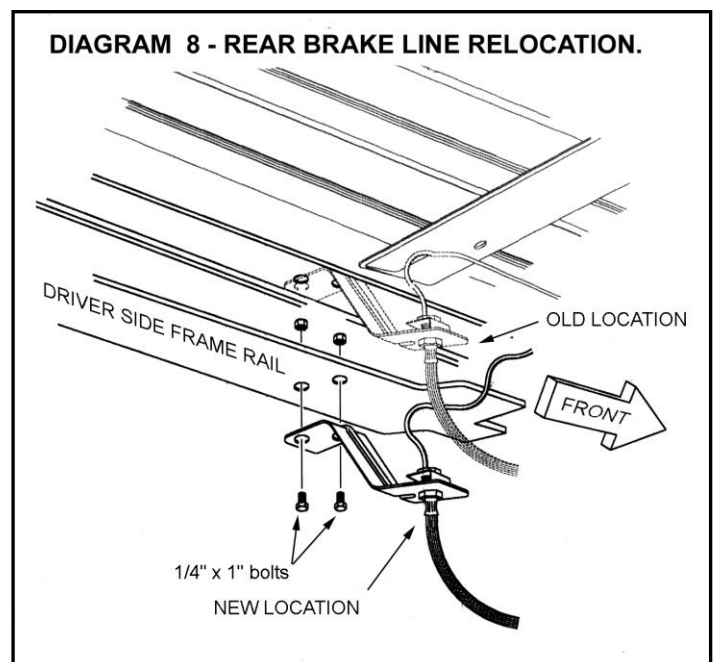

- Remount the factory brake bracket to the bottom of the frame using the supplied 1/4" x 1" bolts and nyloc nuts.
 - Check for adequate length of the rear brake hose in the new location. On certain applications, a little more length is needed. If so, bend the factory bracket down slightly to gain the necessary slack in the hose.
- 35) EMERGENCY BRAKE CABLES...**
- There are two brackets constructed of heavy-gauge wire attached to the driver side frame rail near the rear tire that hold the emergency brake cables. Remove and discard the rearward-most bracket (closest to the back bumper).
 - Remove the other bracket from the frame and attach the supplied emergency brake cable drop bracket (55-26-3280) to the frame in its place using the factory hardware. Now, attach the factory bracket to the "26" bracket using the supplied 1/4" x 1" bolt, washers, and nyloc nut (11).
 - On the driver side lower shock mount there is a clamp that secures the driver side emergency brake cable to the axle. Unbolt the clamp, remove it from the cable, and discard. Reinstall the bolt securing the brake line and tighten to factory specifications.
 - Disconnect the driver side emergency brake cable from the caliper. Route the cable over the axle tube and then re-attach it to the caliper. Re-attach to the caliper and check for proper operation.
 - Install the tires and wheels per step 28 and lower the vehicle to the floor.

FINAL PROCEDURES

36) ADJUSTING FRONT RIDE HEIGHT...

- Manually bounce the front and rear of the vehicle to normalize the torsion bars and leaf springs.
- On each side, fully tighten the LCA-to-crossmember bolts (107).
- [DIAGRAM 9] Position the vehicle on a level surface. Measure from the LCA front pivot bolt center down to the floor. Record this as Measurement "A".
- Now measure from the inside edge of the knuckle (at the lower ball joint boss) down to the floor. Record this as Measurement "B".

DIAGRAM 9 - Ride height adjustment.

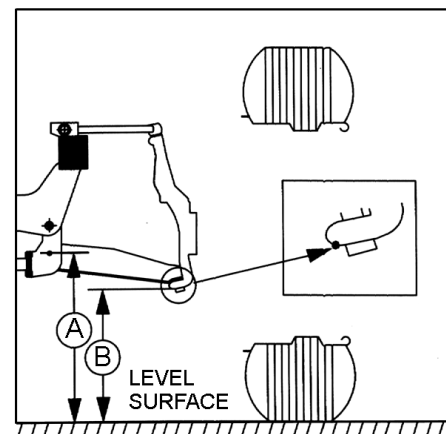

A = CENTERLINE OF LCA PIVOT BOLT - TO - FLOOR
 B = EDGE OF KNUCKLE - TO - FLOOR
 A - B = RIDE HEIGHT

Subtract Measurement “B” from “A” for the ride height figure. Minimum ride height is 4.3”; maximum is 4.8”. Ideal ride height is 4.7”. Raise height by tightening the torsion bar adjusting bolt; lower height by loosening the bolt. Adjust height 3/8” to 1/2” above the final desired ride height, since the bars will settle slightly after the vehicle is driven.

NOTE: Exceeding the stated minimum or maximum heights will cause the suspension to continually “top out” or “bottom out”. This results in a harsh ride, accelerated suspension component wear, and possibly component failure.

37) FINAL CLEARANCE and TORQUE CHECK...

NOTE: If the optional stainless steel front brush guard has been purchased, install now per separate instructions.

- With vehicle on floor, cycle steering lock-to-lock and inspect the tires / wheels, and the steering, suspension, and brake systems for proper operation, tightness, and adequate clearance.
- Reconnect the battery.

38) Activate four wheel drive system and check front hubs for engagement

39) HEADLIGHTS...

- Readjust headlights to proper setting.

40) SUPERLIFT WARNING DECAL...

- Install the WARNING TO DRIVER decal on the inside of the windshield, or on the dash, within driver’s view. Refer to the “NOTICE TO DEALER AND VEHICLE OWNER” section below.

41) ALIGNMENT...

Realign vehicle to factory specifications. Record the ride height measurement at time of alignment. If, in the future the torsion bars settle excessively, alignment can be restored by adjusting-up the bars to their original ride height.

IMPORTANT PRODUCT USE INFORMATION

As a general rule, the taller a vehicle is, the easier it will roll over. Offset, as much as possible, what is lost in roll over resistance by increasing tire track width. In other words, go “wide” as you go “tall”. Many sportsmen remove their mud tires after winter / hunting season and install ones more appropriate for street driving; always use as wide a tire and wheel combination as possible to enhance vehicle stability.

We strongly recommend, because of roll over possibility, that the vehicle be equipped with a functional roll bar and cage system. Seat belts and shoulder harnesses should be worn at all times. Avoid situations where a side rollover may occur.

Generally, braking performances and capabilities are decreased when significantly larger / heavier tires and wheels are used. Take this into consideration while driving.

Do not add, alter, or fabricate any factory or aftermarket parts to increase vehicle height over the intended height of the Superlift product purchased. Mixing component brands is not recommended.

Most states have some type of law limiting vehicle height. The amount of lift allowed, and how the lift may be achieved, varies greatly. Several states offer exemptions for farm or commercially registered vehicles. It is the owner's responsibility to check state and local laws to ensure that their vehicle will be in compliance.

Superlift makes no claims regarding lifting devices and excludes any and all implied claims. Superlift will not be responsible for any altered product or any improper installation or use of our products.

We will be happy to answer any questions concerning the design, function, and correct use of our products.

IMPORTANT MAINTENANCE INFORMATION

It is the ultimate buyer's responsibility to have all bolts / nuts checked for tightness after the first 100 miles and then every 1000 miles. The steering, suspension and driveline systems, along with wheel alignment should be inspected by a qualified professional mechanic at least every 3000 miles.

NOTICE TO DEALER AND VEHICLE OWNER

Any vehicle equipped with a Superlift lifting device must have the enclosed "Warning to Driver" decal installed on the inside of the windshield or on the vehicle's dash, within driver's view. The "Warning to Driver" decal is to act as a constant safety reminder for whoever may be operating the vehicle. The WARRANTY IS VOID unless this decal is in place. **INSTALLING DEALER...** It is your responsibility to install warning decal and forward these installation instructions to the vehicle owner for review of warnings, product use and maintenance information. Replacement warning decals are available free upon request. These instructions are to be kept with the vehicle registration papers and owners manual for the service life of the vehicle.

SUPERLIFT LIMITED LIFETIME WARRANTY

Suspension products bearing the Superlift (LKI Ent.) name are warranted for as long as the original purchaser owns the vehicle that the LKI product was originally installed on. This warranty is non-transferable. Warranty covers only the product, no labor, time loss, or freight incurred. Any product that has been abused, altered, incorrectly installed, or used in competition is not covered. Product finish, spring bushings, Polyurethane products, and normal wear is not covered. The LKI product is subject to replacement or repair. No other warranties are expressed or implied. An authorized Superlift dealer must inspect the part in question and confirm that the "Warning to Driver" decal is properly displayed. A copy of the sales invoice is required for warranty consideration.

SUPERLIFT SUSPENSION SYSTEMS

300 Huey Lenard Loop Rd.
West Monroe, Louisiana 71292
Phone: (318) 397-3000
Sales / Tech: 1-800-551-4955
FAX: (318) 397-3040
www.superlift.com