

Damaged or missing parts? Call 877-878-9336 Mon - Fri 8 am - 5 pm CT
Parts will be shipped to you factory direct. Do not return kit to place of purchase.

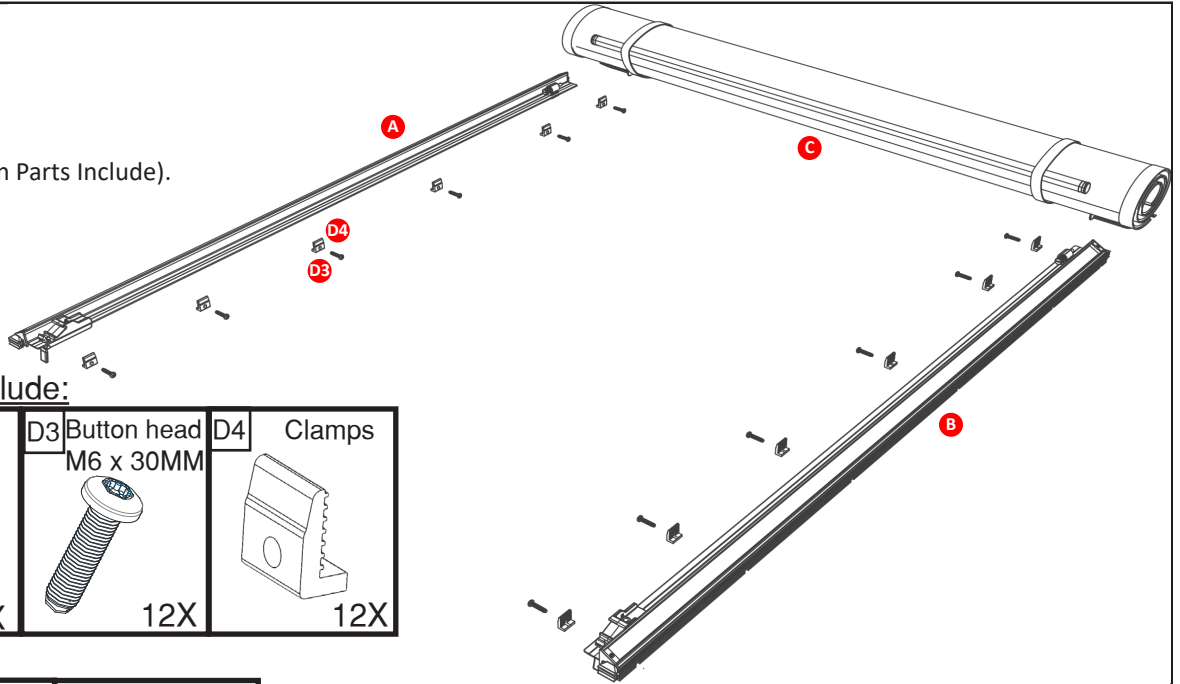

READ INSTRUCTIONS - Failure to assemble cover properly will void warranty. To view install video visit truxedo.com/lopro

**PARTS INCLUDED
IN YOUR KIT:**



- A** Driver side cover rail
- B** Passenger side cover rail
- C** Roll cover
- D** Hardware Bag (see Installation Parts Include).

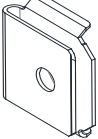
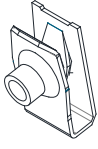

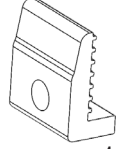
D Installation Parts Include:

D1 Drill Guide  2X	D2 J-Nut  10X	D3 Button head M6 x 30MM  12X	D4 Clamps  12X
--	--	---	---

Tools Required:

T30 Torx 	Drill 	7.00 mm (9/32") drill bit 
--	---	--

1 The serial number for the cover is located here.

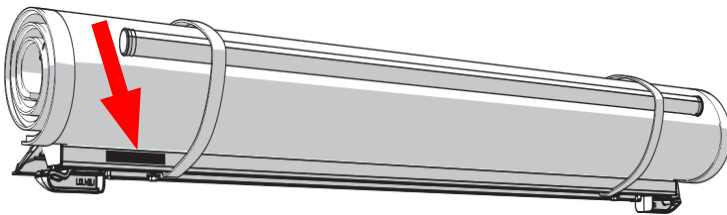

For future reference, write it here: _____

2 It is important that all areas where the bed cover mounts are clean and free of debris prior to installing.



3 If the truck is equipped with factory bed caps, you will need to install the bulkhead seal supplied in the shipping box. If the truck is equipped with aftermarket bed caps, we recommend that you call customer service at 877-878-9336 to purchase bulkhead seal.

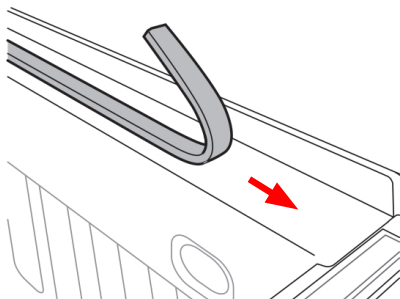

For steps 4 thru 5 use hardware D1 and D2. Drill and 7MM drill bit will also be used in these steps.

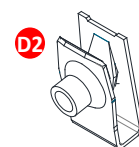
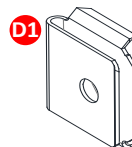

Note: In fig. 1, 2 and 3 the J-nuts are shown inserted behind the bed caps.

TOOLS REQUIRED:



4 U-nut installation, item D2. Insert the U-nuts by prying the plastic truck bed cap away from the truck bed while sliding the U-nut into the bed wall opening (fig. 1), making sure that the U-nut is aligned with the bed rail hole as shown in fig. 2. Repeat for the passenger side.

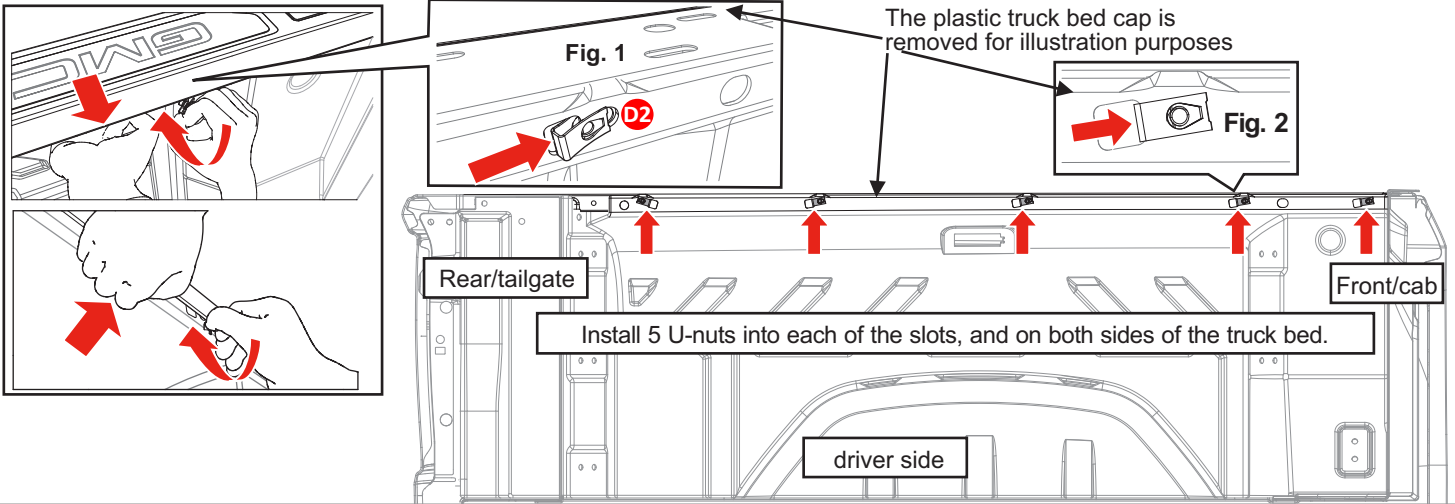

5 Drill mounting holes. Use drill guide, item D1. Slide the hole drill guide onto the edge of the truck's plastic bed cap and in between the cap and the bed (fig. 3). Align the hole drill guide so that the back of the guide fits into the hole of the U-nut (fig. 4). Drill a 7mm, (9/32") hole through the truck plastic bed cap using the hole drill guide (fig. 5). The back of the hole drill guide will prevent the drill from hitting the truck bed. Repeat this for every U-nut location on both sides of the truck bed.

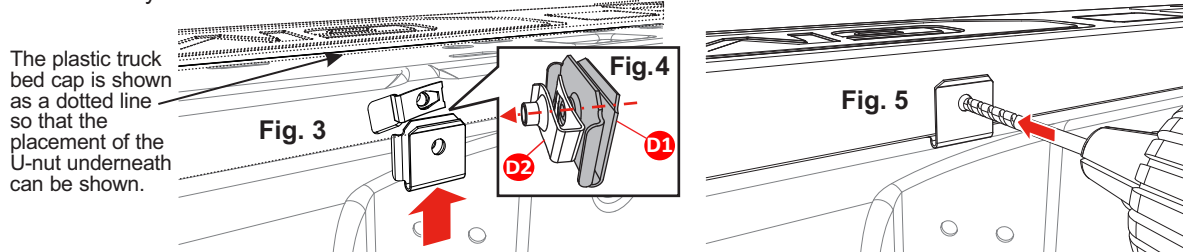

Drill mounting holes, continued

The truck bed cap sheet metal already has a threaded hole included (fig. 6). A hole must be drilled through the truck's plastic bed cap to access the threaded hole for mounting. Slide the hole drill guide onto the edge of the truck's plastic bed cap and in between the cap and the bed. Align the hole drill guide so that the back of the hole guide aligns with the threaded hole. Drill a 7mm, (9/32") hole through the truck plastic bed cap using the hole drill guide. Repeat this on both sides of the truck bed.

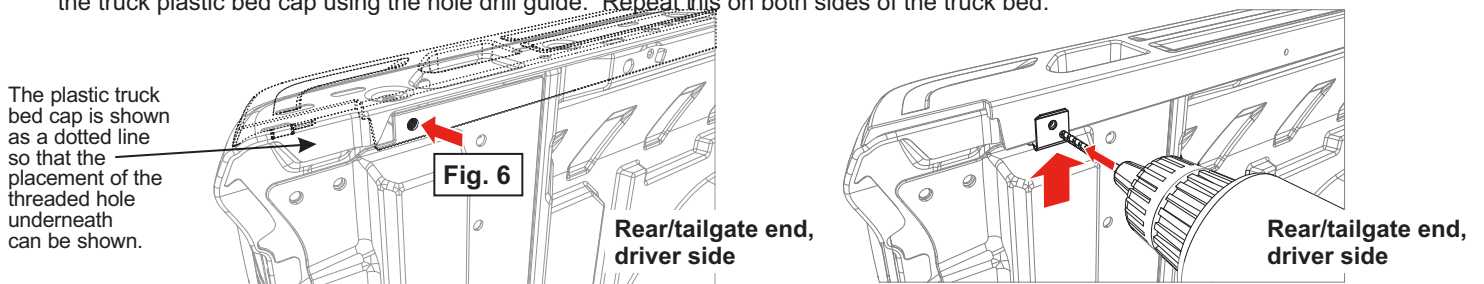

6 Install driver and passenger rail. The assistance of a second person is recommended but not required for step 7 thru 8.

To install the rails, hardware D3 and D4 will be used. Proceed to step 7 for hardware placement and order of installation.

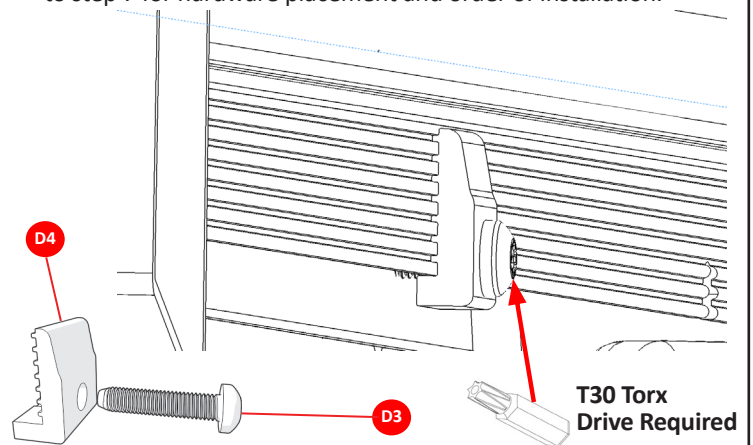
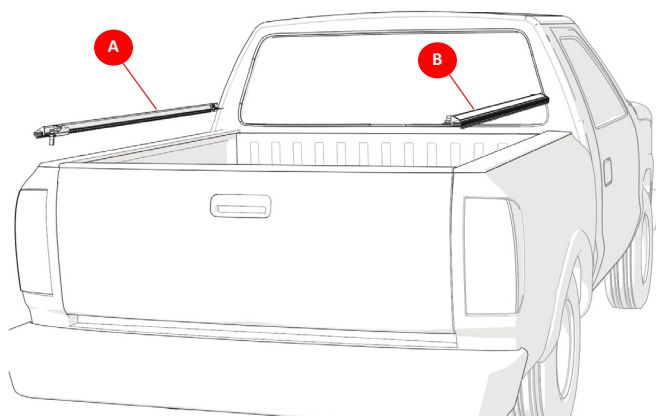

7 Clamp Installation. Insert the screw through the clamp, through the cutout in the rail and into the installed U-nut, do not tighten fully. Start with the front/cab hole, (fig.7) and the rear/tailgate hole to hold the rail in place.

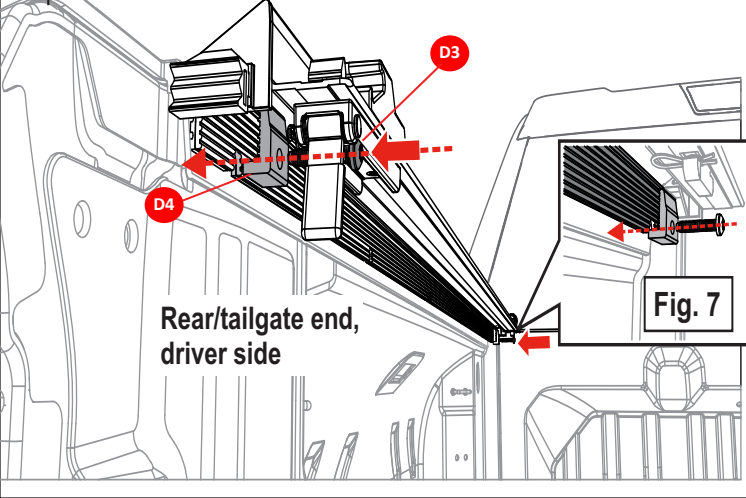

8 Install the remaining four middle clamps. Starting with rear/tailgate tighten the screws. Push the rail into the plastic bed cap when tightening each screw to help the rail seal against the bed cap. Tighten the remaining screws in order to the front/cab. Repeat the installation on the other side.

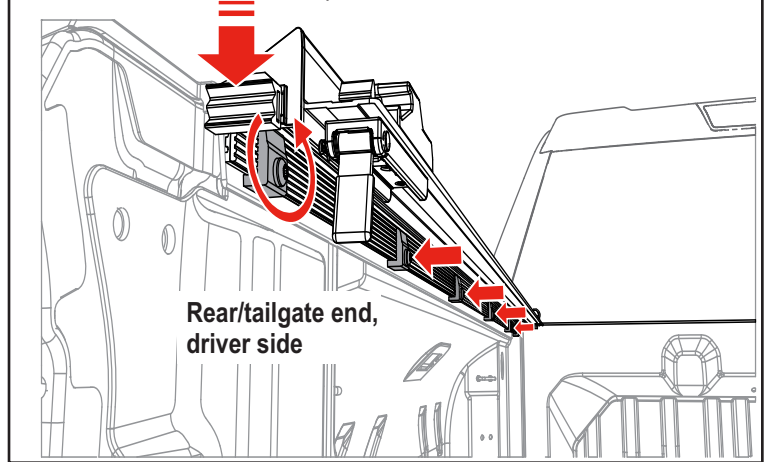

9 Once both rails (A & B) have been correctly installed, place the cover (C) on the side rails towards front of the truck bed (near the cab). The front header seal is designed to help shed water and should be sitting on top of the bulkhead.

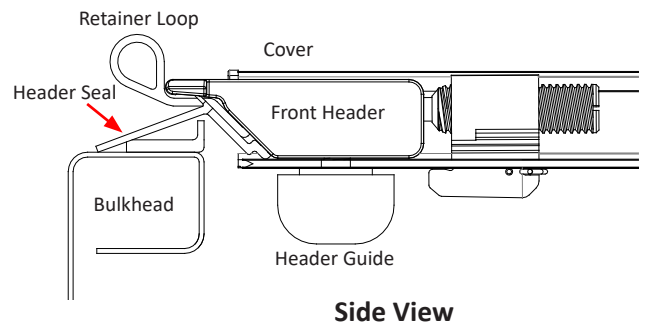
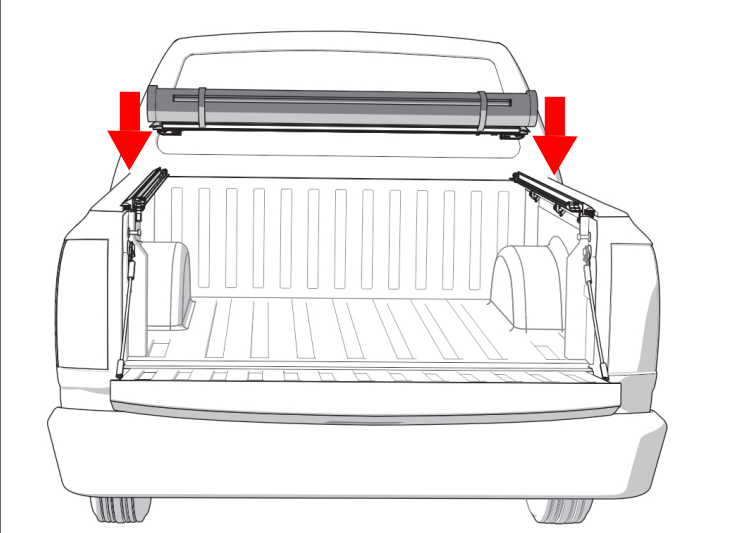

10 Slide right and left header guides into the locked position. A clicking sound will indicate a secure attachment. Your tonneau cover has been successfully installed.

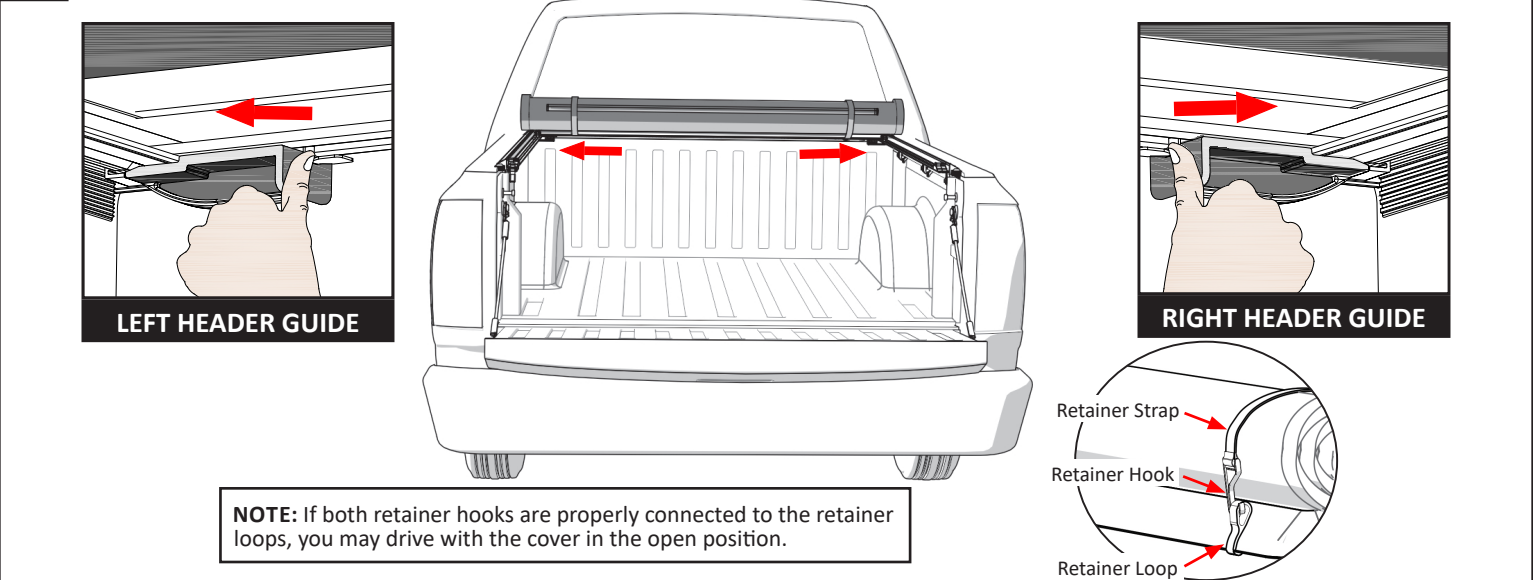

COVER IN CLOSED POSITION

- 11** To drive with the cover in the closed position, disengage the retainer hooks from the retainer loops and unroll the cover towards the tailgate.

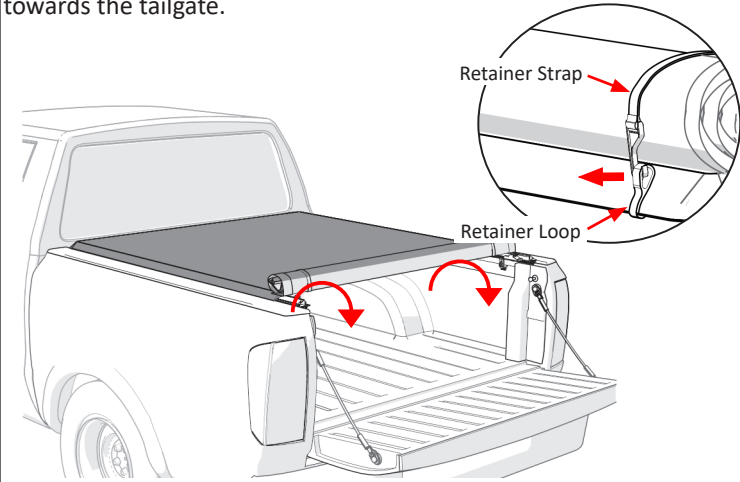

- 12** Place the front header into the header stops which are located on both side rails. Rotate the front header downwards until you feel the cover latch in place.

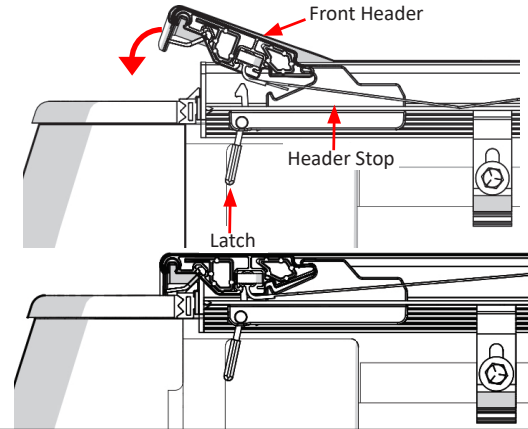

NOTE: We recommend closing the tailgate first and then closing the cover.

COVER IN CLOSED POSITION (CONT'D)

- 13** When closing the cover a clicking sound will indicate a securely attached cover.

NOTE: If tailgate has a key lock, cover is secured until tailgate is unlocked and opened.

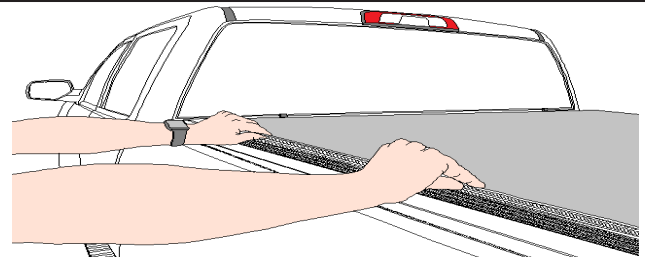
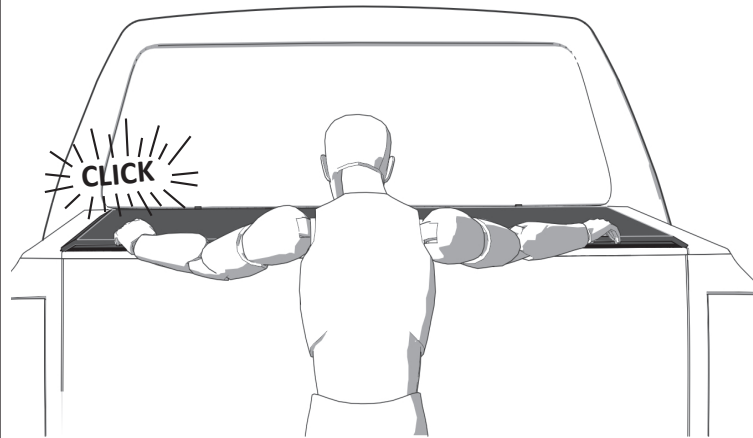

We recommend securing the hook and loop fastener along the entire length of both side rails before driving the vehicle. Simply pull the fabric over the hook.

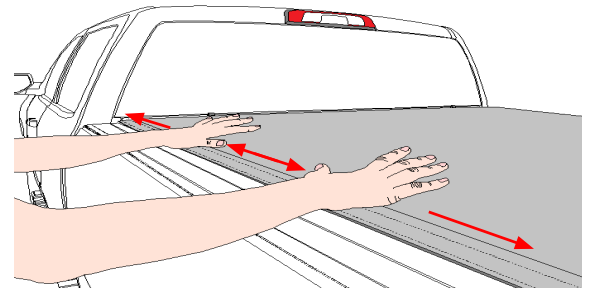

Next, run your hands down both sides of the cover. This will prevent wind from lifting the cover and causing possible damage.

You are ready to drive with the cover in the closed position.

COVER IN THE OPEN POSITION

- 14** To drive with cover in the open position, pull the latch towards you to release the cover (located on driver side rail). Roll the cover toward the cab of the truck, making sure that both sides roll evenly. Secure the cover by placing both retainer hooks into the retainer loops. **You are ready to drive with the cover in the open position.**

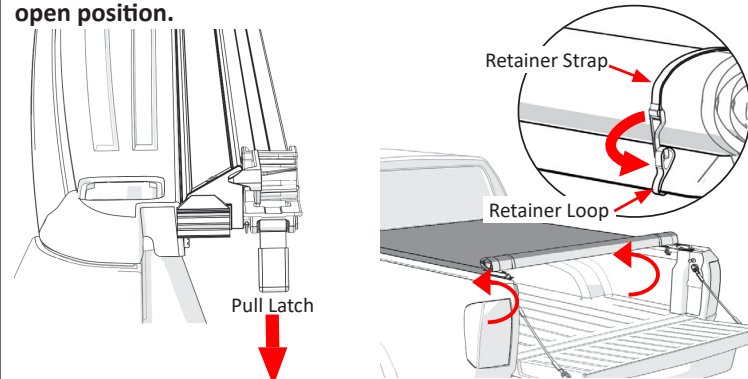

REMOVING THE COVER

- 15** To remove the cover from the side rails, push up on the retainer tab and then slide the header guide away from the side rail. Do this on both the driver and passenger side. Carefully lift the cover off the side rails.

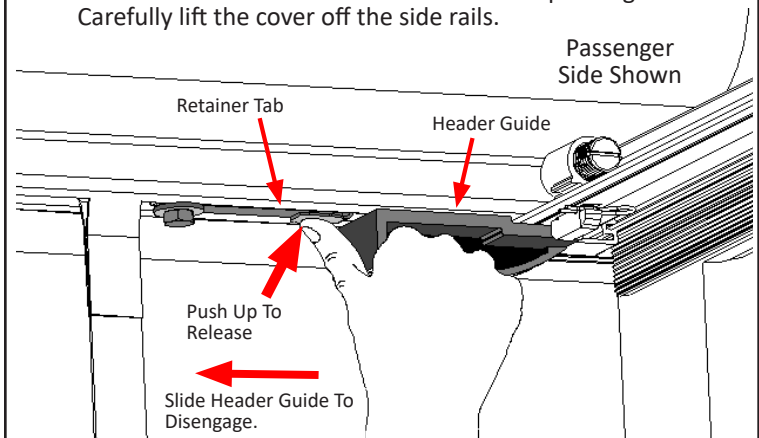

16 Automatic tension control compensates for material expansion & contraction caused by temperature changes. Set tension during **warmest part of day**. With cover closed, release hook and loop fastener from both side rails near cab. Check compression of both spring plungers against the front header per Detail C. Roll cover open and make adjustments. Close cover and re-check adjustment. Repeat until satisfactory tension has been achieved.

DETAIL C

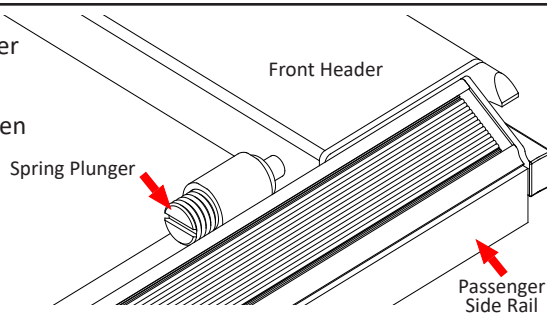
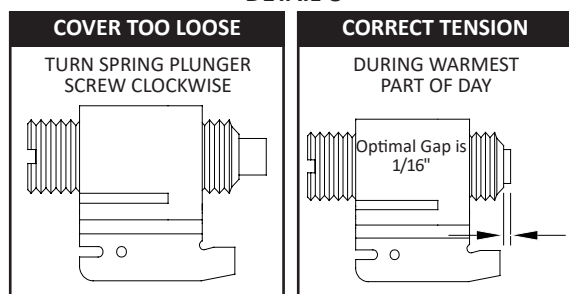

NOTE: Adjust tension in small increments. Slight adjustments will gain significant results.

NOTE: Check cover tension after installation, seasonally, and after extreme temperature changes.

WARRANTY DURATION

TruXedo®, Inc. ("TruXedo") offers a LIFETIME warranty on Lo Pro, Deuce and Pro X15. Warranty is limited to original purchaser of truck bed cover and is nontransferable. The warranty registration must be on file and/or proof of original purchase (detailed and dated receipt) required for warranty service.

WARRANTY CONDITIONS

This warranty is against defective materials or workmanship. The warranty is void if the product has been damaged by accident, unreasonable use, neglect, improper service/installation/removal, modifications, normal wear and tear or other causes not arising out of defective materials or workmanship. Consequential and incidental damages are not covered under this warranty. TruXedo's obligation under this warranty is limited to repairing or at its option, replacing any part that is returned, transportation prepaid, to Yankton, South Dakota, if the product is, in our judgement, defective. All materials must be accompanied by an RMA (Returned Material Authorization) number requested by and authorized in advance of returning the materials. TruXedo shall not be liable or responsible to supply or pay labor to replace any part found defective, nor shall it be liable for any damages of any kind or nature to person, product, or property.

- Please register the warranty online at truxedo.com
- Direct all warranty claims to TruXedo at **877-878-9336**
- For available installation videos, visit the TruXedo **YouTube** channel

The Following Conditions will Void Warranty:

- **Wind Whip Damage** – The cover must be secured at all points when the vehicle is in motion. An unsecured cover will flap, resulting in damage to the vinyl fabric.
- **Improper Cleaning** – It is recommended to use the tested and approved TruXedo PROTEX or clean with soap and water only. Do not use vinyl conditioners (i.e. Armor All®) because they will shrink the vinyl.
- **Overloading of cargo** – Cargo should not contact the tarp at any point. Protrusions in the tarp will stress the vinyl fabric. Cargo may also shift while traveling causing it to press against the vinyl fabric and damage it.

OWNER/USER RESPONSIBILITIES

It is the responsibility of the owner/user to read this manual and comply with the operating procedures. The owner/user is also responsible for inspecting the TruXedo cover and for having parts repaired or replaced when worn or damaged. Failure to follow safety instructions and warning labels could result in failure of your cover system and/or personal injury.

IMPORTANT OPERATING TIPS

- DO NOT roll cover into rear cab window. DO NOT stow against cab.
- After closing the cover, operator must secure hook and loop by running your hand down the driver and passenger side rails, pushing down on the cover material.
- If rails are tipping, clamps can be adjusted to level the side rails to ensure proper fit.
- For optimal fuel economy, it is recommended to operate the vehicle with the cover rolled closed and latched.
- The tonneau cover must be free of foreign material including snow and ice before rolling open or closed.



SAFETY INSTRUCTIONS

- DO NOT place objects on or against cover or framework.
- DO NOT tie cargo to truck bed cover framework.
- DO NOT attempt to drive with the cover in the partially open position.
- DO NOT operate vehicle with objects on top of the cover.
- NEVER allow children or pets to occupy pickup box while cover is closed.
- Cover is not airtight. Special care is required to keep cargo clean and dry.
- Tonneau covers won't prevent theft of contents inside truck box.
- The cover assembly (tarp) must be rolled fully open and secured with retainer straps when towing vehicle backwards.
- If the cover is going to be rolled open for an extended amount of time, periodically re-roll the cover and secure the retainer straps to ensure the cover doesn't rest against the cab of the truck.
- A fully rolled cover in the open position must always be secured with retainer straps.

TROUBLESHOOTING TIPS

- **WRINKLES ON THE VINYL FABRIC AFTER ROLLING COVER CLOSED**
Pull the vinyl fabric taut from each side. For best results, the help of a second person pulling on the opposite side is preferable
- **SAGGING VINYL FABRIC BETWEEN THE CROSS BOWS**
Adjustment to automatic tension control may be required. See Step 16.
- **WIND LIFTS UP THE EDGE OF THE VINYL FABRIC**
Make sure to engage hook and loop on driver and passenger side rails after closing the cover. This may need to be done periodically when taking long trips.
- **VINYL FABRIC FLUTTERS EXCESSIVELY WHEN DRIVING**
 - Check cover tension, refer to Step 16.
 - Make sure hook and loop fasteners are set. See Step 13.
- **SNOW AND ICE ACCUMULATION ON THE VINYL FABRIC**
 - Use broom or brush to remove loose snow and ice. DO NOT use sharp or pointed tools to remove snow and ice.
 - Direct sunlight will help melt snow and ice off the vinyl fabric.
- **TONNEAU COVER WILL NOT LATCH**
 - Check side rails to make sure they are level. See Step 7 and 8.
 - Make sure the header seal is not caught between side rails & header.
 - Check the position of side rails on the pickup box. They may be positioned too low. See Step 7 and 8.
 - Make sure the cover has proper tension. See Step 16.
- **VINYL FABRIC IS TOO TIGHT OR TOO LOOSE**
See Step 16 to adjust tension.
- **VINYL FABRIC HAS SHIFTED TOO FAR TO ONE SIDE**
Unlatch the cover at the tailgate, release the hook and loop along both sides, go to the shorter side of the tarp and tug. The vinyl fabric will slide in the aluminum headers. Pull on the shorter side until the tarp appears centered on the whole system. Latch cover and secure the hook and loop down both sides. Repeat if more adjustment is needed.

COVER CARE AND MAINTENANCE

- It is recommended to use the tested and approved TruXedo PROTEX or clean with soap and water only. Do not use vinyl conditioners (i.e. Armor All®) because they will shrink the vinyl.
- It is recommended that you periodically check that the cover is securely attached to your truck bed. Inspect the clamps and front header guide slides to ensure they were properly installed and have not come loose during operation.
- It is recommended that you periodically inspect and service the rear latch closure. Clean away any excess dirt or grime.
- Covers that are used frequently or are subject to vibrations and impacts from rough roadways may require adjustment.

FAQ

- **WHY IS THERE A HOLE PUNCHED AT THE REAR OF THE PASSENGER SIDE RAIL OF THE TRUXEDO LO PRO, DEUCE AND PRO X15 BUT NO LATCH?**
All side rails are punched identically to keep them uniform, to ensure manufacturing efficiency and to reduce tooling costs. By doing this, TruXedo can build and ship more covers while maintaining competitively priced products of the highest quality.
- **WHY IS MY COVER HOLDING WATER AFTER IT RAINS?**
Water pooling on the cover is normal because our cross bows are not arched. Since they are designed to sit flat some water may accumulate on the top of the cover. Once you drive your truck, the water will shed from the cover. Make sure to retighten the hook and loop fasteners along the length of the bed.



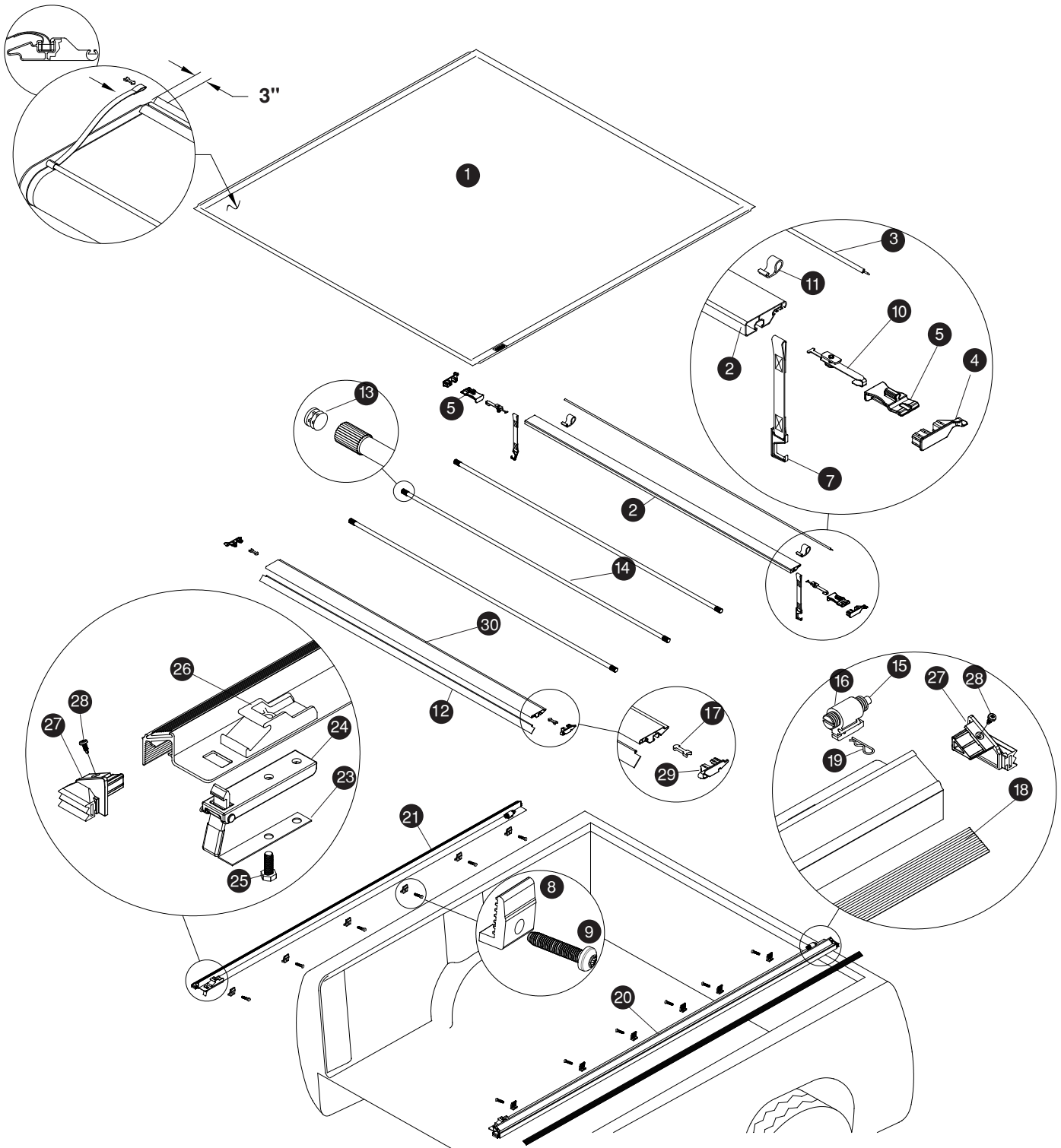

TRUXEDO® LO PRO REPLACEMENT PARTS

- | | | | | | | | | |
|----|---|--|----|---------|------------------------------|----|---------|---|
| 1 | * | TruXedo® Lo Pro Replacement Cover | 11 | 1705192 | Extruded Retainer Loop | 23 | 1114773 | Flat Spring, 5/8" x 3 7/8" |
| 2 | * | Black Front Header | 12 | 1118404 | Header Seal Rear | 24 | 1704213 | Latch Assembled |
| 3 | | 1118404 Header Seal Front | 13 | 1705052 | End Plug, 1" OD | 25 | 1702926 | Cap Screw, 5/16" x 7/8" |
| 4 | | 1117540 Front Header 08 End Plugs (Set of Two) | 14 | * | Black Bow | 26 | 1704187 | Header Stop |
| 5 | | 1704707 Header Guide | 15 | 1702992 | Spring Plunger, 5/8" x 2.15" | 27 | 1118094 | Side Rail End Plugs w/Seal (Set of Two) |
| 6 | * | * | 16 | 1703260 | Tension Control Bracket | 28 | 1705629 | Square Head Screw (#1 Drive) |
| 7 | * | Retainer Strap | 17 | 1115354 | Header Insert Retainer Clip | 29 | 1117467 | Rear Header 08 End Plugs (Set of Two) |
| 8 | | 1706491 Clamp | 18 | 1115174 | Hook Fastener Strips | 30 | * | Black Rear Header |
| 9 | | 1706371 Screw Button Hd M6 x 30MM | 19 | 1703332 | Hitch Pin, 1/16" x 1 5/16" | | | |
| 10 | | 1117594 Header Guide Retainer Assy. | 20 | 1706590 | Side Rail, Passenger's Side | | | |
| | | | 21 | 1706589 | Side Rail, Driver's Side | | | |

* Please specify length or make and model of vehicle.

