

VOLANT AIR INTAKE SYSTEM
 PART NO.: 158666
 INSTALLATION INSTRUCTIONS
 WWW.VOLANT.COM
 TECH SUPPORT: (909) 476-7225

158666 PARTS LIST					
1	VOLANT FILTER BOX	1	4" X 3" HUMPH HOSE	3	1/4" WASHERS
1	VOLANT FILTER BOX LID	1	3 3/4" X 3" SLEEVE	4	1/4" X 7/8" FENDER WASHERS
1	VOLANT FILTER BOX ADAPTER	4	6 MM-25 BOLTS	1	1" O-RING
1	VOLANT AIR FLOW DUCT	3	1/4"-20 BOLTS	2	4 MM PLASTIC SCREWS
1	POWERCORE FILTER W/CLAMP	7	1/4" LOCK WASHERS	1	15866 MAF GASKET
2	#060 CLAMPS	5	1/4"-20 TRUSS HEAD SCREWS		
2	#072 CLAMPS	5	1/4" RUBBER WASHERS		



NOTE: REMOVE THE ADHESIVE COVER FROM THE FENDER WELL IN ORDER TO INSURE MAXIMUM AIR FLOW.

(5) 1/4"-20 TRUSS HEAD SCREWS
 (5) 1/4" RUBBER WASHERS

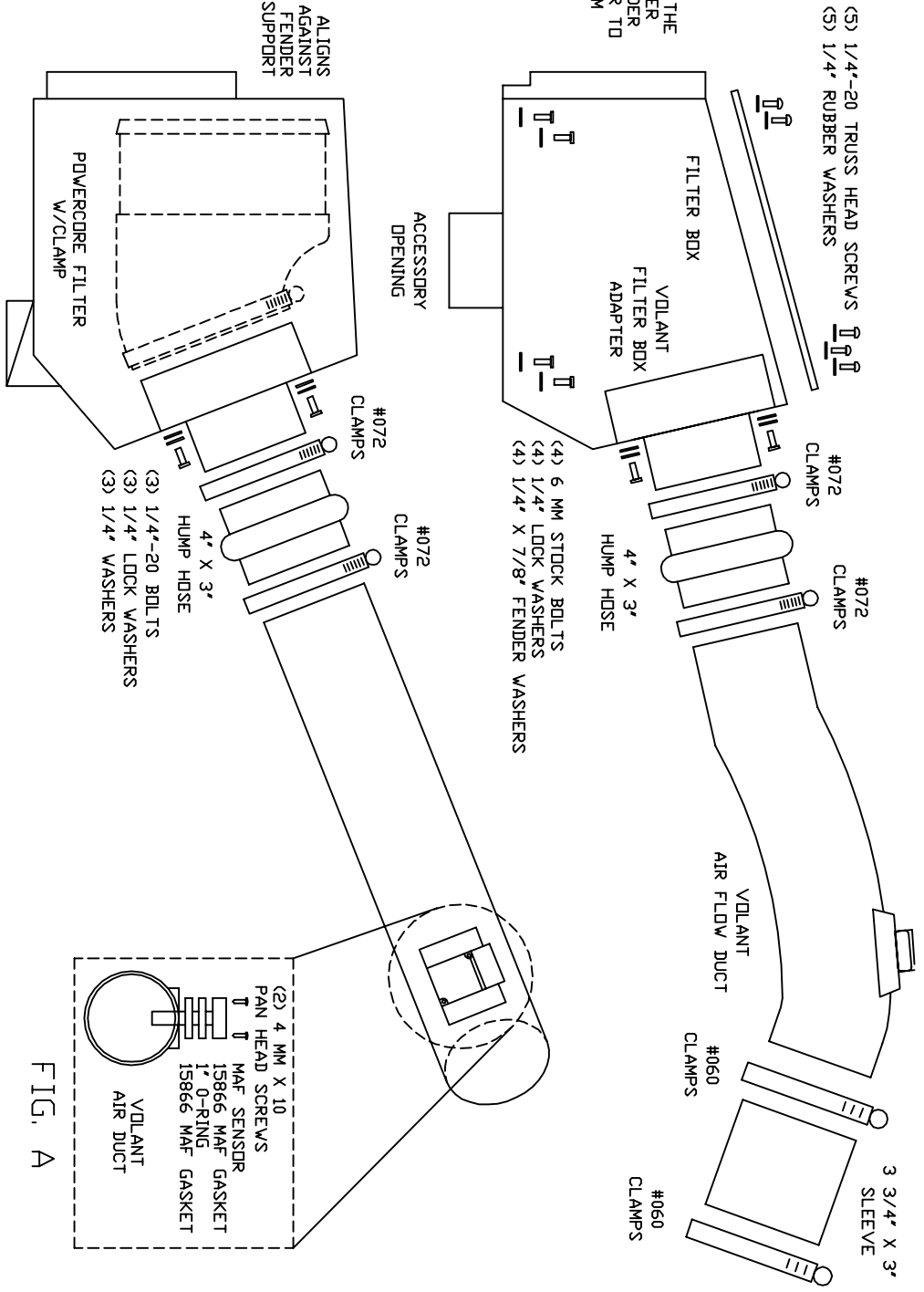
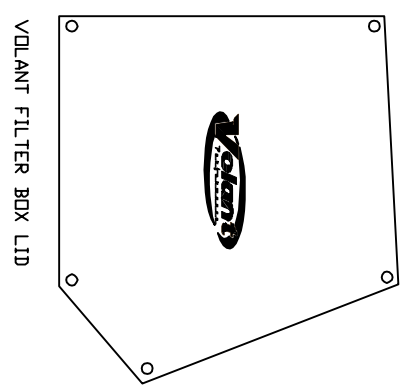

ALIGNS AGAINST FENDER SUPPORT

FIG. A