



Installation Instructions

SPINDLE NUT KIT

P/Ns 27988, 32720, and 32721

As you read these instructions, you will see **NOTES**, **CAUTIONS** and **WARNINGS**. Each message has a specific purpose. **NOTES** are additional information to help you complete a procedure. **CAUTIONS** are safety messages that indicate a potentially hazardous situation which, if not avoided, may result in minor or moderate injury. A **CAUTION** may also be used to alert against unsafe practice. **WARNINGS** are safety messages that indicate a potentially hazardous situation, which, if not avoided could result in serious injury. **CAUTIONS** and **WARNINGS** identify the hazard, indicate how to avoid the hazard, and advise of the probable consequence of not avoiding the hazard. **PLEASE WORK SAFELY!**

WARN INDUSTRIES, INC. □ 12900 SE CAPPS ROAD □ CLACKAMAS, OR 97015-8903
(503) 722-1200 □ CUSTOMER SERVICE LINE 1-800-543-WARN
FAX (503) 722-3000

SAFETY PRECAUTIONS



CAUTION



Read instructions thoroughly before beginning installation.

This sheet provides guidelines to install the WARN Spindle Nut Kit. There are **NOTES**, **CAUTIONS**, and **WARNINGS** which should be followed during installation to avoid possibility of personal injury or damage to the vehicle. During installation, standard safety precautions and equipment should be used where appropriate. Because the skill and experience of the installer and the tools used can vary widely, it is impossible to anticipate all conditions under which this installation is made or to provide cautions for all possible hazards. If your installation varies from the instruction, you must be completely satisfied that your safety or the operation of the vehicle will not be compromised.

APPLICATIONS

WARN Kit P/N 27988 replaces the spindle nuts for these vehicles equipped with automatic locking hubs.
1983 to 1989 Ford Bronco II and Ranger

WARN Kit P/N 32720 replaces the spindle nuts for these vehicles equipped with automatic locking hubs.

- * 1969 to 1991 Chev. / GMC Blazer, Jimmy, Suburban
- * 1969 to 1987 Chev. / GMC ½ Ton Pickup
- * 1977 to 1987 Chev. / GMC ¾ Ton Pickup
- * 1959 to 1996 Ford Pickup
- * 1977 ½ to 1997 Ford Light Duty Pickup
- * 1966 to 1996 Ford Bronco
- * 1990 to 1994 Ford Explorer
- * 1990 to 1997 Ford Ranger
- * 1990 to 1994 Mazda Navajo
- * 1990 to 1997 Mazda Pickup

WARN Kit P/N 32721 replaces the spindle nuts for these vehicles equipped with automatic locking hubs.

- * 1976 to 1987 Chev. / GMC 1 Ton Pickup
- * 1988 to 1990 Chev. / GMC 1 Ton Pickup, V-Series Crew Cab
- * 1978 to 1997 Ford ¾ Ton Heavy Duty Pickup
- * 1978 to 1997 Ford 1 Ton Pickup

* Some of these applications are equipped with Spicer or Borg Warner automatic locking hubs. Only those vehicles equipped with Warn's automatic locking require the spindle nut kit. Warn's hub is identified by three (3) cap screws used to retain the hublock cap assembly. The others use five (5) capscrews.

PARTS LIST

- Inside Bearing Nut with Pin (2)
- Lockwasher (2)
- Outside Bearing Nut (2)

TOOLS NEEDED

- | | | |
|------------------|------------------------------|----------------------------|
| Torx T25 driver | Wheel Bearing Locknut Socket | 20-100 ft-lb torque wrench |
| Snap-ring pliers | Small Pick | 50-250 ft-lb torque wrench |

Figure 1: Dana 30, 44 and 50 Auto Hub Removal

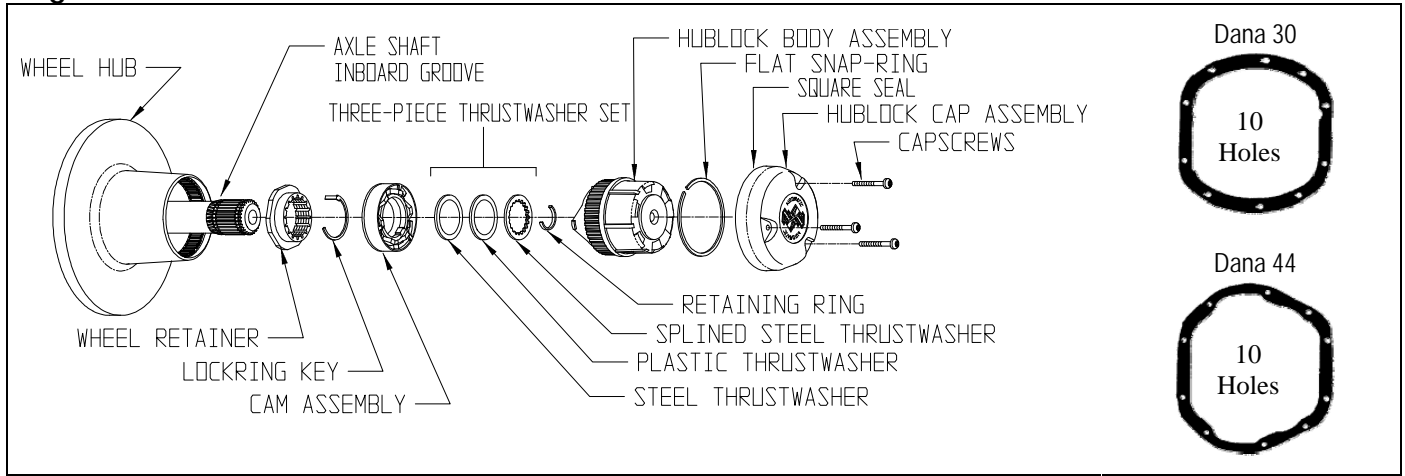

Figure 2: Dana 60 Auto Hub Removal

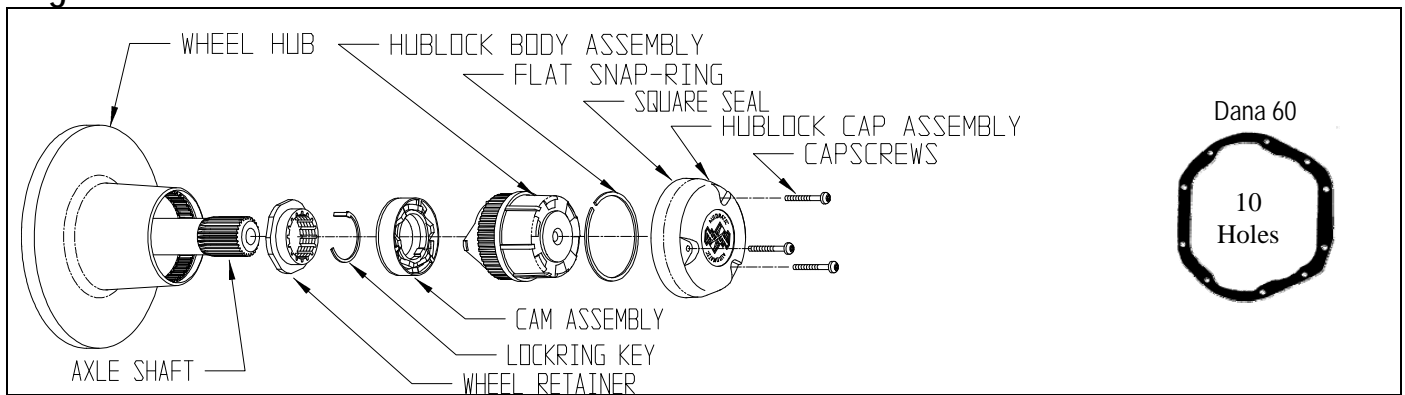

Figure 3: Dana 28 and 35 Auto Hub Removal

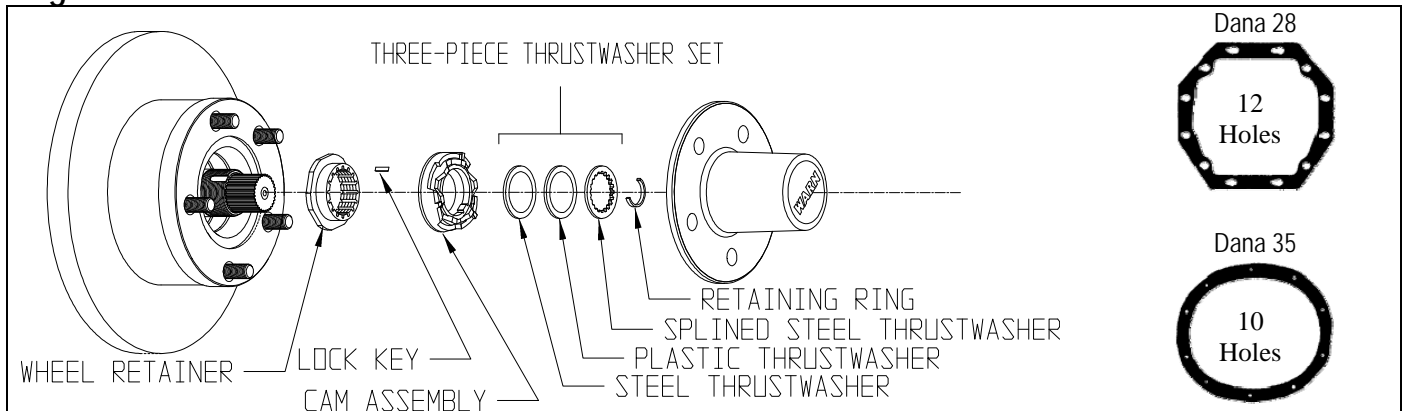
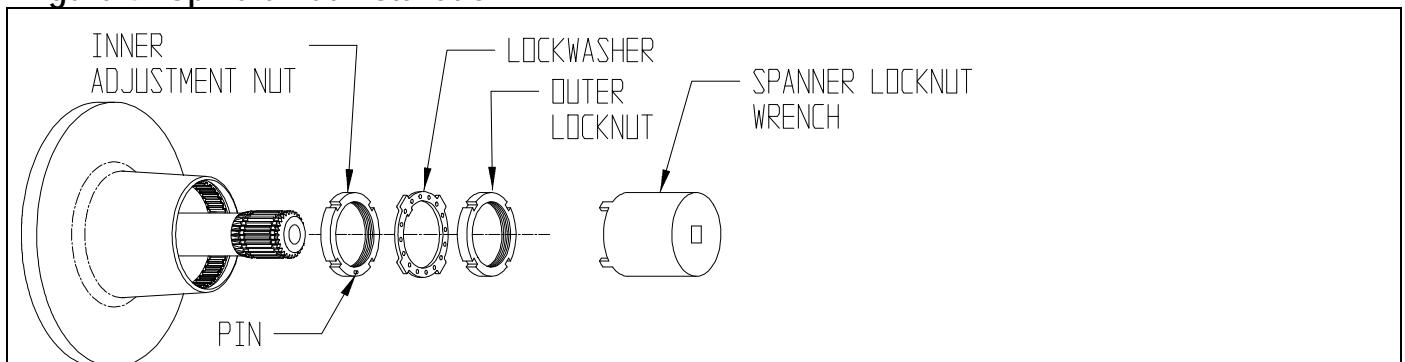

Figure 4: Spindle Nut Installation



Preparation:

1. Turn the ignition key OFF. Put transmission in Park (automatic) or Reverse (manual).
2. Set the parking brake and block the rear wheels. Raise the front end and support it on 2 jack stands.



WARNING



Raised vehicles can cause falling particles. **WEAR SAFETY GOGGLES.** Falling particles can cause eye injury.



Improperly supported vehicles can fall. **DO NOT USE A JACK TO SUPPORT THE VEHICLE. USE JACK STANDS IN PAIRS TO SUPPORT THE VEHICLE. USE JACKS OR JACK STANDS ONLY ON A HARD, STABLE, AND LEVEL SURFACE. DO NOT EXCEED THE RATED CAPACITY OF A JACK OR JACK STANDS.** An unstable vehicle can fall and cause a crushing injury.

A rolling vehicle can cause jackstands to tip. Before working under vehicle, **VERIFY THAT THE PARKING BRAKE IS SET, THE TRANSMISSION IS IN PARK (AUTOMATIC) OR REVERSE (MANUAL) AND THE REAR WHEELS ARE BLOCKED.** A tipping jackstand or vehicle can cause injury.

Remove Automatic Hubs:

Dana 30, 44, and 50 Axle (figure 1)

Remove ALL automatic hub components starting with the Torx head capscrews. Remove the flat snap-ring, hublock body assembly, axle retaining ring, three-piece thrust washer set, cam assembly, lockring key (use a small pick to find and remove), and wheel retainer.

Dana 60 Axle (figure 2)

Remove ALL automatic hub components starting with the Torx head capscrews. Remove the flat snap-ring, hublock body assembly, cam assembly, lockring key (use a small pick to find and remove), and wheel retainer. Some Dana 60 axle configurations are similar to Dana 50 axles.

Dana 28 and 35 (figure 3)

1. Remove the tire and wheel.
2. Remove ALL automatic hub components starting with the hublock body assembly, retaining ring, three-piece thrust washer set, cam assembly, lock key (use a small pick to find and remove), and wheel retainer. Note: Some thrust washer sets include a needle thrust bearing.

Install Manual Hub Spindle Nut Conversion Kit: (figure 4)

1. Install the inner bearing nut and torque the nut to 35 ft-lb (Dana 28 and 35) or 50 ft-lb (all others) while rotating the front disc brake hub back and forth to seat the bearing. NOTE: The inner nut has a pin or post protruding on one side. The pin is used to index into the lockwasher.
2. Back the inner bearing nut off 90 degrees.
3. Install the lockwasher so the key is positioned in the groove of the front spindle. Tighten the inner bearing nut, aligning the pin into the nearest lockwasher hole. Note: The lockwasher hole pattern is offset with the keyway to provide half-position setting by flipping the washer over to obtain closest hole.
4. Install the outer bearing nut and tighten to 85 to 135 ft-lb (Dana 28 and 35) or 160 to 205 ft-lb (all others) using the spanner locknut wrench.

MANUAL HUB OPERATING INSTRUCTIONS:

2WD Operation:

Set both control dials at "FREE" and the transfer case selector at 2WD for free wheeling two wheel drive. Use the "FREE" position for all driving that does not require four wheel traction.

4WD Operation:

To engage four wheel drive, set both hub control dials at "LOCK" move the transfer case selector to 4WD. Do not drive on hard surface roads in this mode. It can result in severe torque wind-up in the gear-train. Return the transfer case to 2WD before unlocking the hubs.

SAFETY PRECAUTIONS



CAUTION



Do not move the vehicle if the control dials are anywhere between "FREE" and "LOCK". To do so may cause hub damage.

Do not move the vehicle with only one hub engaged. To do so can cause damage to the front differential.

Do not move the vehicle with the hubs in the "FREE" position and the transfer case in low range. To do so may damage the rear drive train.

Engage both hub locks and drive for a minimum of one mile each month to insure lubrication of the front axle.



GO PREPARED.

WARN® LOCKING HUBS

LIMITED LIFETIME WARRANTY FOR MECHANICAL COMPONENTS

Warn Industries, Inc. (WARN) warrants to the original purchaser that the mechanical components of the "WARN" Locking Hub will be free of defects in material and workmanship for the lifetime of the hub. This Warranty applies only to the original purchaser of the hub. To obtain any warranty service, you must provide WARN with proof of purchase and date of purchase acceptable to WARN, such as a copy of your purchase receipt. This warranty does not cover the removal or reinstallation of the hub. WARN will, at its option, repair, replace or refund the purchase price of a defective hub or component, provided you return the defective hub or component during the warranty period, transportation charges prepaid, to Warn Industries' Service Department or a Factory Authorized Service Center. Attach your name, address, telephone number, a description of the problem, and a copy of your receipt and original bill of sale of the defective hub and date of purchase.

This warranty does not apply (i) to finish, or (ii) if the hub has been damaged by accident, abuse, misuse, collision, overloading, modification, misapplication, improper installation, or improper service. Commercial or industrial use or application voids the warranty.

THE WARRANTY SET FORTH ABOVE IS THE ONLY WARRANTY. THERE ARE NO OTHER WARRANTIES, EXPRESS OR IMPLIED, INCLUDING BUT NOT LIMITED TO IMPLIED WARRANTIES OF MERCHANTABILITY OR FITNESS FOR A PARTICULAR PURPOSE.

ANY IMPLIED WARRANTY WHICH BY LAW MAY NOT BE EXCLUDED IS LIMITED IN DURATION TO ONE (1) YEAR FROM THE DATE OF ORIGINAL RETAIL PURCHASE OF THE PRODUCT.

WARN SHALL NOT BE LIABLE FOR SPECIAL, INDIRECT, INCIDENTAL OR CONSEQUENTIAL DAMAGES (INCLUDING, BUT NOT LIMITED TO, LOST PROFITS, DOWN TIME OR LOSS OF USE) UNDER ANY LEGAL THEORY, EVEN IF WARN WAS ADVISED OF THE POSSIBILITY OF SUCH DAMAGES.

Some states do not allow the exclusion of implied warranties or the exclusion or limitation of liability for incidental or consequential damages, or limitations on how long an implied warranty lasts, so the above limitation or exclusion may not apply to you. This warranty gives you specific legal rights. You may also have other rights that vary from state to state.

WARN reserves the right to change Product design without notice. In situations in which WARN has changed a Product design, WARN shall have no obligation to upgrade or otherwise modify previously manufactured Products.

No WARN dealer, agent or employee is authorized to make any modification, extension or addition to this warranty.

Warranty inquiries and Products returned for warranty service should be sent to:

WARN INDUSTRIES, INC

Customer Service Department
12900 SE Capps Road

Clackamas, OR 97015
1-800-543-WARN (1-800-543-9276)
1-503-722-3005 International Fax

Products Covered By this Warranty
Locking Hubs

Products Not Covered by this Warranty
Finish to Locking Hubs