



INSTALLATION INSTRUCTIONS

PLOW MOUNTING KIT

PART NUMBER: 84354
APPLICATION: 2002 + ARCTIC CAT 400-1000cc

Your safety, and the safety of others, is very important. To help you make informed decisions about safety, we have provided installation and operating instructions and other information on labels and in this guide. This information alerts you to potential hazards that could hurt you or others. It is not possible to warn you about all potential hazards associated with this product, you must use your own good judgment.

CARELESS INSTALLATION AND OPERATION CAN RESULT IN SERIOUS INJURY OR EQUIPMENT DAMAGE. READ AND UNDERSTAND ALL SAFETY PRECAUTIONS AND OPERATING INSTRUCTIONS BEFORE INSTALLING AND OPERATING THIS PRODUCT.

This guide identifies potential hazards and has important safety messages that help you and others avoid personal injury or death. **WARNING** and **CAUTION** are signal words that identify the level of hazard. These signal words mean:

▲ WARNING signals a hazard that *could* cause serious injury or death, if you do not follow recommendations. **▲ CAUTION** signals a hazard that *may* cause minor to moderate injury, if you do not follow recommendations.

This guide uses **NOTICE** to call attention to important mechanical information, and **Note**: to emphasize general information worthy of special attention.

▲ WARNING

INJURY HAZARD

Failure to observe these instructions could lead to severe injury or death.

- Always Read the Plow Operator's Manual, the Winch Operator's Manual and all warning labels before operating.
- Always use extreme caution when drilling on any vehicle. Make sure that all fuel lines, brake lines, electrical wires, and other objects are not punctured or damaged when/if drilling on the vehicle. Thoroughly inspect the area to be drilled (on both sides of material) prior to drilling, and relocate any objects that may be damaged. Failure to inspect the area to be drilled may result in vehicle damage, electrical shock, fire or personal injury.
- Always wear safety glasses when installing this kit. A drilling operation will cause flying metal chips. Flying chips can cause eye injury.
- Always use extreme caution when cutting and trimming during fitting.
- Always remove jewelry and wear eye protection.
- Never lean over battery while making connections.
- Never route electrical cables:
 - Across any sharp edges.
 - Through or near moving parts.
 - Near parts that become hot.
- Always insulate and protect all exposed wiring and electrical terminals.
- Always install terminal boots as directed in installation instructions.
- Always use appropriate and adequate care in lifting components into place.
- Always insure components will remain secure during installation and operation.
- Always tighten all nuts and bolts securely, per the installation instructions.
- Always operate the vehicle at a walking speed with the blade installed. Never exceed 5 mph (8 km/h), even with blade up.
- Always plow cautiously, impact with hidden or stationary object may cause the vehicle to stop suddenly or go out of control.
- Never operate the vehicle on slopes greater than 10 degrees with the plow installed.
- Never stand or ride on the plow.
- Always stay clear of moving parts and joints. Always keep others away when operating or adjusting plow.
- Always perform regular inspections and maintenance on the plow mechanism, fasteners, cable and related hardware.
- Always replace all worn or damaged parts before operating.
- Never operate this WARN product with damaged or missing parts.
- Always drive slowly over bumpy and rough terrain. Driving at speeds that cause the plow to bounce while in the up position can cause the winch to back-drive, causing the plow to work its way down. This may result in the plow impacting a stationary object and cause damage to the vehicle and operator injury or death.
- Always drive at speeds such that the plow does not bounce and be aware of the plow position while driving at all times.
- Always be aware that the purpose of the j-bolt is to break the connection between the plow and the winch, to prevent serious damage to the ATV if the plow is raised too high. The plow blade will drop suddenly if the j-bolt breaks, so always be sure there are no bystanders when you raise and lower the plow.
- Never raise the top of the plow above the headlights of the ATV, as it may damage the vehicle and plow.
- Always replace a deformed or broken j-bolt with the spare j-bolt included in the kit.

⚠ CAUTION
Moving Parts Entanglement Hazard
Failure to observe these instructions could lead to minor or moderate injury.
<input type="checkbox"/> Always take time to fully read and understand the installation and Operations Guide included with this product. <input type="checkbox"/> Never operate this product if you are under 16 years of age. <input type="checkbox"/> Never operate this product when under the influence of drugs, alcohol or medications.
Read installation and operating instructions thoroughly.

Notice
Equipment Damage
<input type="checkbox"/> ALWAYS REFER TO THE INSTALLATION AND SPECIFICATION GUIDE, SUPPLIED IN THE WINCH KIT, FOR ALL WIRING SCHEMATICS AND SPECIFIC DETAILS ON HOW TO WIRE THIS WARN PRODUCT TO YOUR VEHICLE. <input type="checkbox"/> Never overtighten the j-bolt to the bracket. Doing so will pinch the winch cable against the bracket, damaging the cable. <input type="checkbox"/> Always put the end of the actuator cable through the slot in the Termination Bracket. Terminating the cable through any other hole in the bracket will cause the bracket to not function properly and will drastically reduce the life of the actuator cable.
Read installation and operating instructions thoroughly.

II. TABLE OF CONTENTS

Tools Requiredpage 2
Torque Specificationspage 2
Parts Listpage 3
Installationpage 4-6
Maintenance/Care page 7

III. TOOLS REQUIRED

- 3/8" Ratchet, 3 1/2" Extension
- Sockets: 10mm, 13mm, 17mm, Deep 1/2"
- T30 Torx Head
- Drill and 3/8" Drill Bit

IV. TORQUE SPECIFICATIONS

1/4	8 lb. ft. (10.8 N-m)
5/16	17 lb. ft. (12.5 N-m)
3/8/ 10mm	30 lb. ft. (40.7 N-m)
7/16	50 lb. ft. (67.8 N-m)
1/2	75 lb. ft. (101.7 N-m)

V. PARTS LIST

<u>Ref</u>	<u>Description</u>	<u>Qty</u>
A1	Plow Mount	1
A2	RH Locate Bracket	1
A3	LH Locate Bracket	1
A4	Plow Jogged RH	1
A5	Plow Jogged LH	1
B1	Plow Retaining Pin	2
B2	5/16 x 1 3/8 U-Bolt	2
B3	5/16 x 1 1/2 U-Bolt	2
B4	5/16 Flat Washers	8
B5	5/16 Lock Nut	8
B6	3/8 Flat Washer	2
B7	M10-1.25 x 30 mm Hex Bolt	2
B8	1/4-20 Hex Head Bolt	4
B9	1/4-20 Flat Washer	8
B10	1/4-20 Lock Nut	4
B11	Nut Clip	2

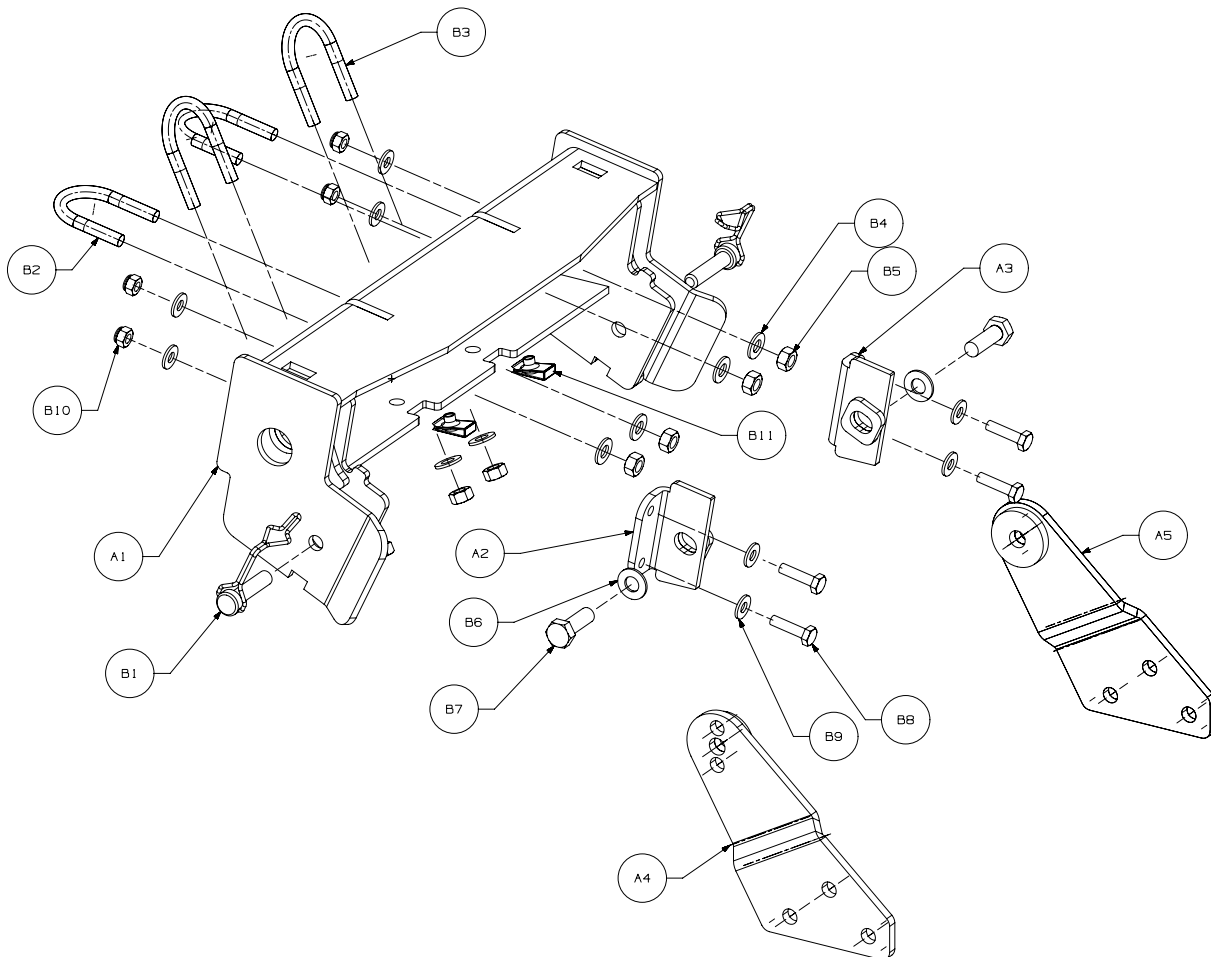

VI. INSTALLATION

1. Remove the plastic front skid plate (Figure 1). Use a T30 Torx head to remove the four bolts securing the front skid plate to the front bumper.

Note: Removing the bottom two T30 bolts will cause the plastic belly skid plate to hang freely from the front. Leave hanging until instructed to drill holes in the end of this document.

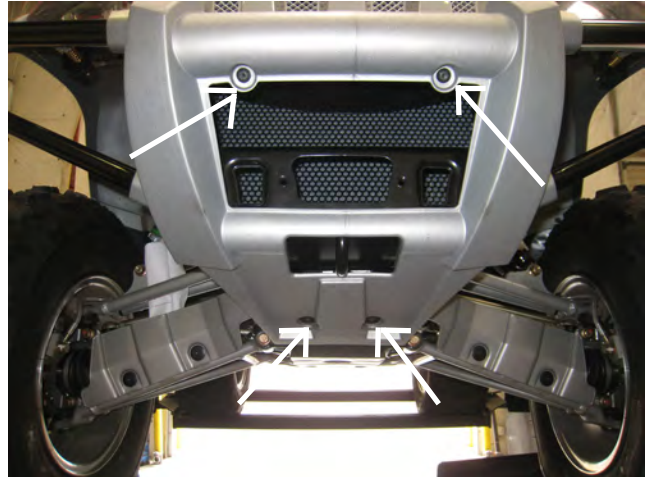

Figure 1

2. Remove the front bumper. Use a 10mm socket to remove the upper two bolts securing the front bumper to the frame, and a 13mm socket to remove the two bolts securing the bumper to the lower frame tube. (Figure 2)

⚠ CAUTION	
Moving Parts Entanglement Hazard	
Failure to observe these instructions could lead to minor or moderate injury.	
<input type="checkbox"/>	Once the bumper is freed from the mount it can fall from the vehicle. To prevent personal injury and damage to the bumper/vehicle, remove the top two bolts but only remove one of the bottom bolts. Hold the bumper with one hand then remove the last bottom bolt.
Read installation and operating instructions thoroughly.	



Figure 2

3. Attach the LH and RH locating bracket to the plow mount. Use the supplied 1/4-20 hex head bolts, washers and lock nuts as shown in Figure 3. Tighten the nuts just enough to take the slack out of the bolts but allowing the brackets to slide. See Figure 3.

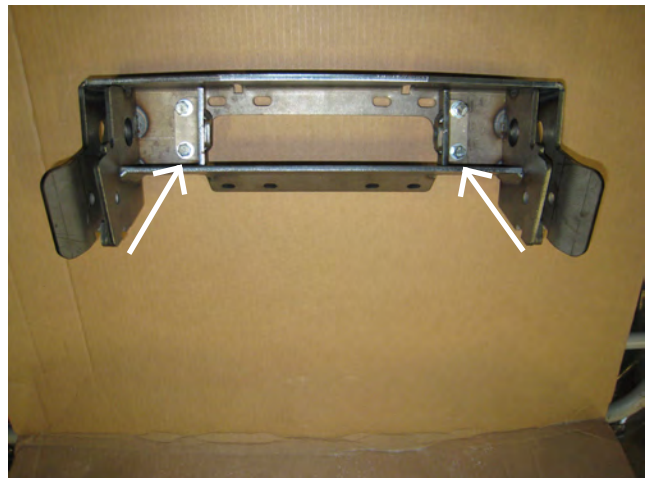

Figure 3

INSTALLATION CONT.

4. Place the plow mount over the bottom frame tube. Ensure the plastic belly skid plate is between the mount and the frame.

Install the two M10x 1.25 bolts through the central holes and into the bottom frame tube. **Do not tighten, this is for positioning only.** See Figure 4.

5. Place two 5/16" x 1 3/8" U-bolts around the two upright tubes and through the slotted holes in the back of the face of the plow mount. Secure with (4) 5/16" Flat washers and (4) 5/16" Nylock Nuts.

Tighten the U-Bolt nuts just enough to take the slack out of the bolts but do not tighten. As you will need to slide the mount upward into position for the next step. See Figure 5.

6. Drill two holes into the plastic belly skid plate where the inner/lower slotted holes are located on the bottom tab of the plow mount. Place two 5/16" x 1 1/2" U-bolts around the two bottom frame tubes and through the slotted holes on the bottom tab of the plow mount. Secure with (4) 5/16" Flat Washers and (4) 5/16" Nylock Nuts. Do not tighten. (Figure 5)

7. Making sure the mount is centered on the vehicle, tighten the two upper U-Bolts. Tighten each nut to the torque specified in the Table at the beginning of this document. Back the previously installed M10 bolts out about half way. Make sure that the LH and RH locating brackets still slide after you tightened the upper u-bolts in the previous step.

8. Tighten the two lower U-Bolts. Tighten each nut to the torque specified in the table at the beginning of this document.

9. Remove the two M10 X 1.25 bolts from the central holes.

10. Install the front bumper. First, install the top two bolts and loosely secure. Then bring the smashed bottom ends in between the inner locating tabs of the plow mount. Thread the (2) M10 X 1.25 bolts through the tab, spacers, flattened bumper tube end, and into the bottom frame tube. Tighten to the torque specified in the table at the beginning of this document. Tighten the 1/4-2 hex head bolt that attach the inner locating tabs at this time. See Figure 6.

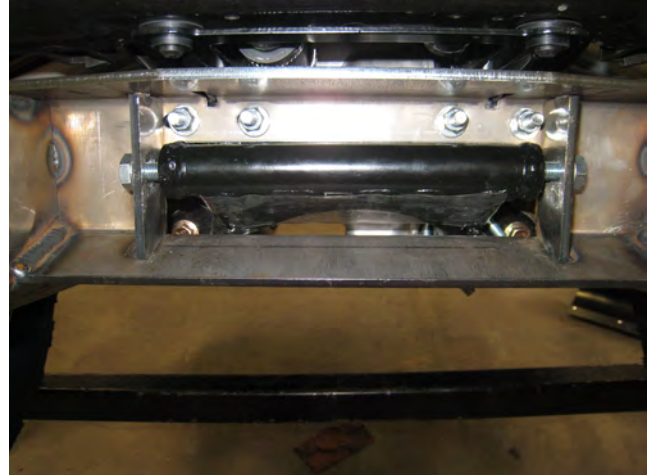

Figure 4

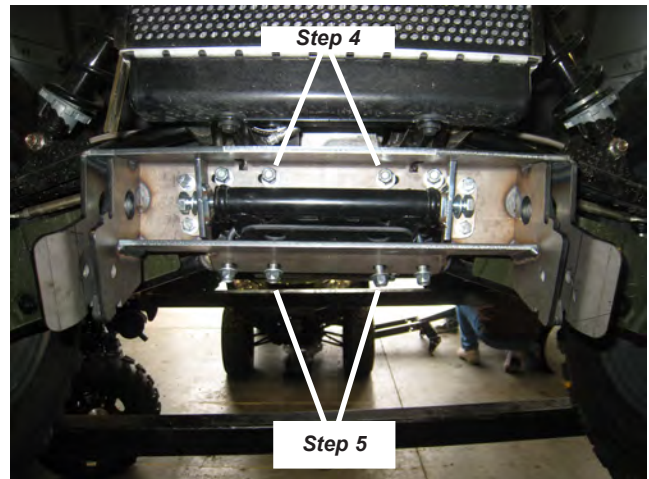

Figure 5



Figure 6

11. There is some pre-trimming to your front skid plate required before installation. See Figure 7. This can be achieved with a utility knife or a heavy pair of scissors. Mark 3 1/2 inches up from the bottom end of the skid plate and 1 1/2 inches down on the side and cut that material away.



Figure 7

12. Reinstall your plastic using the factory fasteners. Make sure that the threaded u-clips have been installed lower part of the plow mount over the mounting holes. See instruction exploded view for location on page 3. Figure 8 shows plastic reinstalled.



Figure 8

13. Finally install the plow mounting tabs to your Plow Tube Assembly with the jogged ends toward the center (narrowest configuration possible) shown in Figure 9. Install these loosely on the plow with the fasteners provided with the plow. Tighten the fasteners after the plow is assembled and installed in the mount according to the plow assembly instructions.

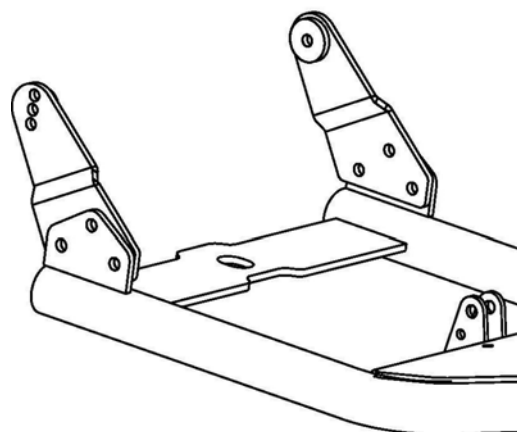

Figure 9

VII. MAINTENANCE/CARE

- Inspect all metal parts on the plow, plow mount, and related hardware. Replace all parts that appears rusted or deformed prior to use.
- Inspect all nuts and bolts on the plow, plow mount, and related hardware prior to each use. Tighten all nuts and bolts that appear to be loose. Stripped, fractured, or bent bolts or nuts need to be replaced immediately.
- Check all cables prior to use. Replace cables that are worn or frayed.
- Check all moving and rotating parts. Remove debris that may inhibit the part from moving freely.