



INSTALLATION INSTRUCTIONS

Winch Mounting Kit

Winch Mount Kit: 83408

Application: Polaris Sportsman XP 2009+

Your safety, and the safety of others, is very important. To help you make informed decisions about safety, we have provided installation and operating instructions and other information on labels and in this guide. This information alerts you to potential hazards that could hurt you or others. It is not possible to warn you about all potential hazards associated with this product, you must use your own good judgment.

CARELESS INSTALLATION AND OPERATION CAN RESULT IN SERIOUS INJURY OR EQUIPMENT DAMAGE. READ AND UNDERSTAND ALL SAFETY PRECAUTIONS AND OPERATING INSTRUCTIONS BEFORE INSTALLING AND OPERATING THIS PRODUCT.

This guide identifies potential hazards and has important safety messages that help you and others avoid personal injury or death. **WARNING** and **CAUTION** are signal words that identify the level of hazard. These signal words mean:

▲ WARNING signals a hazard that *could* cause serious injury or death, if you do not follow recommendations. **▲ CAUTION** signals a hazard that *may* cause minor to moderate injury, if you do not follow recommendations.

This guide uses **NOTICE** to call attention to important mechanical information, and **Note**: to emphasize general information worthy of special attention.

▲ WARNING

INJURY HAZARD

Failure to observe these instructions could lead to severe injury or death.

- ❑ **Always** use extreme caution when drilling on any vehicle. Make sure that all fuel lines, brake lines, electrical wires, and other objects are not punctured or damaged when / if drilling on the vehicle. Thoroughly inspect the area to be drilled (on both sides of material) prior to drilling, and relocate any objects that may be damaged. Failure to inspect the area to be drilled may result in vehicle damage, electrical shock, fire or personal injury.
- ❑ **Always** wear safety glasses when installing this kit. A drilling operation will cause flying metal chips. Flying chips can cause eye injury.
- ❑ **Always** use extreme caution when cutting and trimming during fitting.
- ❑ **Always** remove jewelry and wear eye protection.
- ❑ **Never** lean over battery while making connections.
- ❑ **Never route electrical cables:**
 - Across any sharp edges.
 - Through or near moving parts.
 - Near parts that become hot.
- ❑ **Always** insulate and protect all exposed wiring and electrical terminals.
- ❑ **Always** install terminal boots as directed in installation instructions.
- ❑ **Always** use appropriate and adequate care in lifting components into place.
- ❑ **Always** insure components will remain secure during installation and operation.
- ❑ **Always** tighten all nuts and bolts securely, per the installation and operation.
- ❑ **Always** perform regular inspections and maintenance on the winch, winch mount and related hardware.
- ❑ **Never** operate this **WARN** product with damaged or missing parts.

CAUTION

Moving Parts Entanglement Hazard

Failure to observe these instructions could lead to minor or moderate injury.

- Always** take time to fully read and understand the installation and Operations Guide included with this product.
- Never** operate this product if you are under 16 years of age.
- Never** operate this product when under the influence of drugs, alcohol or medications.

Read installation and operating instructions thoroughly.

Notice

Equipment Damage

- Always** refer to the Installation and Specification Guide, supplied in the winch kit, for all wiring schematics and specific details on how to wire this WARN product to your vehicle.

Read installation and operating instructions thoroughly.

Table of Contents

I.	Parts List.....	2
II.	Tools Required.....	2
III.	Installation.....	3-6
V.	Maintenance/Care	7

I. Parts List

<i>Ref</i>	<i>Description</i>	<i>Qty</i>
A1	Winch Mounting Plate Sportsman XP	1
A2	Spacer Winch Sportsman	2
B1	Flat Washer	4
B2	M8 x 25mm Bolt	4
B3	M8 Lock Nut	4

II. Tools Required

- Ratchet
- Sockets: 10mm, 1/2"
- Wrenches: 1/2"

III. INSTALLATION

1. Remove winch Tie Bolt

The Tie Bolt at the bottom of the winch must be removed before installation on winch mounting plate. (Figure 1)

Use a Phillips head screwdriver to remove this screw.

Never operate the winch without the bottom tie bolt or a winch mounting plate installed. These parts insure that the drum supports are evenly spaced at the top and bottom.

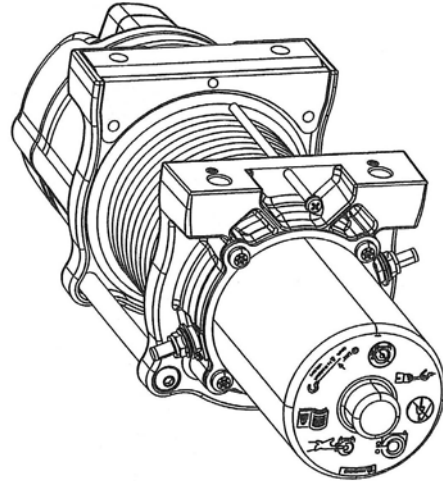

Figure 1

2. Install winch in Mount

Fairlead mounting bolts must be placed in mounting plate before installing winch.

Secure the winch to the mounting plate with the M8 bolts supplied with your winch. The shim plates shown in Figure 2 must be installed as shown.

The longer M8 mounting bolts must be installed in the drum support attached to the motor.

See your winch installation instructions for complete instructions. Be sure to torque the M8 mounting bolts to the specification in winch installation instruction.

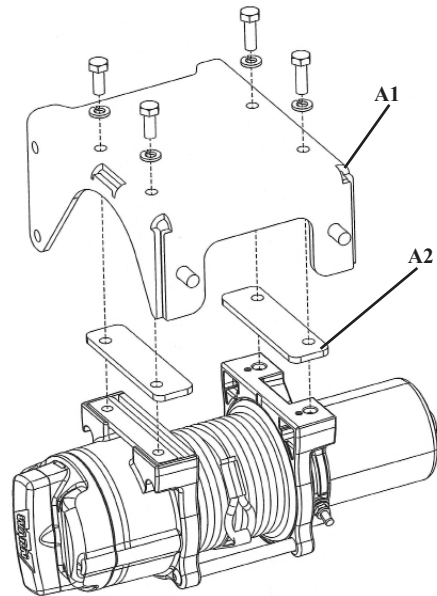

Figure 2

3. Install Fairlead on Mount

The fairlead mounting bolts must be installed from the inside of the mounting plate as shown in Figure 3.

NOTE: The plow mounting bracket will be fastened to the front of the winch mount bracket. See your plow installation instruction at this time if installing a plow.

Use the roller fairlead hardware supplied with the winch to secure the roller fairlead.

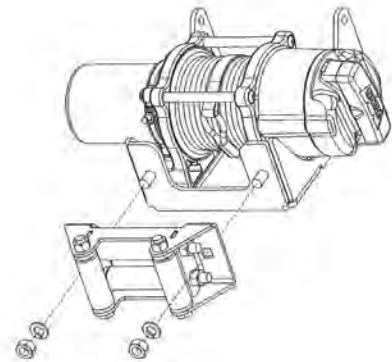

Figure 3

4. Install wires on Winch

The Yellow and Blue winch wires must be installed on Winch before mounting to vehicle.

The motor terminals are color coded. Install both wires with a boot as shown in Figure 4.

See winch installation instruction for terminal nut torque specification.



Figure 4

5. Remove Front Lower Bumper

Remove the four bolts securing the lower bumper section to the frame.

Figure 5 shows frame with lower bumper removed.



Figure 5

6. Install Winch and Mount on Frame

Pull the winch wires up into the frame so that the winch and mount can be secured to the frame as shown in Figure 6.

Secure the winch and mount to the frame with the M8 x 25mm bolts, washers, and M8 lock nuts as shown in Figure 7.

Install the rope hook and strap that were supplied with the winch kit.



Figure 6

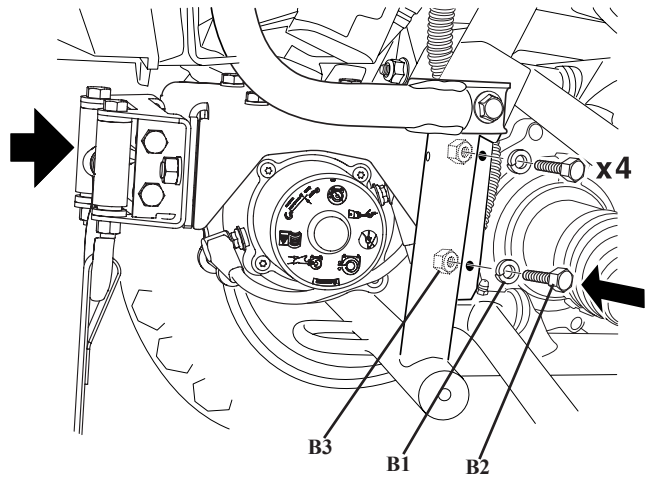

Figure 7

7. Route Winch Wires to Contactor

See your winch installation instructions for details on routing the electrical wires to the contactor.

Be sure to secure the wires with electrical ties to the frame.

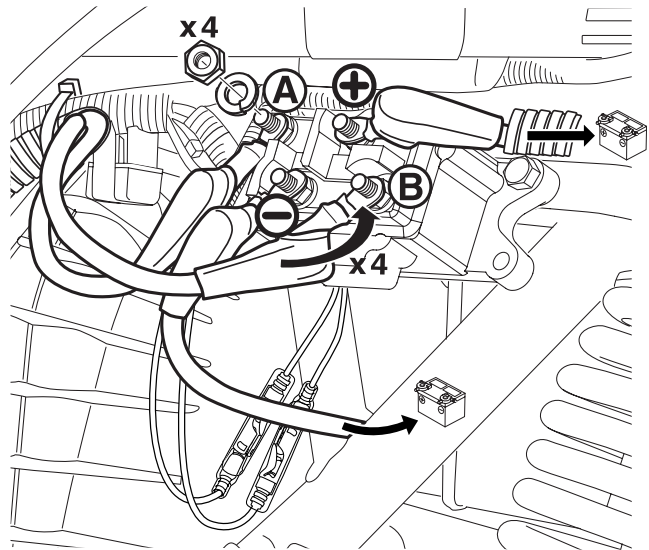

Figure 8

8. Install Contactor in Left Rear Wheelwell

Install the contactor in the left rear wheelwell as shown in Figure 8 and 9. Secure the contactor to the frame with the hardware supplied with the winch.

Secure the winch wires to the contactor with electrical boots installed to protect terminals.

Secure the battery wires to the contactor with electrical boots to protect the terminals.



Figure 9

9. Route Battery Wires to Battery

Route the battery wires from the contactor to the battery.

Install the winch control switch per the winch installation instructions.

10. Connect the battery wires to the battery.

Secure all wires making sure that they do not come in contact with any sharp edges or surfaces that will become hot.

11. Reinstall front lower bumper.

Finally, reinstall the lower section of the front bumper.

Review the winch installation instructions to complete the installation of the winch.



Figure 10



Figure 11

⚠ WARNING

FAILURE TO SECURELY TIGHTEN ALL BOLTS ON THE WINCH PLATE, WINCH, AND FAIRLEAD CAN RESULT IN PRODUCT FAILURE WHICH MAY RESULT IN VEHICLE DAMAGE AND OPERATOR INJURY OR DEATH. DOUBLE CHECK THAT ALL BOLTS ARE SECURELY TIGHTENED PRIOR TO USE.

Notice

IT SHOULD BE NOTED THAT THE FOLLOWING INSTRUCTIONS ARE UNIT SPECIFIC. THE FOLLOWING INSTRUCTIONS SHOULD BE REFERRED TO AS REFERENCE INSTRUCTIONS TO ASSIST WIRING THE WINCH FROM THE INSTALLATION AND SPECIFICATION GUIDE SUPPLIED IN THE WINCH KIT.

⚠ WARNING

READ THE VEHICLE'S OPERATOR MANUAL, WINCH OPERATOR MANUAL, AND ALL WARNING LABELS PRIOR TO OPERATION OF ATV AND WINCH.

WARNING

AVOID ALL MOVING AND POTENTIALLY HOT COMPONENTS OF ATV WHEN ROUTING ELECTRICAL CABLES. AVOID AREAS WHERE THE WIRING COULD BE PINCHED WHEN COMPONENTS ARE REINSTALLED. FAILURE TO DO SO CAN RESULT IN PRODUCT FAILURE WHICH CAN LEAD TO VEHICLE DAMAGE AND OPERATOR INJURY OR DEATH.

⚠ WARNING

AVOID ALL MOVING AND POTENTIALLY HOT COMPONENTS OF ATV WHEN ROUTING ELECTRICAL CABLES. AVOID AREAS WHERE THE WIRING COULD BE PINCHED WHEN COMPONENTS ARE REINSTALLED. FAILURE TO DO SO CAN RESULT IN PRODUCT FAILURE WHICH CAN LEAD TO VEHICLE DAMAGE AND OPERATOR INJURY OR DEATH.

V. MAINTENANCE/CARE

1. Inspect all parts on the winch, winch mount, and related hardware prior to each use. Replace all hardware that appears rusted or deformed.
2. Inspect all nuts and bolts on the winch, winch mount, and related hardware prior to each use. Tighten all nuts that appear to be loose. Stripped, fractured, or bent bolts or nuts need to be replaced.
3. Check all cables prior to use. Replace cables that look worn or frayed.
4. Check all moving or rotating parts. Remove debris that may inhibit the part from moving freely.

⚠ WARNING

PERFORM REGULAR INSPECTIONS ON THE WINCH, WINCH MOUNT, AND RELATED HARDWARE. NEVER OPERATE THE WINCH WITH DAMAGED OR MISSING PARTS. FAILURE TO FOLLOW THIS WARNING MAY CAUSE VEHICLE DAMAGE AND OPERATOR INJURY OR DEATH.