

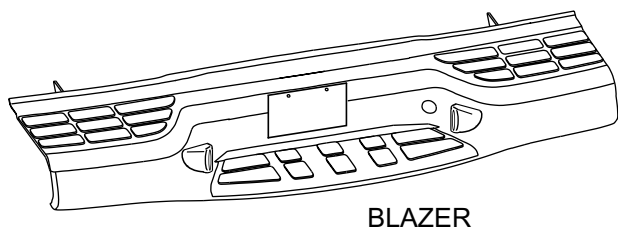

INSTALLATION INSTRUCTIONS

APPLICATION: 1998-02 GMC/CHEVY BLAZER
1998-03 GMC/CHEVY S-10 PICK-UP
BUMPER KIT: 31007, 32007, 35007, 32009, 36009



BLAZER

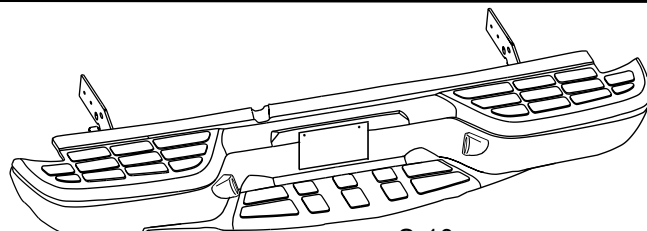

S-10

ITEM NO.	QTY	PART KIT CONTENTS DESCRIPTION	TOOLS REQUIRED
①	4	1/2"-13 X 1.25" HEX HEAD BOLT	3/4" OPEN END WRENCH 3/4" SOCKET RATCHET 6" EXTENSION TORQUE WRENCH WIRE CRIMPING TOOL 5/8" WRENCH 5/8" SOCKET 11/16" SOCKET 11/16" OPEN END WRENCH NYLON STRAPS (OPT. FOR LIGHT KIT)
②	4	1/2" FLAT WASHER	
③	4	1/2"-13 HEX NUT LOCK FLANGED	
④	8	7/16"-14 X 1.25" HEX HEAD BOLT	
⑤	16	7/16" FLAT WASHER	
⑥	8	7/16" HELICAL SPLIT LOCK WASHER	
⑦	8	7/16"-14 HEX NUT	
⑧	4	7/16"-14 HEX NUT LOCK FLANGED	
⑨	2	#14 SELF TAPPING SCREWS	
BUMPER KIT CONTENTS DESCRIPTION			

1	BUMPER
1	LICENSE PLATE LIGHT KIT

STEP 1. Detach the plastic, top step pad from the bumper by pinching the plastic trees together as shown in Figure 1. Be careful not to damage the trees.

STEP 2. Remove the bolt plates. Figure 1.1.

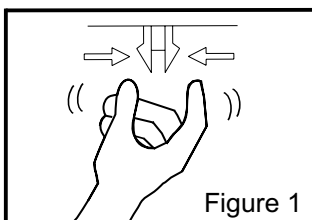

Figure 1

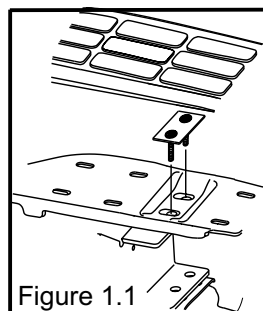
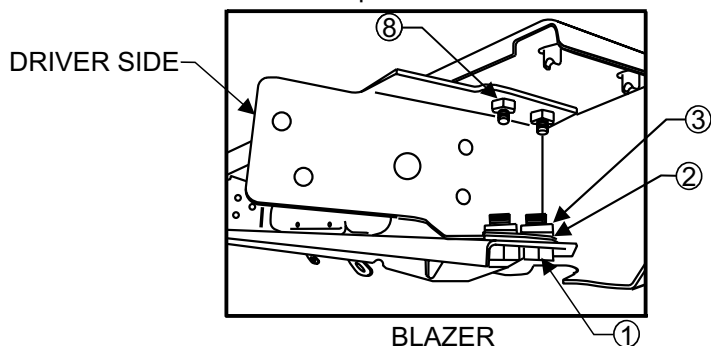
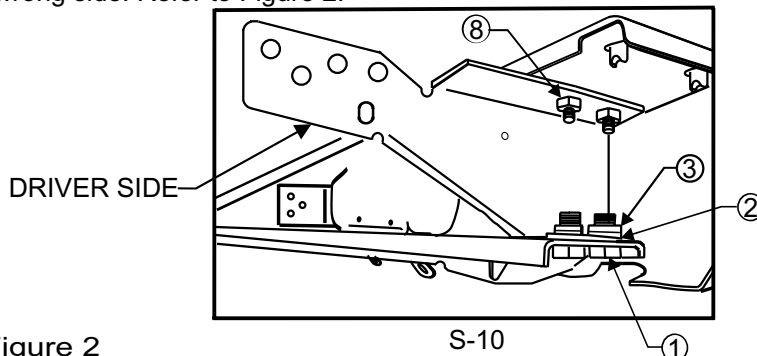

Figure 1.1

STEP 3. Position the mounting brackets as shown, aligning the bracket holes with the bumper holes. Make sure the bracket is not upside down or mounted on the wrong side. Refer to Figure 2.



BLAZER



S-10

Figure 2

- STEP 4. Reinstall the bolt plates.
- STEP 5. Hand tighten (2) 7/16"-14 locking flanged nut onto each bolt plate.
- STEP 6. Reinstall the plastic, top step pad onto the bumper by hand, ensuring that all plastic trees are snapped into place.
- STEP 7. Pass (1) 1/2"-13 X 1.25" bolt along with (2) 1/2" washers through each of the bottom mounting holes.
- STEP 8. Hand tighten (1) 1/2"-13 locking flanged nut onto each bolt. Use a 3/4" open ended wrench to prevent each bolt from rotating while tightening each nut.
- STEP 9. Install license plate lights into bumper. Refer to Figure 3.

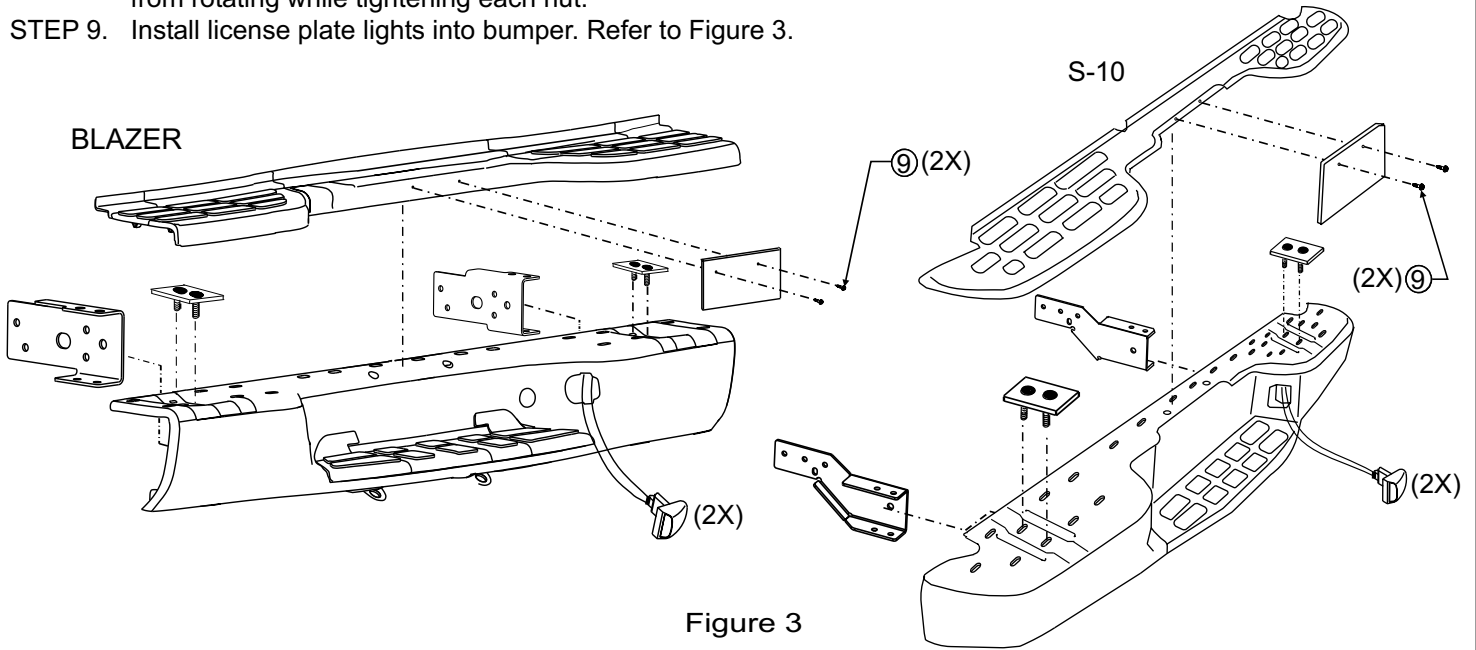

Figure 3

- STEP 10. Position bumper to the frame of the vehicle so that the mounting holes on the bumper's hitch align with the mounting holes on the frame of the vehicle. Refer to Figure 4.
- STEP 11. Pass 7/16"-14 X 1.25" bolt along with (2) 7/16" flat washers and (1) 7/16" split lock washers through each mounting bracket hole and into the vehicle's frame. Refer to Figure 4.
- STEP 12. Hand tighten (1) 7/16"-14 nut onto each bolt. Use a 5/8" open ended wrench to prevent each bolt from rotating while tightening each nut.
- STEP 13. Splice light wires into truck wiring using supplied connectors. Ensure license plate lights are functioning properly. Position the bumper squarely to the rear of the vehicle. Allow enough clearance for the tailgate to open. Once the bumper has been positioned properly, torque each nut to 48-53 ft.-lbs. (65-70 N m).
- STEP 14. Use #14 self-tapping screws to install license plate. Refer to Figure 3.

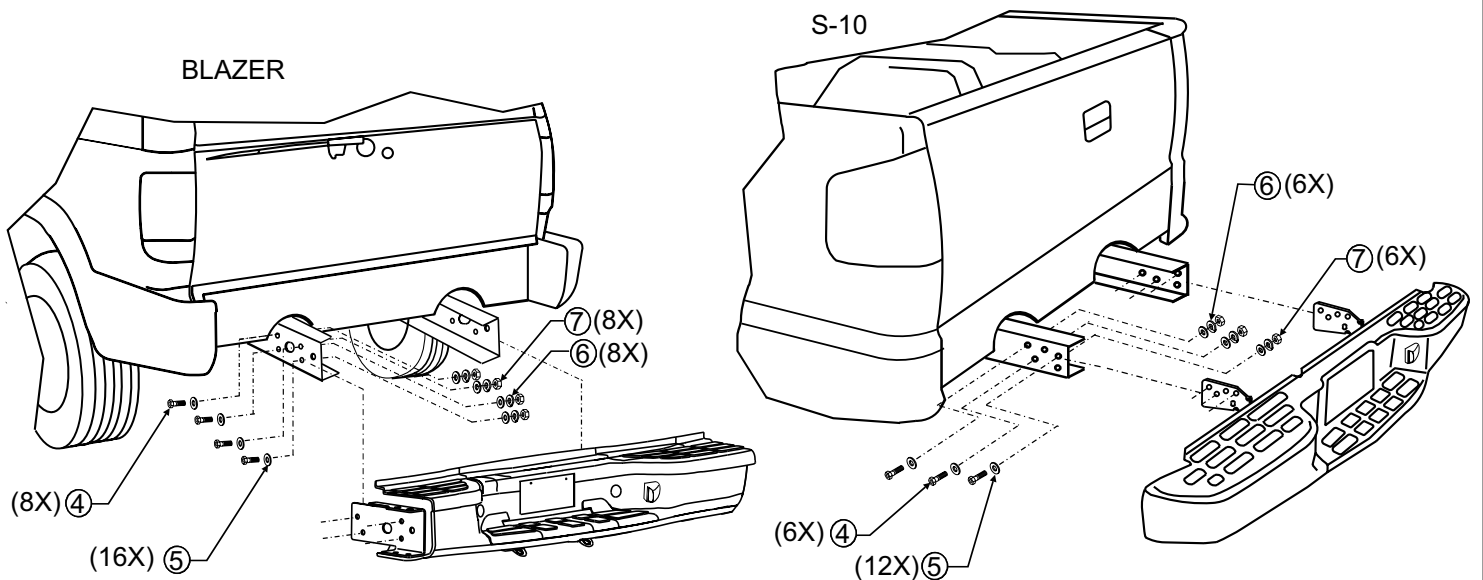

Figure 4