



AUTOMOTIVE PRODUCTS, INC.

INSTRUCTIONS—INSTRUCCIONES—CONSIGNES

APPLICATION: 2001-2011 FORD RANGER 2WD/4WD EXCLUDING STX MODELS
APP PART # 37-01250, 37-01255
OFF ROAD LIGHT BAR

ITEM	QUANTITY	DESCRIPTION	TOOLS NEEDED
1	1	LIGHT BAR	16MM SOCKET
2	2	M10 HEX HEAD BOLT	16MM WRENCH
3	4	M10 FLAT WASHERS	18MM SOCKET
4	2	M10 LOCK WASHERS	RATCHET
5	2	M10 HEX NUTS	TORQUE WRENCH

ANTI-SEIZE LUBRICANT MUST BE USED ON ALL STAINLESS STEEL FASTENERS TO PREVENT THREAD DAMAGE AND GALLING

1. Remove contents from box, verify if all parts listed are present and free from damage. Carefully read and understand all instructions before attempting installation.
2. Note: Vehicles equipped with factory tow hooks may retain them by swapping the driver and passenger side so the hooks bend toward each other. There are 3 bolts per side that are reused.
3. Using an 18mm socket remove the factory nuts from the back of the bolt plates shown in FIG. 1. Remove the bolt plates (the bolt plates are held in place by metal retaining rings, the bolt plates must be pried away from the retaining rings to remove them FIG. 2).
4. With assistance take the light bar and attach it where the bolt plates were. Attach the light bar using (2) M10 hex head bolts, and (2) M10 flat washers from the front of the light bar. From the rear of the light bar attach using (2) M10 flat washers, (2) M10 lock washers, and (2) M10 hex nuts FIG. 4. Do not fully tighten at this time.
5. Align and adjust the light bar as needed then tighten all hardware at this time. Torque all M10 hardware to 30-35 ft lbs

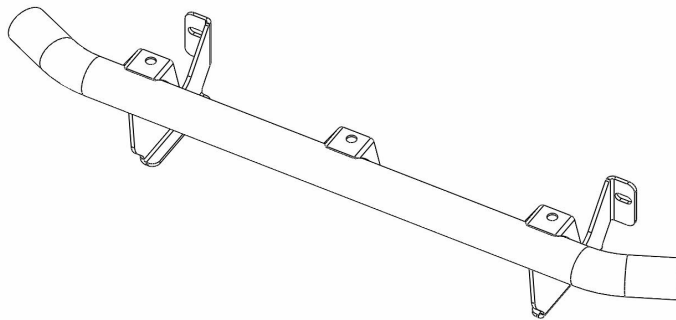

CARE INSTRUCTIONS

- REGULAR WAXING IS RECOMMENDED. DO NOT USE ANY TYPE OF POLISH OR WAX THAT MAY CONTAIN ABRASIVES
- STAINLESS STEEL PRODUCTS CAN BE CLEANED WITH MILD SOAP AND WATER. STAINLESS STEEL POLISH SHOULD BE USED TO POLISH SMALL SCRATCHES.
- GLOSS BLACK FINISHES SHOULD BE CLEANED WITH MILD SOAP AND WATER



Westin Automotive Products, Inc.
5200 N. Irwindale Ave. Suite 220
Irwindale, Ca. 91706

Thank You for choosing Westin products
For Additional installation assistance please call
Customer service (800) 793-7846
www.westinautomotive.com



FIG. 1



FIG. 2



FIG. 3

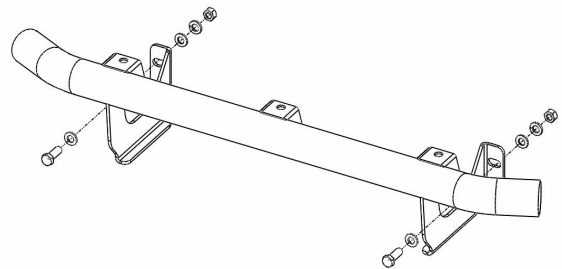

FIG. 4



INSTALLATION COMPLETE



Westin Automotive Products, Inc.
5200 N. Irwindale Ave. Suite 220
Irwindale, Ca. 91706

Thank You for choosing Westin products
For Additional installation assistance please call
Customer service (800) 793-7846
www.westinautomotive.com