



# INSTALLATION INSTRUCTIONS

## SPORTSMAN GRILLE GUARD

### APPLICATION:

1999-2004 Ford F-150/250LD 2WD

1999-2002 Ford Expedition 2WD

### PART NUMBER:

40-0485

AUTOMOTIVE PRODUCTS,

CONTENT			
ITEM	QUANTITY	DESCRIPTION	TOOLS NEEDED
1	1	GRILLE GUARD	13MM SOCKET
2,3	2	FRAME MOUNT BRACKETS, (2) DRIVER AND (3) PASSENGER	18MM SOCKET
4,5	2	TOP MOUNTING BRACKETS, (4) DRIVER AND (5) PASSENGER	18MM WRENCH
6,7	2	“L” TOP SUPPORT BRACKETS, (6) DRIVER AND (7) PASSENGER	PROVIDED HEX KEY TOOL
8	10	M12 HEX HEAD BOLTS	
9	10	M12 PREVAILING TORQUE HEX NUTS	RATCHET
10	20	M12 LARGE FLAT WASHERS	TORQUE WRENCH
11	2	M8 HEX HEAD BOLTS	
12	2	M8 PREVAILING TORQUE HEX NUTS	
13	4	M8 LARGE FLAT WASHERS	
14	2	M6 HEX SOCKET BUTTON HEAD SCREW	
15	2	M6 PREVAILING TORQUE HEX NUTS	
16	4	M6 LARGE FLAT WASHERS	

**ANTI-SEIZE LUBRICANT MUST BE USED ON ALL STAINLESS STEEL FASTENERS TO PREVENT THREAD DAMAGE AND GALLING**

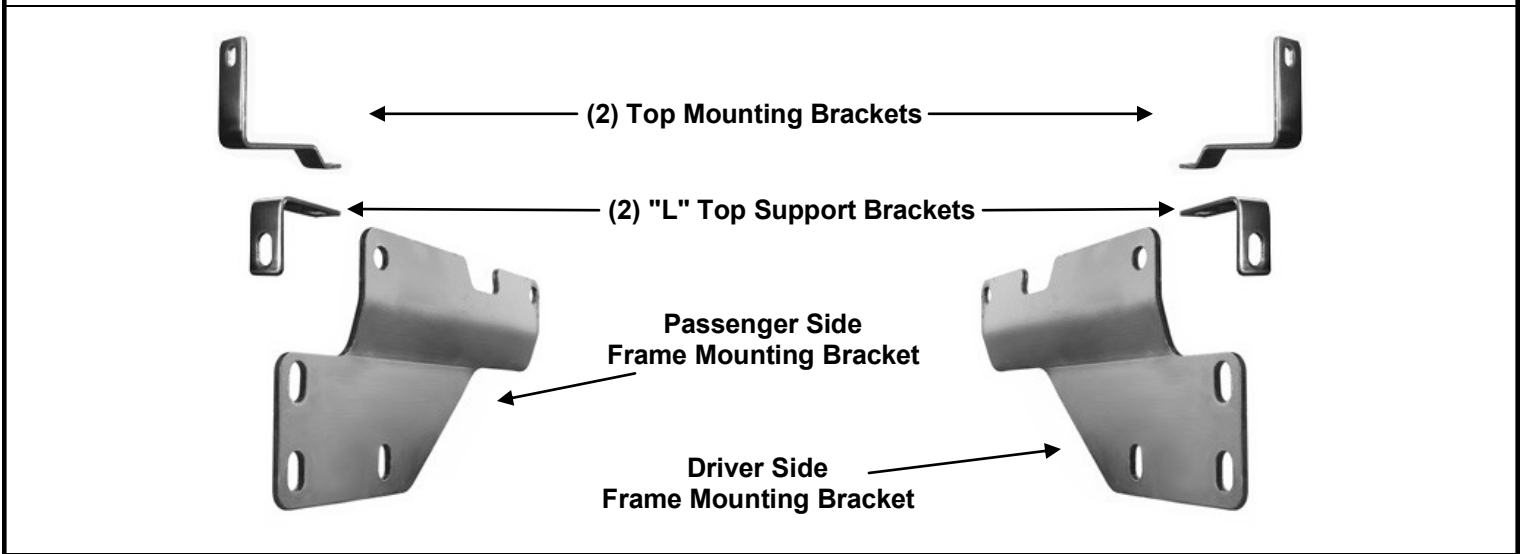

Westin Automotive Products, Inc.  
320 W. Covina Blvd  
San Dimas, Ca. 91773

## PROCEDURE

1. Remove contents from box, verify if all parts listed are present and free from damage. Carefully read and understand all instructions before attempting installation.  
**Failure to identify damage before installation could lead to a rejection of any claim.**
2. Depending on model and year, the plastic bumper cover or lower spoiler may need to be temporarily removed to access the end of the frame. Also, the cover or spoiler may need to be trimmed to clear the Frame Mounting Brackets. Cut the least amount of material possible to maintain the strength of the plastic components, **(Figures 3 & 12)**.
3. Starting on the driver side of the vehicle, hold the driver side Frame Bracket up against the outside of the frame. Match up the top mounting holes in the Bracket with the holes in the frame, **(Figure 1)**. Insert (1) M12 hex bolt with (1) M12 flat washer into the open end of the frame and out through the rear mounting hole, **(Figure 2)**. Attach the Bracket to the M12 bolt with (1) M12 flat washer and (1) M12 nylon lock nut, **(Figure 3)**. Leave loose at this time. Repeat this procedure to bolt the Bracket to the forward mounting location at the end of the frame. Snug but do not fully tighten the hardware at this time.
4. Repeat **Step 3** to install the passenger side Frame Mounting Bracket.
5. Next, remove the factory hex bolt located on the back of the front bumper securing the bumper to the top of the bumper bracket, **(Figure 4)**. Select (1) "L" Top Support Bracket and attach it to the back of the bumper bracket using the factory hex bolt, **(Figure 5)**. Snug but do not tighten hardware at this time. Repeat this Step to install the passenger side "L" Top Support Bracket.
6. Select (1) Top Mounting Bracket. Apply a section of Adhesive Backed Foam Tape to the bottom of the Bracket to protect the finish on the top of the bumper cover, **(Figure 6)**. Insert the Bracket through the opening in the bottom of the grille, **(Figures 7 & 8)**. **NOTE:** It is also recommended to cover the bumper with masking tape to prevent damage to finish during Grille Guard installation.
7. Bolt the Top Mounting Bracket to the "L" Top Support Bracket installed in **Step 5** using (1) M8 hex bolt, (2) M8 flat washers and (1) M8 nylon lock nut, **(Figures 9A & 9B)**. Do not tighten at this time. Repeat this step for passenger side Top Bracket installation.
8. With assistance, position the mounting tabs on the Grille Guard up to the outside of the Frame Mounting Brackets and bolt together with the included (6) M12 hex bolts, (12) M12 flat washers and (6) M12 nylon lock nuts, **(Figure 10)**. Snug but do not tighten hardware at this time.
9. Move the Grille Guard into position and line up the Top Mounting Brackets with the mounting slots in the back of the cross bar. Bolt the Top Mounting Brackets to the cross bar with (2) M6 button head bolts, (4) M6 flat washers and (2) M6 nylon lock nuts, **(Figure 11)**.
10. With the hood open, push the Grille Guard back until it is upright. Align, center and adjust the Grille Guard properly. Do not tighten the hardware securing the Grille Guard to the Brackets. Carefully close the hood and check for clearance between the Top Brackets and the factory grille insert. Once all Brackets have been checked for clearance, tighten all hardware securing the Brackets to the vehicle only, including the hardware behind the bumper and Mounting Brackets. Remove the Grille Guard. Reinstall the lower bumper cover removed in **Step 2**. Trim the bumper cover to clear Brackets as necessary. Reinstall the Grille Guard as described in **Steps 8 & 9** and fully tighten all hardware, **(Figure 12)**.
11. Do periodic inspections to the installation to make sure that all hardware is secure and tight.



Westin Automotive Products, Inc.  
320 W. Covina Blvd  
San Dimas, Ca. 91773

Driver Side Installation Pictured

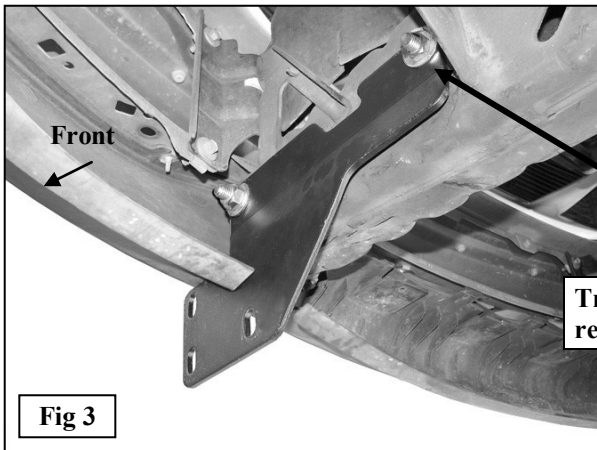
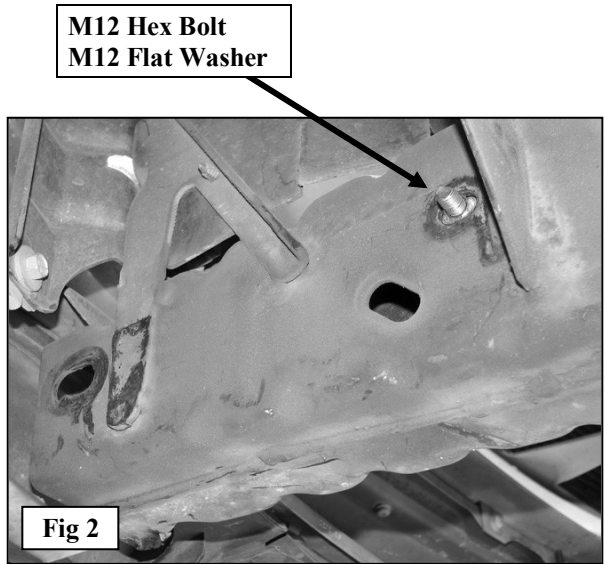
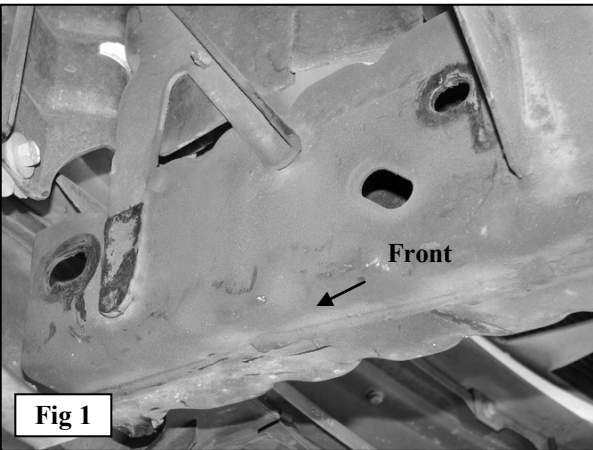

- (2) M12 Hex Bolts
- (4) M12 Flat Washers
- (2) M12 Nylon Lock Nuts

Trimming to the plastic bumper may be required for Mounting Bracket clearance.

Remove factory hex bolt.

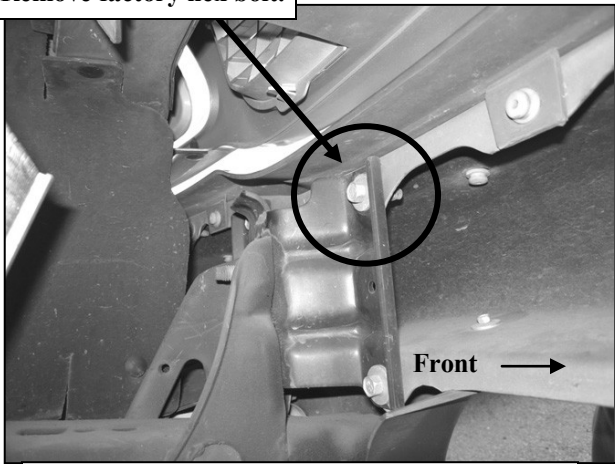

Use factory hex bolt to attach "L" Top Support Bracket.

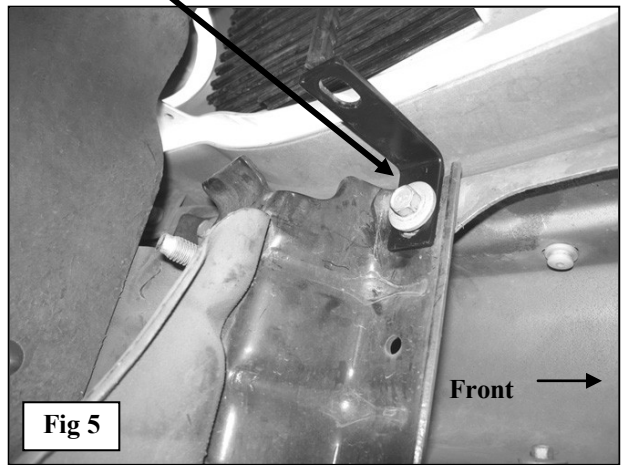

Westin Automotive Products, Inc.  
320 W. Covina Blvd  
San Dimas, Ca. 91773

Thank you for choosing Westin products  
for additional installation assistance please call  
Customer Service (800) 793-7846  
www.westinautomotive.com

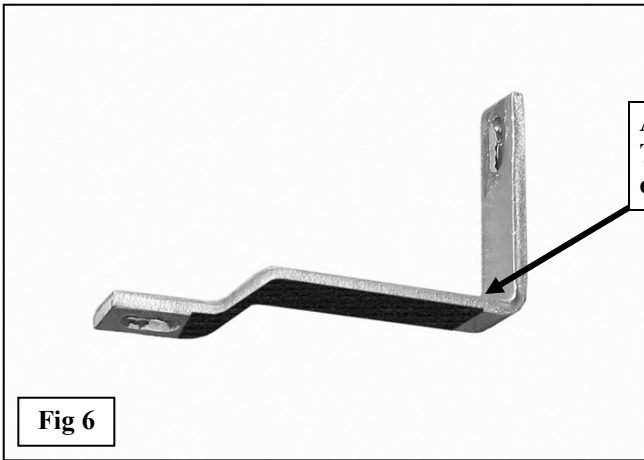

Apply supplied Adhesive Backed Foam Tape to Top Brackets to protect finish on bumper cover. Cut to fit as needed.

Fig 6

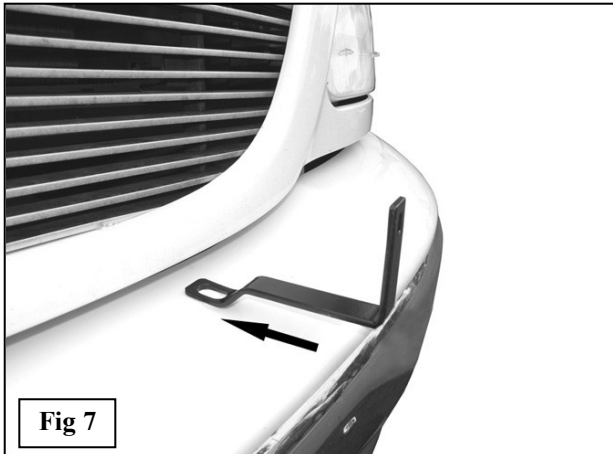

Fig 7

Insert Top Mounting Bracket between grille and top of bumper.

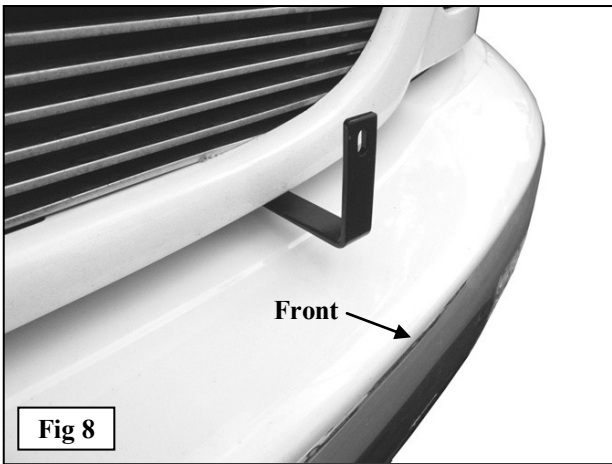
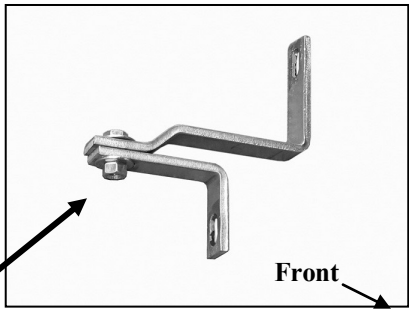

Fig 8

Front



Front

Fig 9B

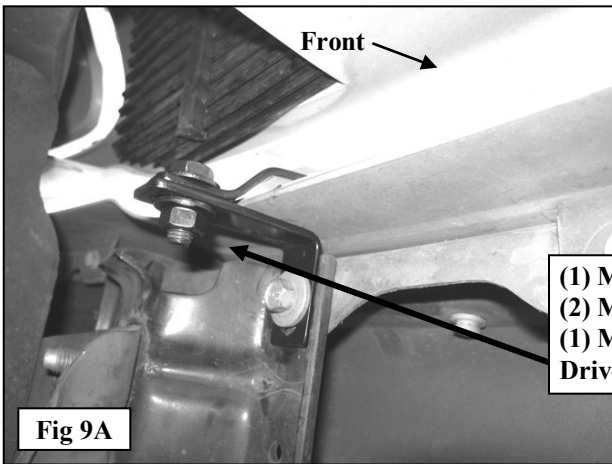

Fig 9A

Front

(1) M8 Hex Bolt  
 (2) M8 Flat Washers  
 (1) M8 Nylon Lock Nut  
 Driver side-back of bumper pictured.



Westin Automotive Products, Inc.  
 320 W. Covina Blvd  
 San Dimas, Ca. 91773



- (3) M12 Hex Bolts
- (6) M12 Flat Washers
- (3) M12 Nylon Lock Nuts

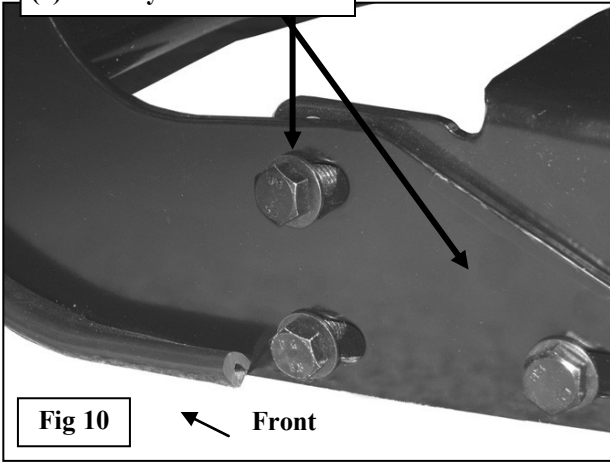

- (1) M6 Button Head Bolt
- (2) M6 Flat Washers
- (1) M6 Nylon Lock Nut

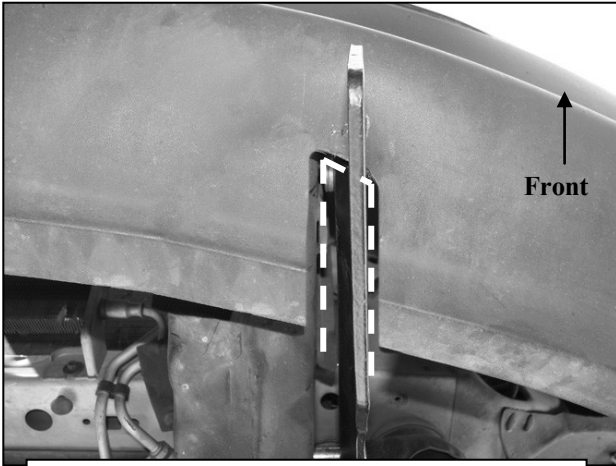
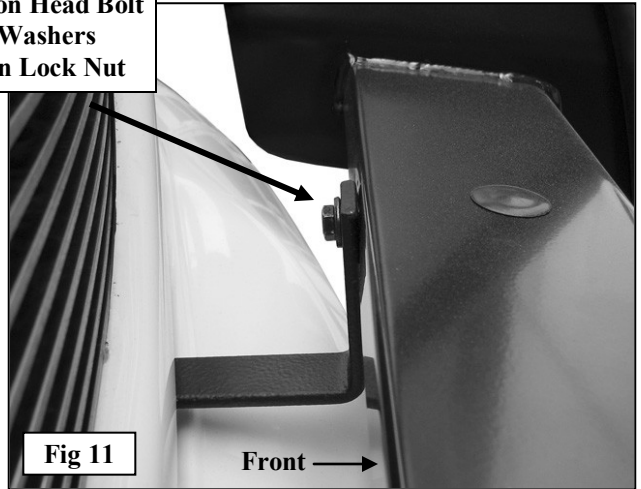

(Fig 12) Driver side Bracket installation pictured from below bumper cover. Cut cover as necessary to clear Brackets.

**INSTALLATION COMPLETE**



**CARE INSTRUCTIONS**

- REGULAR WAXING IS RECOMMENDED. DO NOT USE ANY TYPE OF POLISH OR WAX THAT MAY CONTAIN ABRASIVES.
- STAINLESS STEEL PRODUCTS CAN BE CLEANED WITH MILD SOAP AND WATER. STAINLESS STEEL POLISH SHOULD BE USED TO POLISH SMALL SCRATCHES.
- GLOSS BLACK FINISHES SHOULD BE CLEANED WITH MILD SOAP AND WATER.



Westin Automotive Products, Inc.  
320 W. Covina Blvd  
San Dimas, Ca. 91773

Thank you for choosing Westin products  
for additional installation assistance please call  
Customer Service (800) 793-7846

[www.westinautomotive.com](http://www.westinautomotive.com)

# Westin

SIGNATURE OF QUALITY

AUTOMOTIVE PRODUCTS, INC.



## WARNING



Failure to follow these instructions could lead to death, personal injury, and / or property damage.

### FASTENERS:

All Westin supplied fasteners must be utilized and installed in accordance with the installation instructions and apply torque to the specifications as defined. **DOUBLE CHECK ALL FASTENERS BEFORE INITIAL USE, AND PERIODICALLY IN THE FUTURE TO ENSURE PROPER FUNCTION AND SAFETY.**

### DRILLING:

Most Westin products do not require drilling for installation. If drilling is defined as required, use caution when drilling a vehicle. **FAILURE TO REVIEW AN AREA TO BE DRILLED MAY RESULT IN PERSONAL INJURY AND/OR INJURY TO OTHERS AS WELL AS VEHICLE DAMAGE.**

### EYE PROTECTION:

**ALWAYS WEAR SAFETY GLASSES OR GOGGLES DURING THE INSTALLATION PROCESS TO AVOID PERSONAL INJURY.**

### MAXIMUM TOWING/CARRYING CAPACITY:

The Westin Receiver Hitches will have a visible tow rating label affixed directly on the product. User should never exceed the vehicle manufacturers maximum tow and weight rating regardless of the capacity of the hitch. **FAILURE TO FOLLOW THESE GUIDELINES WILL VOID THE WESTIN WARRANTY AND MAY RESULT IN PERSONAL INJURY AND/OR INJURY TO OTHERS AS WELL AS VEHICLE DAMAGE.**

**Westin**  
SIGNATURE OF QUALITY

Westin Automotive Products, Inc.  
320 W. Covina Blvd  
San Dimas, Ca. 91773