



INSTRUCTIONS—INSTRUCCIONES—CONSIGNES

APPLICATION: 2011-UP DODGE DURANGO
PART # 37-03650, 37-03655
OFF ROAD LIGHT BAR



AUTOMOTIVE PRODUCTS, INC.

ITEM	QUANTITY	DESCRIPTION	TOOLS NEEDED
1	1	LIGHT BAR	17MM SOCKET
2,3	2	MOUNTING BRACKET 2(DRIVERS SIDE), 3(PASSENGER SIDE)	17MM WRENCH
4	4	M10 HEX HEAD BOLTS (YELLOW ZINC)	TORQUE WRENCH
5	4	M10 FLAT WASHERS (YELLOW ZINC)	10MM SOCKET
5	4	M10 LOCK WASHERS (YELLOW ZINC)	13MM SOCKET
6	4	M10 HEX HEAD BOLTS (STAINLESS STEEL)	
7	8	M10 FLAT WASHERS (STAINLESS STEEL)	
8	4	M10 LOCK WASHERS (STAINLESS STEEL)	
9	4	M10 HEX NUTS (STAINLESS STEEL)	

ANTI-SEIZE LUBRICANT MUST BE USED ON ALL STAINLESS STEEL FASTENERS TO PREVENT THREAD DAMAGE AND GALLING

1. Remove all contents from box, verify all parts listed are present and free from damage. Carefully read and understand all instructions before attempting installation.
2. Determine if the vehicle is equipped with or without factory tow hooks, (Figure 1). Remove the plastic splash guard, (Figure 2). Pay close attention to the type and location of all factory hardware for easier reinstallation. If vehicle is equipped with tow hooks, remove both tow hooks and skip ahead to Step 4. NOTE: Tow hooks cannot be reinstalled with the Light Bar.
3. On vehicles without factory tow hooks: Remove the (3) clips fastening the air deflector to the bottom of the cross member, (Figure 4). Pull the bumper cover forward for access and pull the air deflector out from behind the bumper cover, (Figure 5). Release the clips securing the (2) block off covers to the ends of the air deflector, (Figure 6). Remove the (2) block offs. Reinstall the air deflector using the factory hardware. Reinstall the bumper cover.
4. Select the driver side Mounting Bracket. Line up the (2) slots in the bracket with the (2) threaded holes in the bottom of the frame channel, (Figure 7). Bolt the Bracket to the frame channel with (2) M10 Hex Bolts (yellow zinc), (2) M10 Flat Washers (yellow zinc) and (2) M10 Lock Washers (yellow zinc), (Figure 8). Do not tighten hardware at this time. Repeat this step for passenger side Bracket installation.
5. With assistance, hold the Light Bar up to the inside of the Mounting Brackets. Attach the Light Bar to the Mounting Brackets with the included (4) M10 Hex Bolts (stainless steel), (8) M10 Flat Washers (stainless steel), (4) M10 Lock Washers (stainless steel) and (4) M10 Hex Nuts (stainless steel), (Figure 10).
6. Align and adjust the Light Bar and tighten all hardware. Reinstall the splash guard removed in Step 4, (Figure 2).
7. Torque all M10 fasteners to 35-40 ft lbs, and stainless fasteners to 25-30 ft lbs



Westin Automotive Products, Inc.
5200 N. Irwindale Ave. Ste 220
Irwindale, Ca 91706

Thank You for choosing Westin products
For additional installation assistance please call
Customer Service (800) 793-7846
www.westinautomotive.com

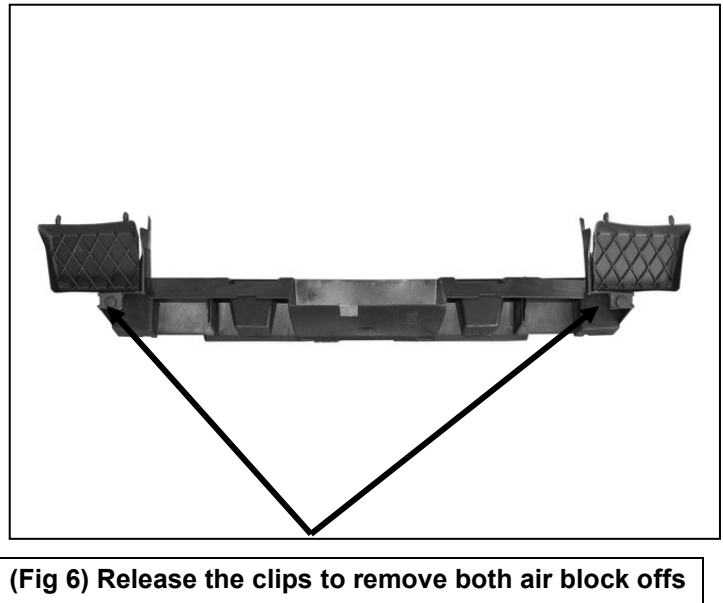
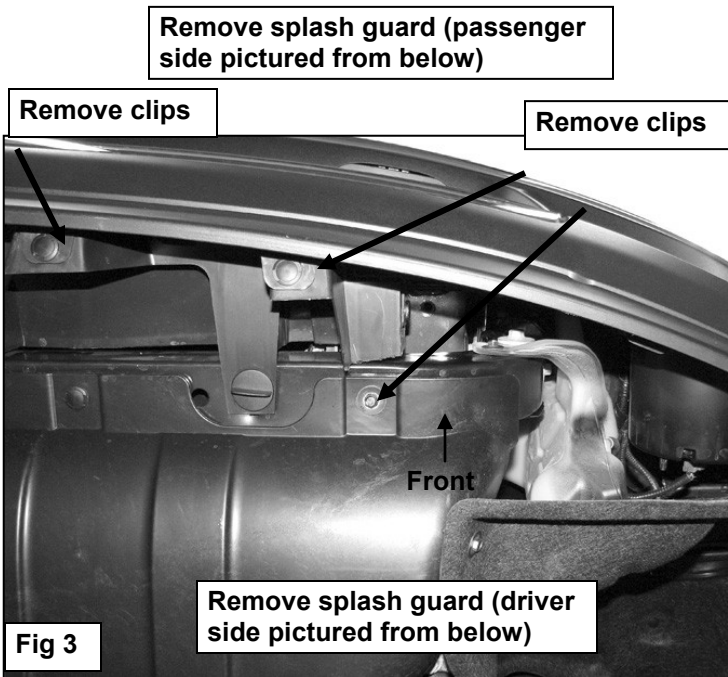
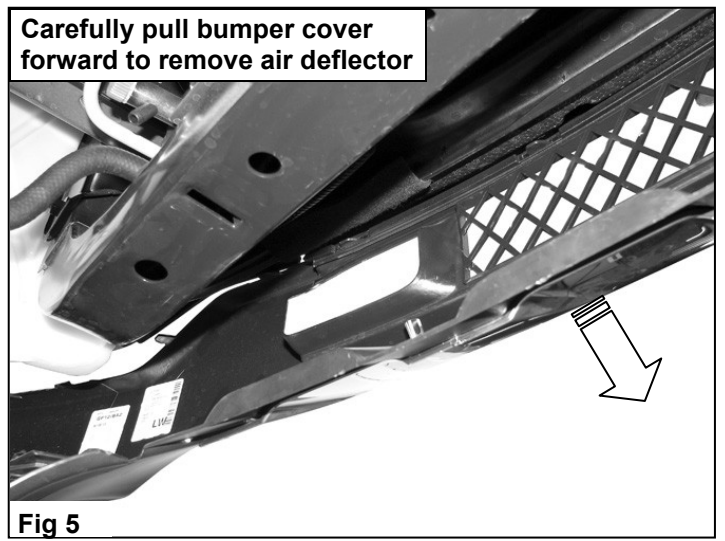
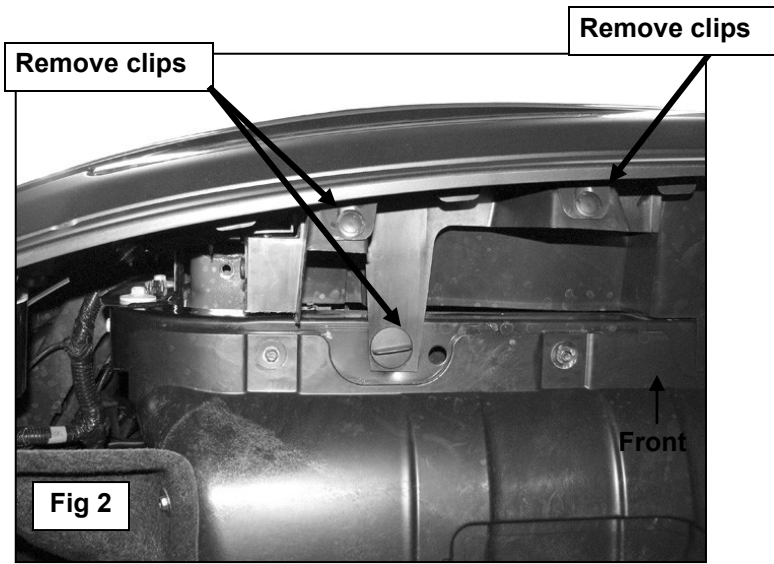
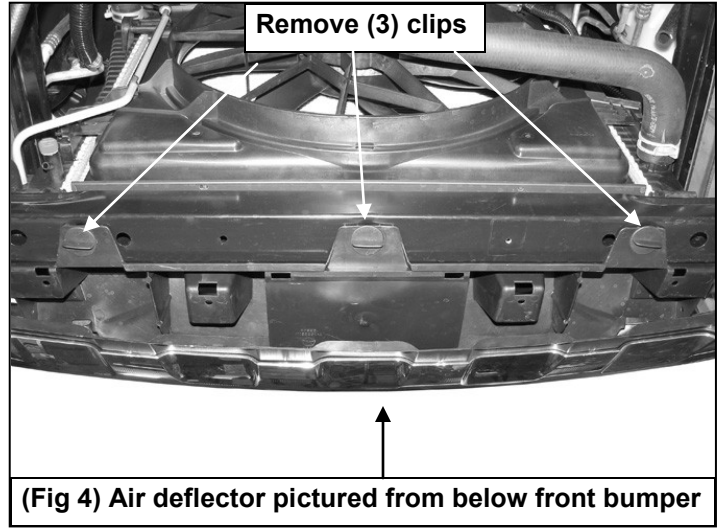
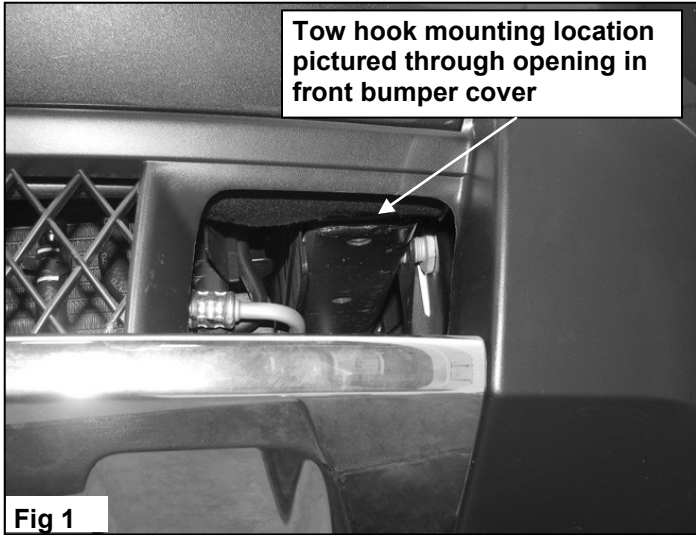

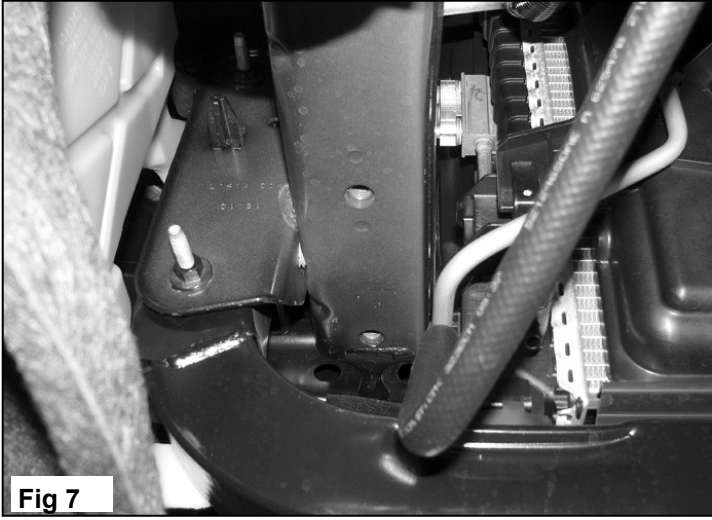

Fig 7

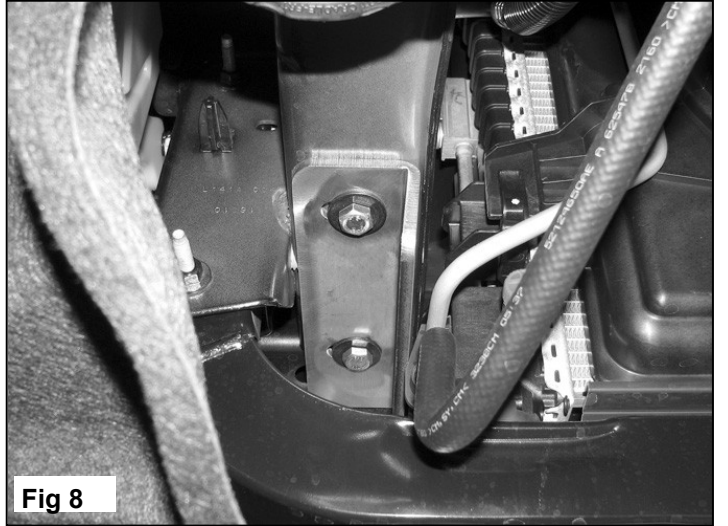

Fig 8



Fig 9

