



INSTALLATION INSTRUCTIONS

AUTOMOTIVE PRODUCTS,

ULTIMATE BULL BAR
APPLICATION:
2005-2015 Toyota Tacoma
PART NUMBER:

32-1600, 32-1605, 32-1600L, 32-1605L

ITEM	QUANTITY	DESCRIPTION	TOOLS NEEDED
1	1	ULTIMATE BULL BAR	9/16" SOCKET
2,3	2	BRACKET, PASSENGER (2) AND DRIVER (3)	9/16" WRENCH
4	2	PLASTIC PLUG	17MM SOCKET
5	4	RUBBER BUMPER	14MM DEEP SOCKET
6	4	3/8-16 X 1.25" HEX HEAD BOLT	RATCHET
7	8	3/8" SAE FLAT WASHER	TORQUE WRENCH
8	4	3/8" LOCK WASHER	
9	4	3/8-16 HEX NUT	
10	2	3/8-16 X 4.50" HEX HEAD BOLT	
11	2	3/8" SAE FLAT WASHER	
12	2	3/8" USS FLAT WASHER	
13	2	3/8" LOCK WASHER	
14	2	3/8-16 HEX NUT	
15	4	SPACER WASHER	
16	1	LED WIRING HARNESS (09-12000-1)	

ANTI-SEIZE LUBRICANT MUST BE USED ON ALL STAINLESS STEEL FASTENERS TO PREVENT THREAD DAMAGE AND GALLING

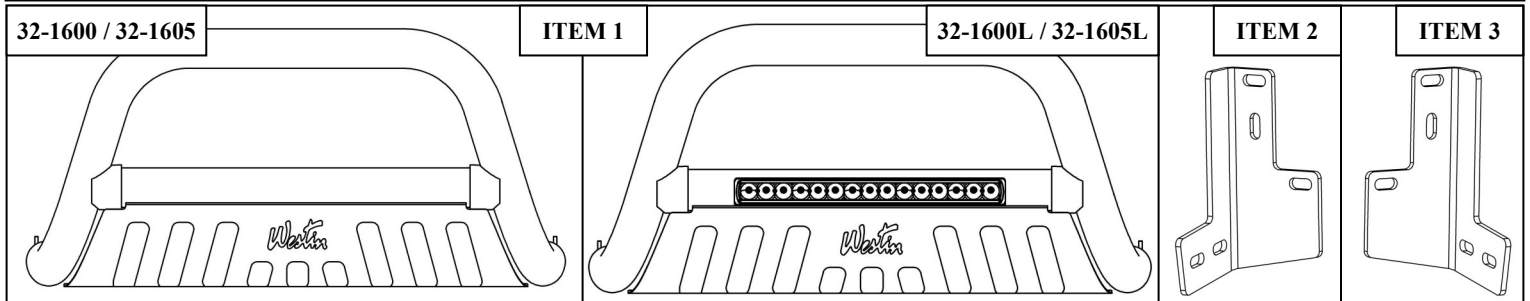

CARE INSTRUCTIONS

- REGULAR WAXING IS RECOMMENDED. DO NOT USE ANY TYPE OF POLISH OR WAX THAT MAY CONTAIN ABRASIVES.
- STAINLESS STEEL PRODUCTS CAN BE CLEANED WITH MILD SOAP AND WATER. STAINLESS STEEL POLISH SHOULD BE USED TO POLISH SMALL SCRATCHES.
- GLOSS BLACK FINISHES SHOULD BE CLEANED WITH MILD SOAP AND WATER.



Westin Automotive Products, Inc.
 320 W. Covina Blvd
 San Dimas, Ca. 91773

Thank you for choosing Westin products
 for additional installation assistance please call
 Customer Service (800) 793-7846

PROCEDURE

1. Remove contents from box, verify if all parts listed are present and free from damage.

Carefully read and understand all instructions before attempting installation.

Failure to identify damage before installation could lead to a rejection of any claim.

NOTE: It may be necessary to remove/relocate front license plate and license plate bracket. It is not required, but strongly recommended. If local/state laws requires a license plate, license plate relocation kit 32-0055 is available.

2. Determine passenger and driver brackets. From underneath vehicle, remove tow hooks. Tow hooks will not be reinstalled. Locate the two studs that hold the bumper support to the frame. Remove the nuts and install mount bracket onto the studs and replace factory nuts. Insert the 3/8-16 x 4.50" bolt through the frame and into the mount bracket. Secure with 3/8" yellow zinc fasteners as shown. See **Figure 2**.
3. Attach Bull Bar to mount brackets using 3/8" stainless steel fasteners. Level and adjust Bull Bar as desired and tighten all fasteners. Recommended torque values are 26 Ft. Lbs. for 3/8" yellow zinc fasteners, 17 Ft. Lbs. for 3/8" stainless steel fasteners and 32 Ft. Lbs. for M10 bumper nuts.
4. **For part number 32-1605L:** Refer to **Page 3** for wiring instructions. Loosen M8 hardware to adjust the LED light in bull bar or to remove it in order to replace it. See **Figure 3** for location of M8 hardware.

Light Installation (32-1600/32-1605): Insert threaded stud on base of the light through hole in cross tube. Using a ratchet, extension and socket for correct size of nut supplied, insert through large clearance hole in bottom of cross tube. Thread nut and washers on stud and tighten. See **Figure 1**. **Note:** A short socket, not a deep well works best to get the nut started.

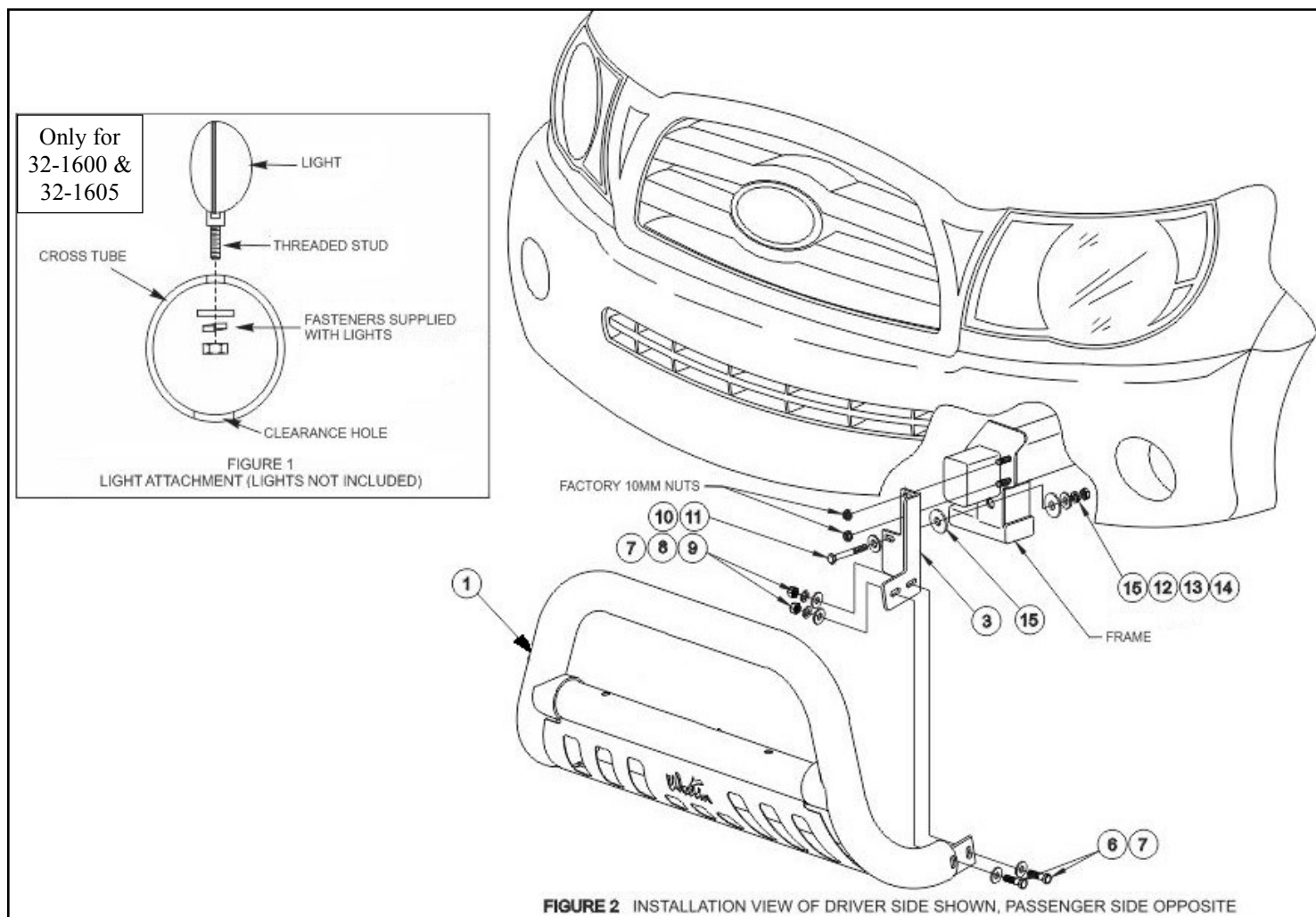

Westin Automotive Products, Inc.
320 W. Covina Blvd
San Dimas, Ca. 91773

WIRING INSTRUCTIONS FOR 32-1605L:

WESTIN recommends using a professional for this installation.

CAUTION:

1. Disconnect ground connection from battery (-) to avoid accidental short circuits before attempting to connect electrical wires.
2. When running wires, avoid areas of excessive heat, vibration, pinch or rotation when securing harness to vehicle.
3. Always use a fused (+) positive supply source.
4. This light becomes hot under continuous use. Do not remove or touch the casting for at least 30 minutes after the lamp has been turned off.

Refer to Figure 4.

1. Locate wiring harness and mount the switch in a convenient location where it is easily accessible from the drivers seat.
Note: *The switch will need to be removed from the wiring harness so that the rest of the harness can be routed from the engine bay to the cabin.*
2. Route the wiring harness wire, specifically the fuse and relay, from the positive battery terminal along the firewall's existing wire routes. **Note:** *Tape as necessary to correct slack.*
3. Secure the relay by either drilling or using a pre-existing bolt along the chassis that is not connected to any other wire.
4. Run the switch harness through the firewall preferably through the pre-existing rubber plug that is used to run the OEM wiring harness from the engine bay to fuse box. **Note:** *Reconnect the switch to the wiring harness.*
5. Place the LED plug wire along the fender chassis where it will not get pinched and away from any moving parts (fan, pulleys etc.).
6. Run the attached wire from the LED Light Bar as previously mentioned away from any moving parts.
7. Connect both ends of wiring connectors from LED light bar and wiring harness.
8. Re-connect battery terminals, attach the Red (+) wire to battery positive, and the black (-) wire to ground. **Note:** *Add dielectric grease (not supplied).*
9. Turn on the switch to make sure if the lamp works. If not, please check carefully if the wiring installation is correct.

M8 hardware attaches LED light onto bull bar.

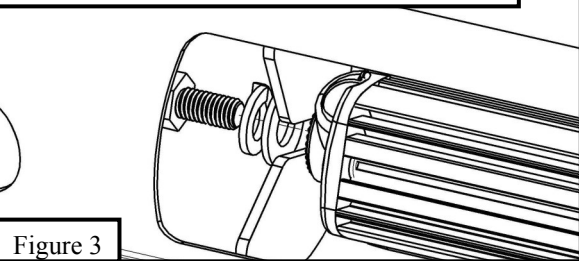

Figure 3

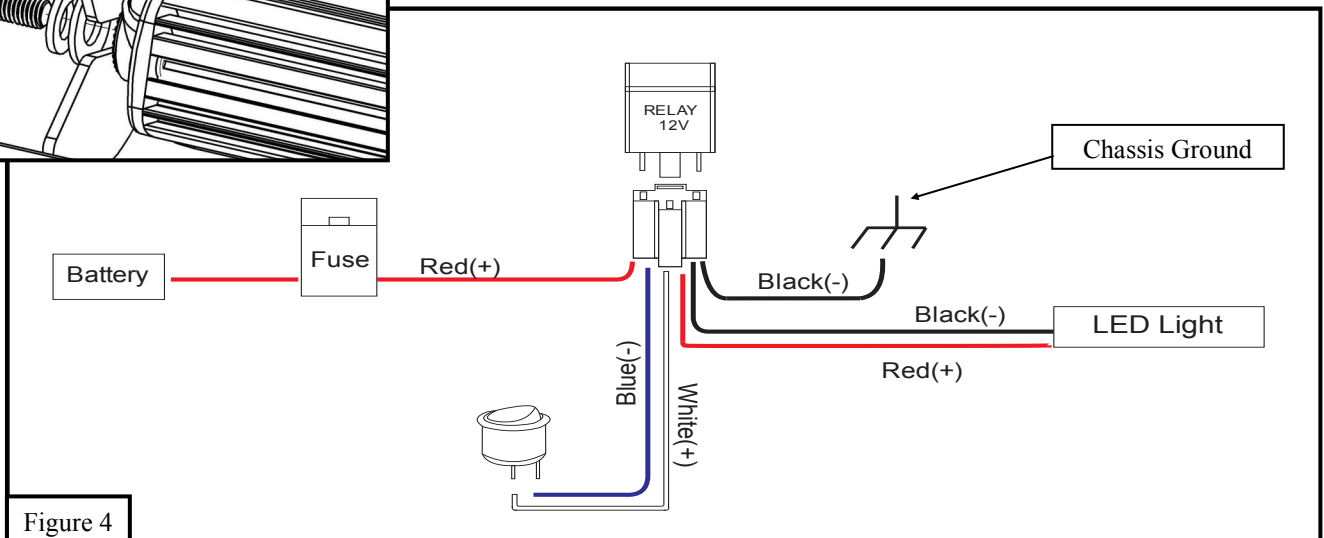

Figure 4



Westin Automotive Products, Inc.
320 W. Covina Blvd
San Dimas, Ca. 91773

Westin

SIGNATURE OF QUALITY

AUTOMOTIVE PRODUCTS, INC.



WARNING



Failure to follow these instructions could lead to death, personal injury, and / or property damage.

FASTENERS:

All Westin supplied fasteners must be utilized and installed in accordance with the installation instructions and apply torque to the specifications as defined. **DOUBLE CHECK ALL FASTENERS BEFORE INITIAL USE, AND PERIODICALLY IN THE FUTURE TO ENSURE PROPER FUNCTION AND SAFETY.**

DRILLING:

Most Westin products do not require drilling for installation. If drilling is defined as required, use caution when drilling a vehicle. **FAILURE TO REVIEW AN AREA TO BE DRILLED MAY RESULT IN PERSONAL INJURY AND/OR INJURY TO OTHERS AS WELL AS VEHICLE DAMAGE.**

EYE PROTECTION:

ALWAYS WEAR SAFETY GLASSES OR GOGGLES DURING THE INSTALLATION PROCESS TO AVOID PERSONAL INJURY.

MAXIMUM TOWING/CARRYING CAPACITY:

The Westin Receiver Hitches will have a visible tow rating label affixed directly on the product. User should never exceed the vehicle manufacturers maximum tow and weight rating regardless of the capacity of the hitch. **FAILURE TO FOLLOW THESE GUIDELINES WILL VOID THE WESTIN WARRANTY AND MAY RESULT IN PERSONAL INJURY AND/OR INJURY TO OTHERS AS WELL AS VEHICLE DAMAGE.**

Westin
SIGNATURE OF QUALITY

Westin Automotive Products, Inc.
320 W. Covina Blvd
San Dimas, Ca. 91773