

INSTALLATION INSTRUCTIONS

RUNNING BOARD MOUNT KIT



APPLICATION:

2007-2013 Chevrolet Silverado / GMC Sierra 1500 Crew Cab

2008-2014 Chevrolet Silverado / GMC Sierra 2500/3500HD Crew Cab

PART NUMBER:

27-1755

ITEM	QUANTITY	DESCRIPTION	TOOLS NEEDED
1	5	MOUNT BRACKET	13MM WRENCH
2	1	THIN MOUNTING BRACKET	13MM SOCKET
3	12	M8 HEX HEAD BOLT	RATCHET
4	6	M8 HEX NUT	TORQUE WRENCH
5	2	M8 EXTRUDED U-NUT	
6	12	M8 SQUARE HEAD BOLT	
7	30	M8 FLAT WASHER	
8	12	M8 LOCK WASHER	
9	12	M8 LOCK NUT	

ANTI-SEIZE LUBRICANT MUST BE USED ON ALL STAINLESS STEEL FASTENERS TO PREVENT THREAD DAMAGE AND GALLING

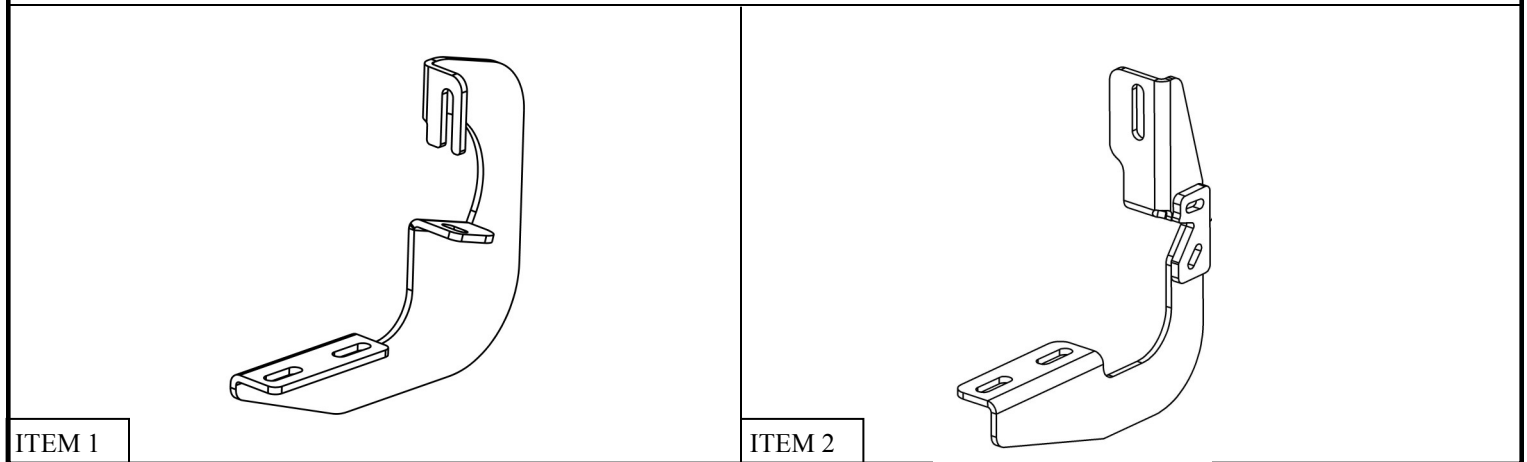

ITEM 1

ITEM 2

PROCEDURE

1. Remove contents from box, verify if all parts listed are present and free from damage.
Carefully read and understand all instructions before attempting installation.
Failure to identify damage before installation could lead to a rejection of any claim.

CARE INSTRUCTIONS

- REGULAR WAXING IS RECOMMENDED. DO NOT USE ANY TYPE OF POLISH OR WAX THAT MAY CONTAIN ABRASIVES.
- STAINLESS STEEL PRODUCTS CAN BE CLEANED WITH MILD SOAP AND WATER. STAINLESS STEEL POLISH SHOULD BE USED TO POLISH SMALL SCRATCHES.
- GLOSS BLACK FINISHES SHOULD BE CLEANED WITH MILD SOAP AND WATER.



Westin Automotive Products, Inc.
320 W. Covina Blvd
San Dimas, Ca. 91773

Thank you for choosing Westin products
for additional installation assistance please call
Customer Service (800) 793-7846

www.westinautomotive.com

- Attach mounting brackets as shown. See Figures 1, 4, 5, 6, and 7. For late model (2011-2014) diesel trucks see Page 4. See Page 3 for bracket locations.

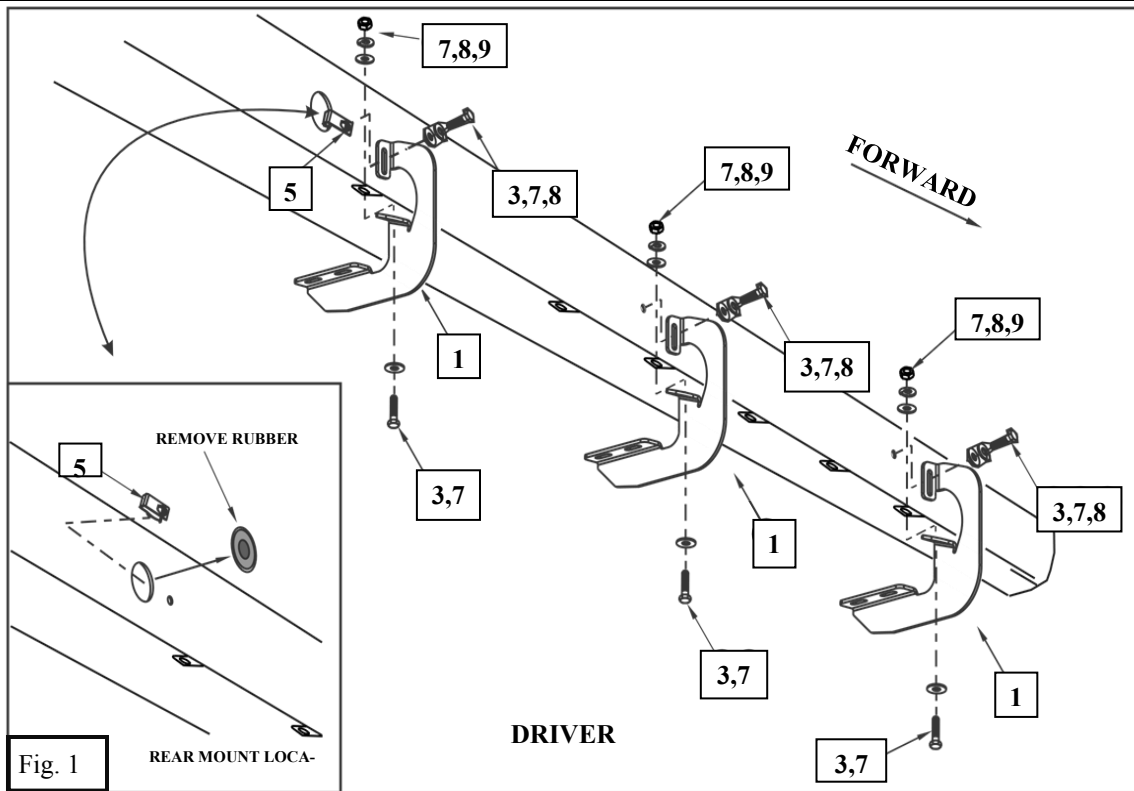

- Insert square head bolts as shown (3 per slot, 6 per board). See Figures 2 and 3.
- Make sure board and brackets are properly aligned and tighten fasteners. Recommended torque value is 15-18 ft-lbs for M8 fasteners.

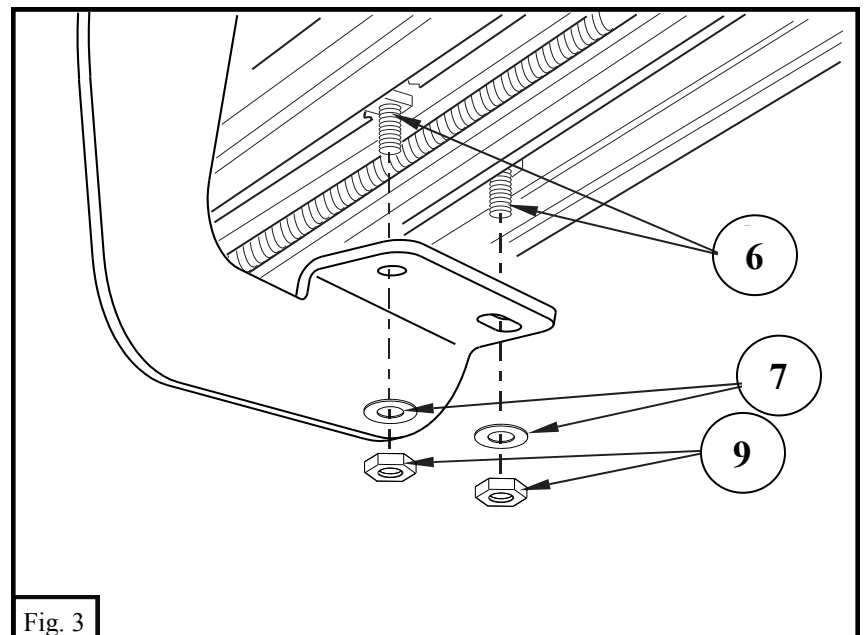
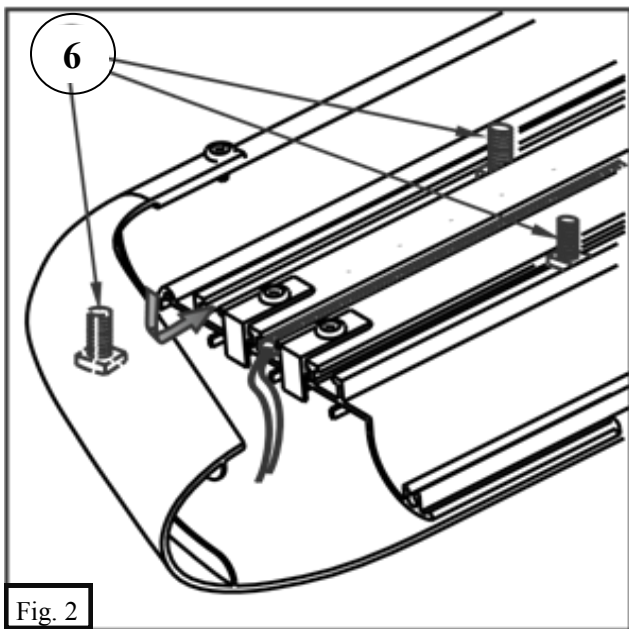

ALL 2011 - 2014 DIESEL SILVERADO/SIERRA: EXTENDED AND CREW CAB



FRONT PASSENGER SIDE

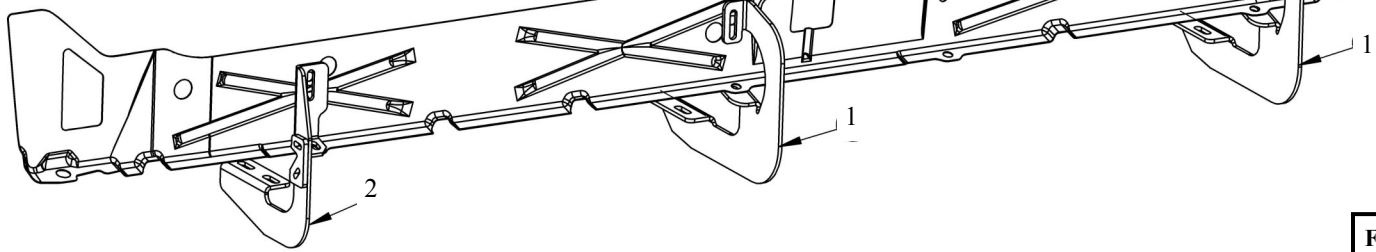
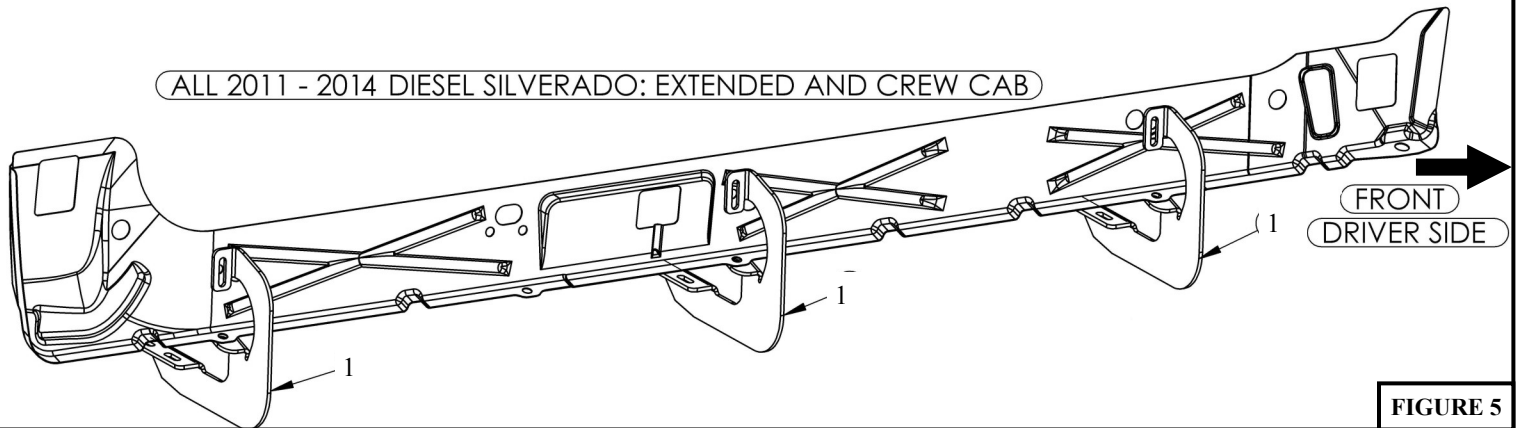

FIGURE 4

ALL 2011 - 2014 DIESEL SILVERADO: EXTENDED AND CREW CAB



FRONT DRIVER SIDE

FIGURE 5

ALL 2007 - 2010 DIESEL & 2007 - 2014 GAS SILVERADO/SIERRA: EXTENDED AND CREW CAB



FRONT PASSENGER SIDE

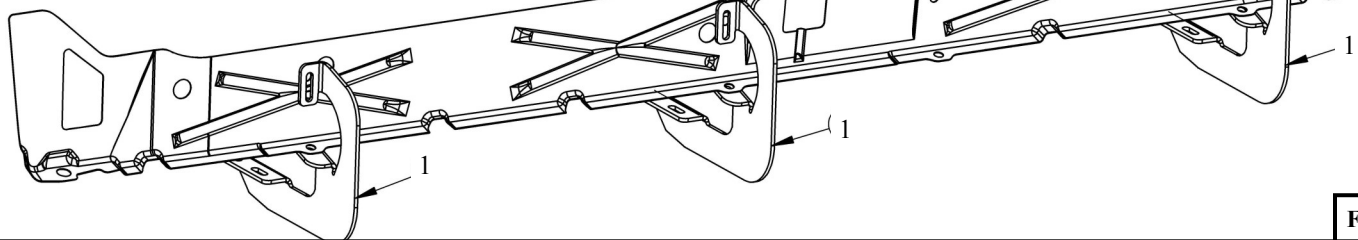
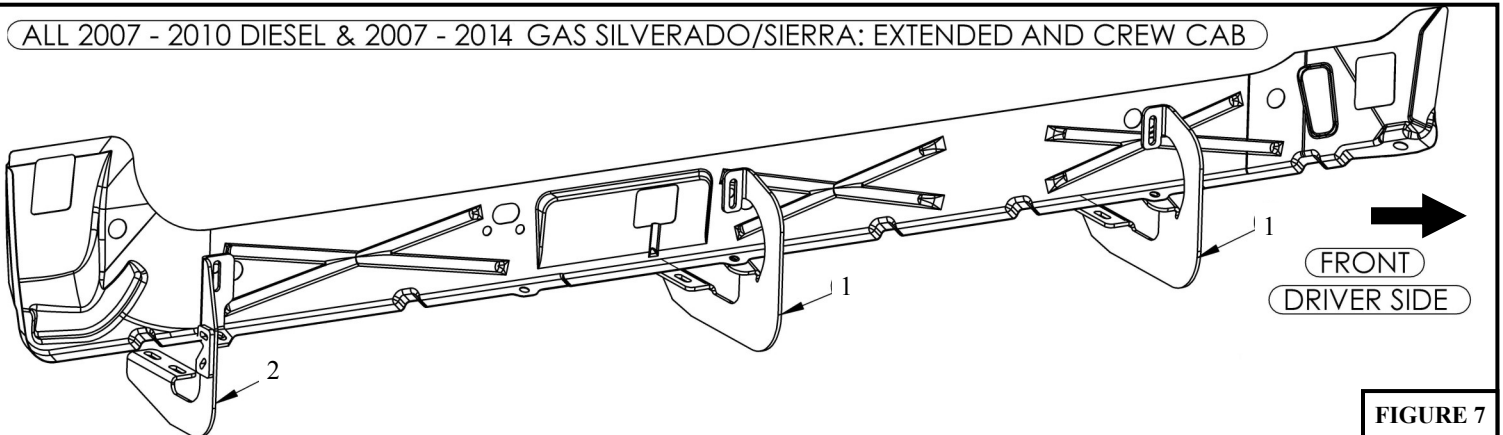

FIGURE 6

ALL 2007 - 2010 DIESEL & 2007 - 2014 GAS SILVERADO/SIERRA: EXTENDED AND CREW CAB



FRONT DRIVER SIDE

FIGURE 7



Westin Automotive Products, Inc.
320 W. Covina Blvd
San Dimas, Ca. 91773

Thank you for choosing Westin products
for additional installation assistance please call
Customer Service (800) 793-7846

www.westinautomotive.com

DATE: 07/26/18

FOR DIESEL EXHAUST FLUID TANK EQUIPPED APPLICATIONS, THE TANK MUST BE LOWERED TO INSTALL THE PASSENGER SIDE FRONT MOUNTING BRACKET.

1. Remove the D.E.F. tank cover by removing the three fasteners along the front edge, then lift the cover off the hooks in the rear and push it towards the frame.
2. Disconnect the fill hose from the front of the tank. Fig 1
3. Remove the support strap closest to the front of the vehicle by removing the bolt between the tank and rocker panel. The strap then can be unhooked and dropped from the rear.
4. Loosen the rear strap to drop the front of the tank approximately 4". Fig 2
5. Install the passenger side diesel bracket (Item 2) by using the hardware shown in Fig 3. Check page 3 for correct placement of the diesel bracket. Additional clearance may be had by removing the two fasteners holding the front upper strap to the frame.
6. Reinstall the DEF tank and support straps.
7. Trimming of the D.E.F. cover is recommended before attempting to re-install it.

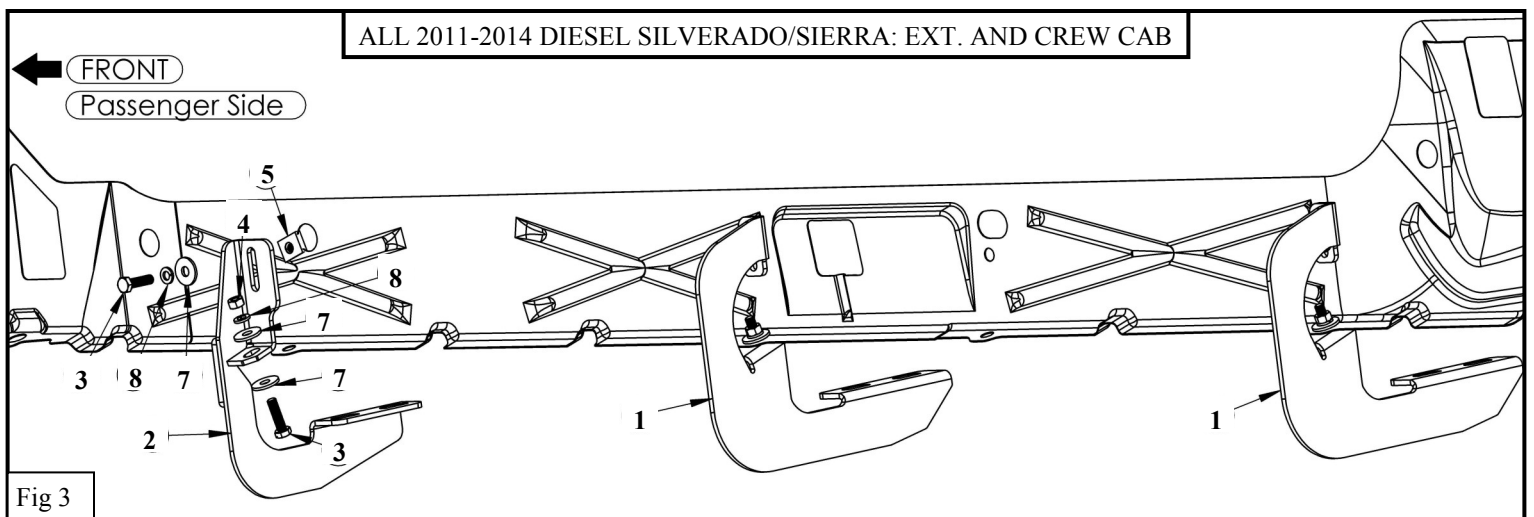
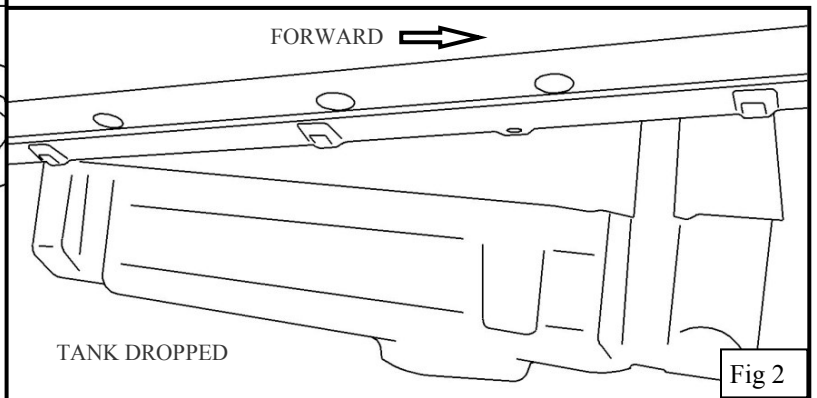
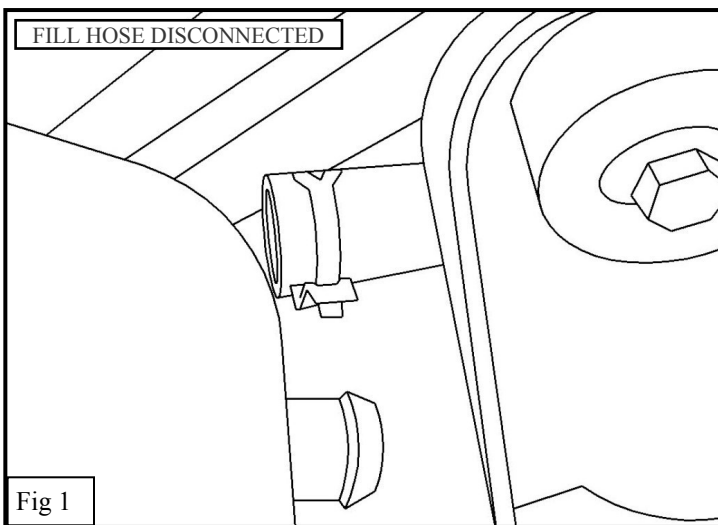

INSTALLATION COMPLETE



WESTIN

Westin Automotive Products, Inc.
320 W. Covina Blvd
San Dimas, Ca. 91773

P.N.: 75-0768-Rev1

ECO #: W18-0015

5

Thank you for choosing Westin products
for additional installation assistance please call
Customer Service (800) 793-7846
www.westinautomotive.com

DATE: 07/26/18



WARNING



Failure to follow these instructions could lead to death, personal injury, and / or property damage.

Failure to follow these instructions could lead to death, personal injury, and / or property damage.

FASTENERS:

All Westin supplied fasteners must be utilized and installed in accordance with the installation instructions and apply torque to the specifications as defined. **DOUBLE CHECK ALL FASTENERS BEFORE INITIAL USE, AND PERIODICALLY IN THE FUTURE TO ENSURE PROPER FUNCTION AND SAFETY.**

DRILLING:

Most Westin products do not require drilling for installation. If drilling is defined as required, use caution when drilling a vehicle. **FAILURE TO REVIEW AN AREA TO BE DRILLED MAY RESULT IN PERSONAL INJURY AND/OR INJURY TO OTHERS AS WELL AS VEHICLE DAMAGE.**

EYE PROTECTION:

ALWAYS WEAR SAFETY GLASSES OR GOGGLES DURING THE INSTALLATION PROCESS TO AVOID PERSONAL INJURY.

MAXIMUM TOWING/CARRYING CAPACITY:

The Westin Receiver Hitches will have a visible tow rating label affixed directly on the product. User should never exceed the vehicle manufacturers maximum tow and weight rating regardless of the capacity of the hitch. **FAILURE TO FOLLOW THESE GUIDELINES WILL VOID THE WESTIN WARRANTY AND MAY RESULT IN PERSONAL INJURY AND/OR INJURY TO OTHERS AS WELL AS VEHICLE DAMAGE.**



Westin Automotive Products, Inc.
320 W. Covina Blvd
San Dimas, Ca. 91773

Thank you for choosing Westin products
for additional installation assistance please call
Customer Service (800) 793-7846
www.westinautomotive.com