



AUTOMOTIVE PRODUCTS,

INSTALLATION INSTRUCTIONS

OFF-ROAD LIGHT BAR

APPLICATION:

2009-2017 Dodge Ram 1500 (Excl. Rebel Model)

PART NUMBER:

37-02580, 37-02585

ITEM	QUANTITY	DESCRIPTION	TOOLS NEEDED
1	1	LIGHT BAR ASSEMBLY	18MM SOCKET
2	2	MOUNTING BRACKETS (FOR VEHICLES W/O TOW HOOKS)	18MM WRENCH
3	4	M12 HEX HEAD BOLT	RATCHET
4	8	M12 FLAT WASHER	TORQUE WRENCH
5	4	M12 SPRING LOCK WASHER	
6	4	M12 HEX NUT	

ANTI-SEIZE LUBRICANT MUST BE USED ON ALL STAINLESS STEEL FASTENERS TO PREVENT THREAD DAMAGE AND GALLING

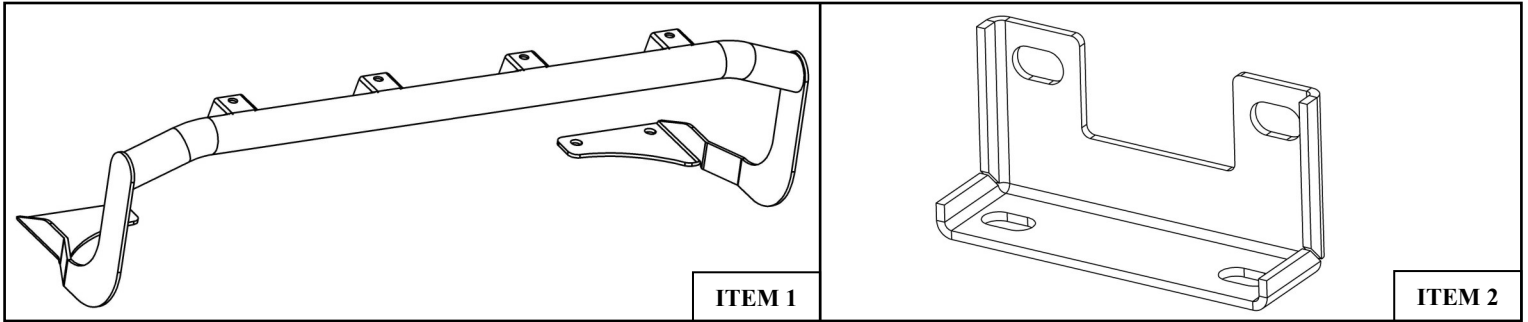

PROCEDURE

1. Remove contents from box, verify if all parts listed are present and free from damage. Carefully read and understand all instructions before attempting installation.

Failure to identify damage before installation could lead to a rejection of any claim.

If the vehicle is equipped with tow hooks, remove the two front bolts from each tow hook and follow steps 2-3 and 7:

2. Slide light bar assembly through the front bumper under the tow hooks. Refer to **Figure 1**.
3. Secure the light bar with the factory hardware. Refer to **Figure 1**.

If the vehicle is not equipped with tow hooks, remove the plastic bumper plug from the front bumper and follow steps 4-7:

4. Remove the two 18MM hex nuts located at the bottom of each bumper mounting bracket at the vehicle frame.
5. Install one tow hook replacement bracket at each bumper bracket and secure with the factory hardware. Do not fully tighten at this time. Refer to **Figure 2 and 3**.
6. Slide the light bar assembly through the front bumper and under the tow hook replacement brackets. Secure the light bar to the brackets with the supplied M12 hardware (Items 3-6). Refer to **Figure 2 and 3**.
7. Tighten all M12 hardware to approx. 50-55 lbs-ft.



Westin Automotive Products, Inc.
320 W. Covina Blvd
San Dimas, Ca. 91773

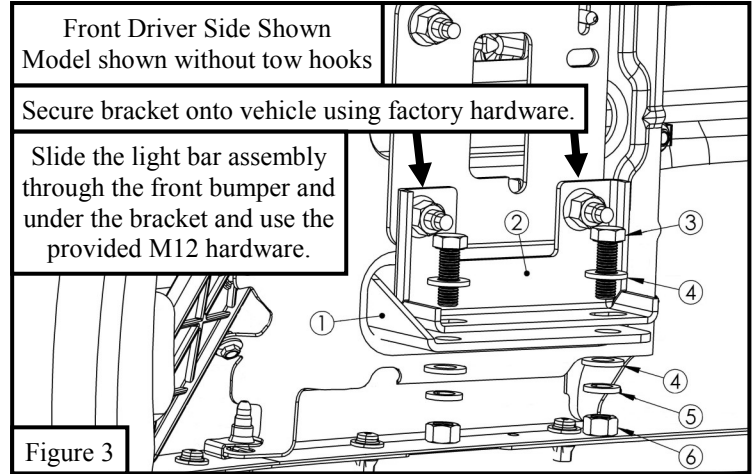
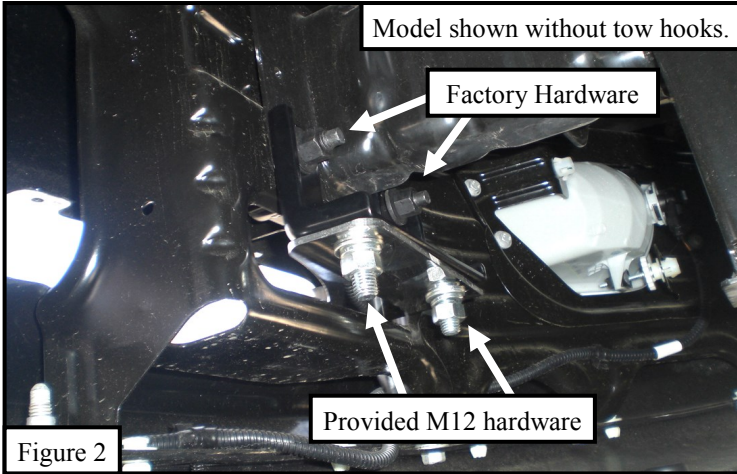
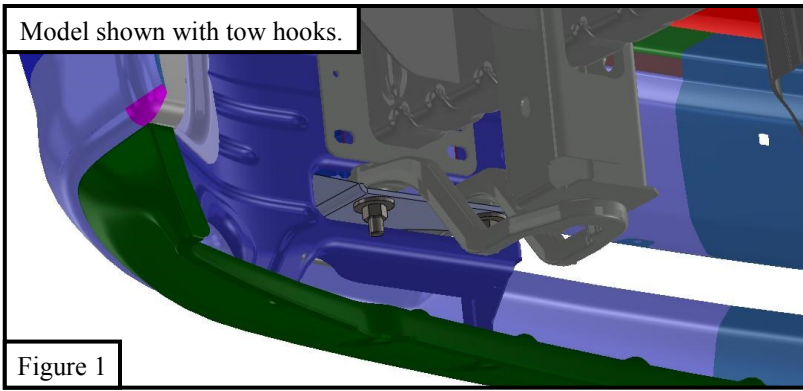

CARE INSTRUCTIONS

- REGULAR WAXING IS RECOMMENDED. DO NOT USE ANY TYPE OF POLISH OR WAX THAT MAY CONTAIN ABRASIVES.
- STAINLESS STEEL PRODUCTS CAN BE CLEANED WITH MILD SOAP AND WATER. STAINLESS STEEL POLISH SHOULD BE USED TO POLISH SMALL SCRATCHES.
- GLOSS BLACK FINISHES SHOULD BE CLEANED WITH MILD SOAP AND WATER.



Westin Automotive Products, Inc.
320 W. Covina Blvd
San Dimas, Ca. 91773

Thank you for choosing Westin products
for additional installation assistance please call
Customer Service (800) 793-7846
www.westinautomotive.com

Westin

SIGNATURE OF QUALITY

AUTOMOTIVE PRODUCTS, INC.



WARNING



Failure to follow these instructions could lead to death, personal injury, and / or property damage.

FASTENERS:

All Westin supplied fasteners must be utilized and installed in accordance with the installation instructions and apply torque to the specifications as defined. **DOUBLE CHECK ALL FASTENERS BEFORE INITIAL USE, AND PERIODICALLY IN THE FUTURE TO ENSURE PROPER FUNCTION AND SAFETY.**

DRILLING:

Most Westin products do not require drilling for installation. If drilling is defined as required, use caution when drilling a vehicle. **FAILURE TO REVIEW AN AREA TO BE DRILLED MAY RESULT IN PERSONAL INJURY AND/OR INJURY TO OTHERS AS WELL AS VEHICLE DAMAGE.**

EYE PROTECTION:

ALWAYS WEAR SAFETY GLASSES OR GOGGLES DURING THE INSTALLATION PROCESS TO AVOID PERSONAL INJURY.

MAXIMUM TOWING/CARRYING CAPACITY:

The Westin Receiver Hitches will have a visible tow rating label affixed directly on the product. User should never exceed the vehicle manufacturers maximum tow and weight rating regardless of the capacity of the hitch. **FAILURE TO FOLLOW THESE GUIDELINES WILL VOID THE WESTIN WARRANTY AND MAY RESULT IN PERSONAL INJURY AND/OR INJURY TO OTHERS AS WELL AS VEHICLE DAMAGE.**

Westin
SIGNATURE OF QUALITY

Westin Automotive Products, Inc.
320 W. Covina Blvd
San Dimas, Ca. 91773