

INSTALLATION INSTRUCTIONS



OUTLAW DROP STEPS

APPLICATION:

1999-2013 Chevrolet Silverado/GMC Sierra 1500 Ext Cab;
2001- 2019 Chevrolet Silverado/GMC Sierra 2500/3500 Extended/
Double Cab (Body Mount)

PART NUMBERS:

20-11685, 20-11955

CONTENT			
ITEM	QUANTITY	DESCRIPTION	TOOLS NEEDED
1	1	DRIVER SIDE OUTLAW DROP NERF STEP BAR	14MM SOCKET
2	1	PASSENGER SIDE OUTLAW DROP NERF STEP BAR	14MM WRENCH
3	1	DRIVER SIDE FRONT MOUNT BRACKET	15MM SOCKET
4	1	PASSENGER SIDE FRONT MOUNT BRACKET	15MM WRENCH
5	1	DRIVER SIDE CENTER MOUNT BRACKET	RATCHET
6	1	PASSENGER SIDE CENTER MOUNT BRACKET	TORQUE WRENCH
7	1	DRIVER SIDE REAR MOUNT BRACKET	
8	1	PASSENGER SIDE REAR MOUNT BRACKET	
9	1	DRIVER SIDE CENTER SUPPORT STRAP	
10	1	PASSENGER SIDE CENTER SUPPORT STRAP	
11	2	M10 U BOLT	
12	12	M10 SERRATED FLANGE HEX HEAD BOLT	
13	12	M10 SERRATED FLANGE NUT	
14	6	M10 HEX NUT	
15	8	M10 FLAT WASHER	
16	6	M10 SPLIT LOCK WASHER	
17	2	M10 HEX HEAD BOLT	

ANTI-SEIZE LUBRICANT MUST BE USED ON ALL STAINLESS STEEL FASTENERS TO PREVENT THREAD DAMAGE AND GALLING

Extended Cab, Double Cab is Similar

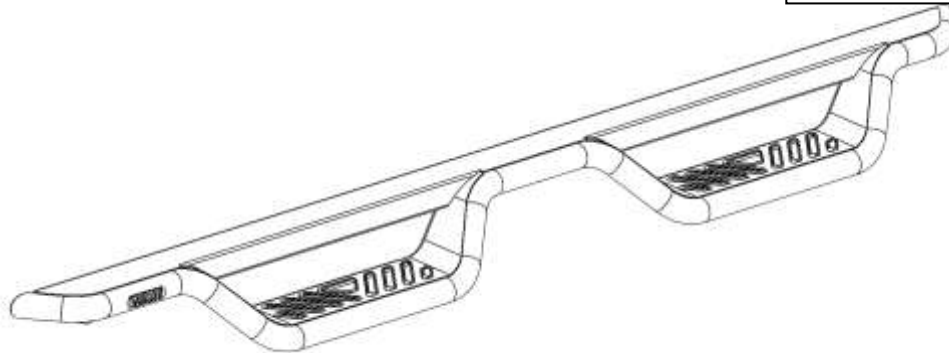

ITEM 1

Driver Side Shown



Westin Automotive Products, Inc.
320 W. Covina Blvd
San Dimas, Ca. 91773

Thank you for choosing Westin products
for additional installation assistance please call
Customer Service (800) 793-7846
www.westinautomotive.com

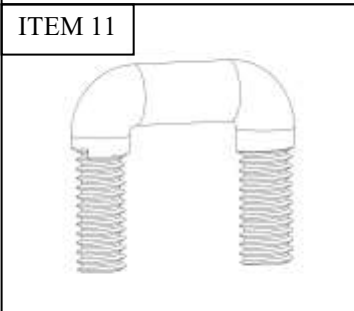
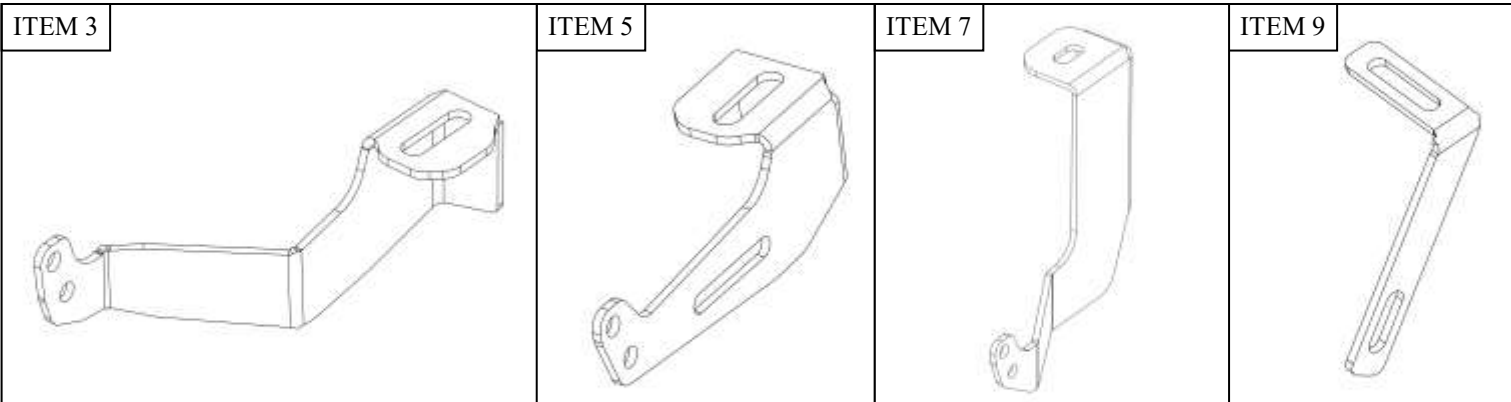

PROCEDURE

1. Remove contents from box, verify if all parts listed are present and free from damage. Carefully read and understand all instructions before attempting installation. **Failure to identify damage before installation could lead to a rejection of any claim.**
2. Starting on the front driver side of the vehicle, remove the factory bolt from the puck mount on the frame. Locate Driver Side Mount Bracket (Item 3) and install loosely with previously removed factory bolt. See **Figures 1 and 2** for reference.

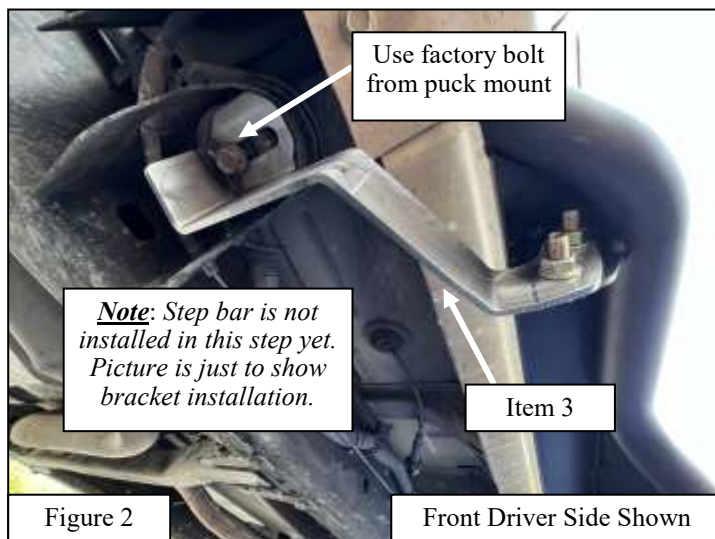
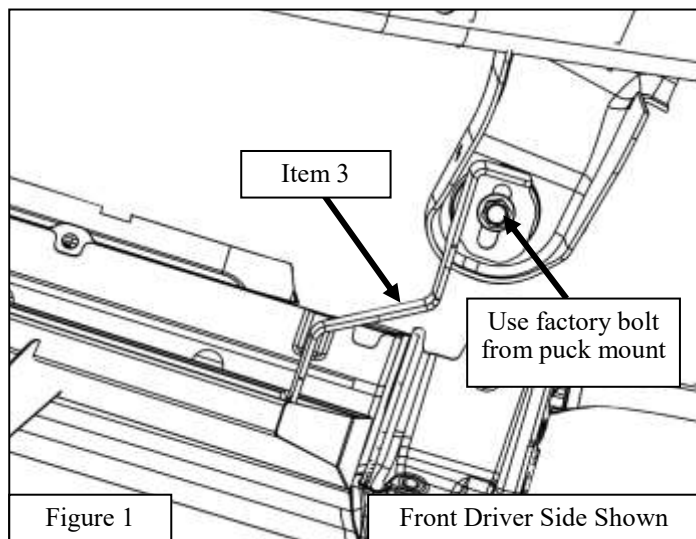

3. Move to the center mount position and insert the provided M10 U Bolt into the opening shown in **Figure 3**.
4. On the center mount position, locate Driver Side Center Mount Bracket (Item 5) and loosely install it with the factory bolt. See **Figure 4** for reference.
5. Locate Driver Support Strap (Item 9) and loosely mount it to the Driver Side Center Mount Bracket (Item 5) and previously mounted U-Bolt using the provided M10 hardware (Items 14-17). See **Figures 4 and 5** for reference.

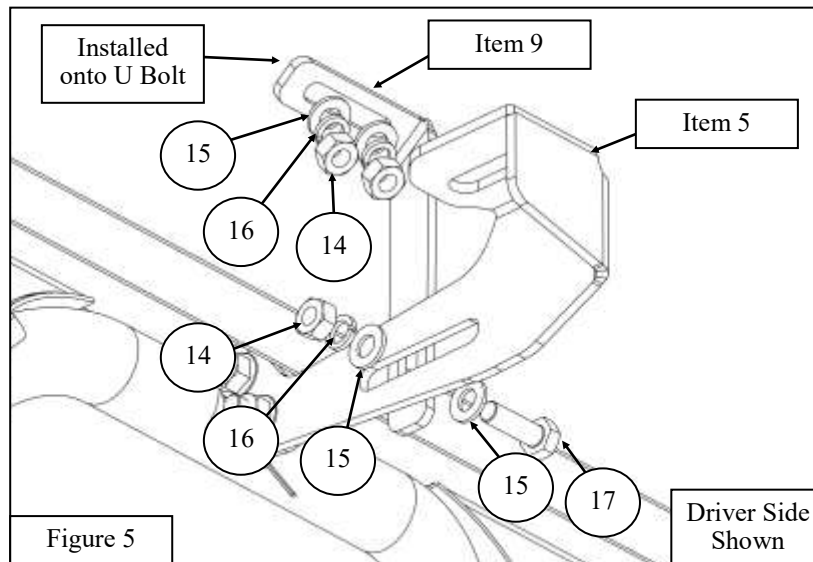
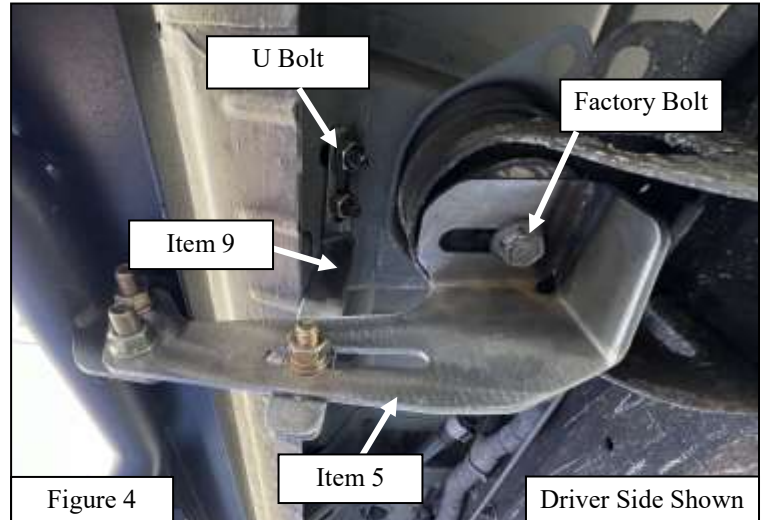
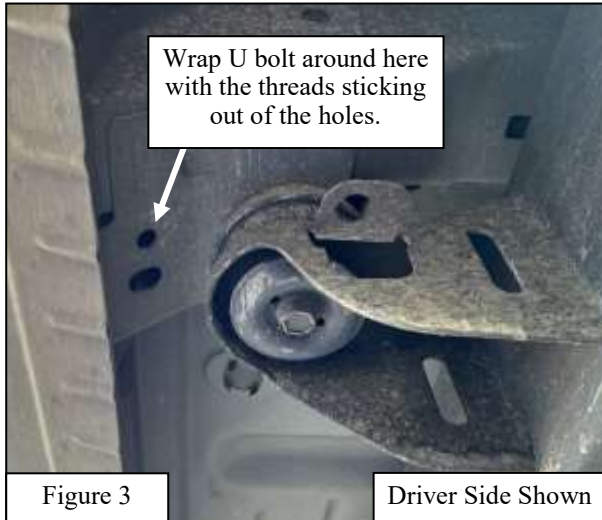

6. Move on to the rear body puck mount. Locate Driver Side Rear Mount Bracket (Item 7) and loosely install it with the factory bolt. See **Figure 6** for reference.

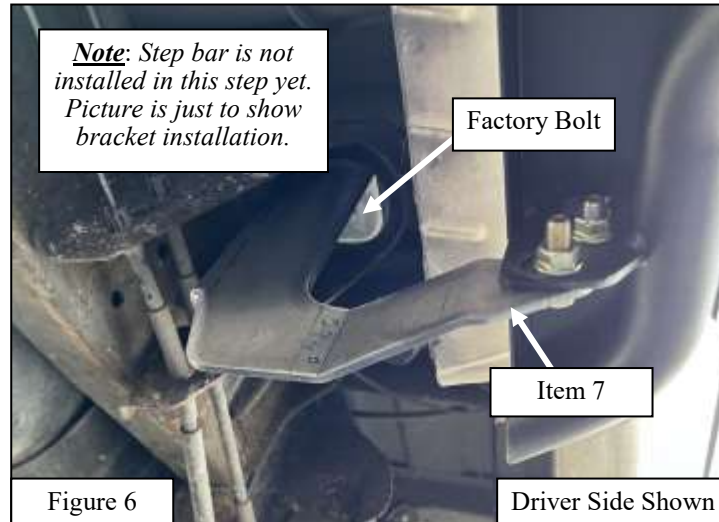

7. Loosely install step bars respectively to either side using the provided M10 hardware (Items 12 and 13). See **Figures 7** for reference.
8. Repeat **Steps 2 through 7** for passenger side brackets and step bar.

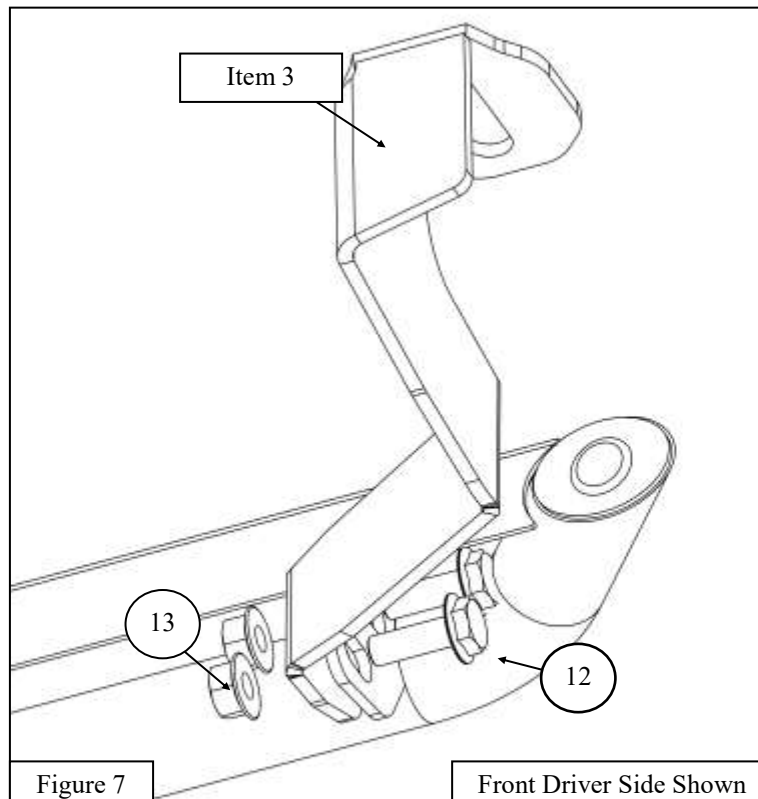

9. The final orientation of the mounting brackets and the Outlaw Drop Steps should be as shown in **Figures 10 and 11**.
10. Align and adjust the step bars as needed. Tighten and torque all M10 hardware to 30-32 ft-lbs.

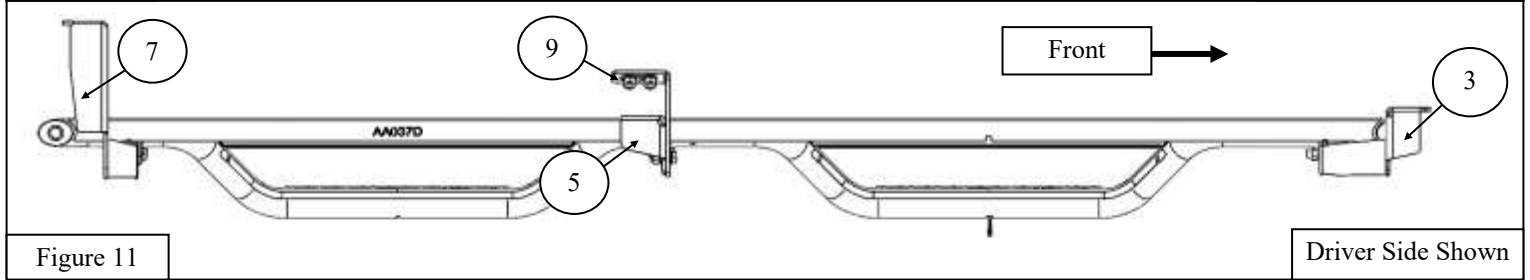
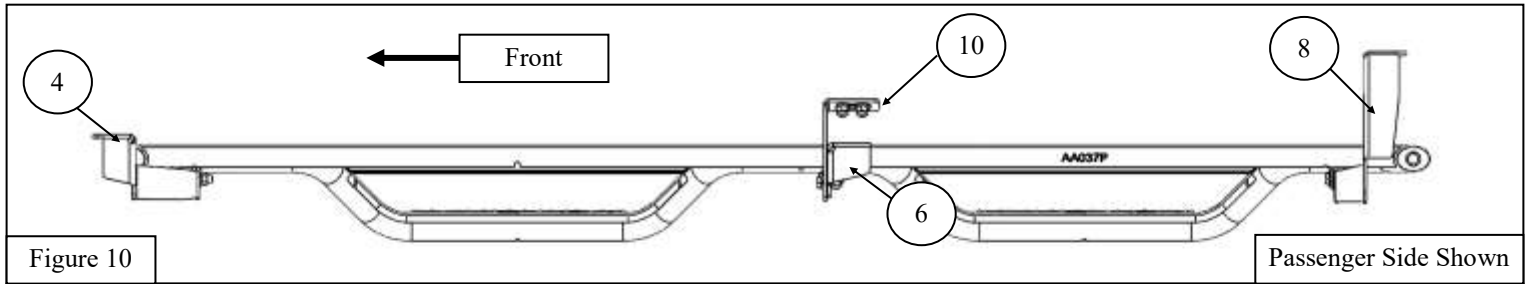

INSTALLATION COMPLETE



- CARE INSTRUCTIONS**
- REGULAR WAXING IS RECOMMENDED. DO NOT USE ANY TYPE OF POLISH OR WAX THAT MAY CONTAIN ABRASIVES.
 - STAINLESS STEEL PRODUCTS CAN BE CLEANED WITH MILD SOAP AND WATER. STAINLESS STEEL POLISH SHOULD BE USED TO POLISH SMALL SCRATCHES.
 - GLOSS BLACK FINISHES SHOULD BE CLEANED WITH MILD SOAP AND WATER.

WESTIN Westin Automotive Products, Inc.
320 W. Covina Blvd
San Dimas, Ca. 91773

Thank you for choosing Westin products
for additional installation assistance please call
Customer Service (800) 793-7846
www.westinautomotive.com
DATE: 3/20/2023



WARNING



Failure to follow these instructions could lead to death, personal injury, and / or property damage.

Failure to follow these instructions could lead to death, personal injury, and / or property damage.

FASTENERS:

All Westin supplied fasteners must be utilized and installed in accordance with the installation instructions and apply torque to the specifications as defined. **DOUBLE CHECK ALL FASTENERS BEFORE INITIAL USE, AND PERIODICALLY IN THE FUTURE TO ENSURE PROPER FUNCTION AND SAFETY.**

DRILLING:

Most Westin products do not require drilling for installation. If drilling is defined as required, use caution when drilling a vehicle. **FAILURE TO REVIEW AN AREA TO BE DRILLED MAY RESULT IN PERSONAL INJURY AND/OR INJURY TO OTHERS AS WELL AS VEHICLE DAMAGE.**

EYE PROTECTION:

ALWAYS WEAR SAFETY GLASSES OR GOGGLES DURING THE INSTALLATION PROCESS TO AVOID PERSONAL INJURY.

MAXIMUM TOWING/CARRYING CAPACITY: (if applicable)

The Westin Receiver Hitches will have a visible tow rating label affixed directly on the product. User should never exceed the vehicle manufacturers maximum tow and weight rating regardless of the capacity of the hitch. **FAILURE TO FOLLOW THESE GUIDELINES WILL VOID THE WESTIN WARRANTY AND MAY RESULT IN PERSONAL INJURY AND/OR INJURY TO OTHERS AS WELL AS VEHICLE DAMAGE.**

FOR CALIFORNIA RESIDENTS ONLY-PROP 65 WARNING:

Some products may contain chemicals such as DEHP, which can cause cancer, birth defects or other reproductive harm. For more info go to www.p65warnings.ca.gov



Westin Automotive Products, Inc.
320 W. Covina Blvd
San Dimas, Ca. 91773