



INSTALLATION INSTRUCTIONS

ACTIVE CRUISE CONTROL RELOCATION KIT

APPLICATION:

F-150 2015-2020; Ford F-150 Raptor 2017-2020 (Accessory for Pro-Mod & Outlaw Front Bumper)

PART NUMBER:

58-40005

CONTENT			
ITEM	QUANTITY	DESCRIPTION	TOOLS NEEDED
1	1	BRACKET A	10MM SOCKET
2	1	BRACKET B	15MM SOCKET
3	6	M6 FLAT WASHER	ALLEN
4	3	M6 NYLOCK HEX NUT	RATCHET
5	3	M6 BUTTON HEAD BOLT	TORQUE WRENCH
6	2	M10 BUTTON HEAD BOLT	
7	2	M10 SERRATED FLANGE NUT	
8	2	M10 FLAT WASHER	

ANTI-SEIZE LUBRICANT MUST BE USED ON ALL STAINLESS STEEL FASTENERS TO PREVENT THREAD DAMAGE AND GALLING

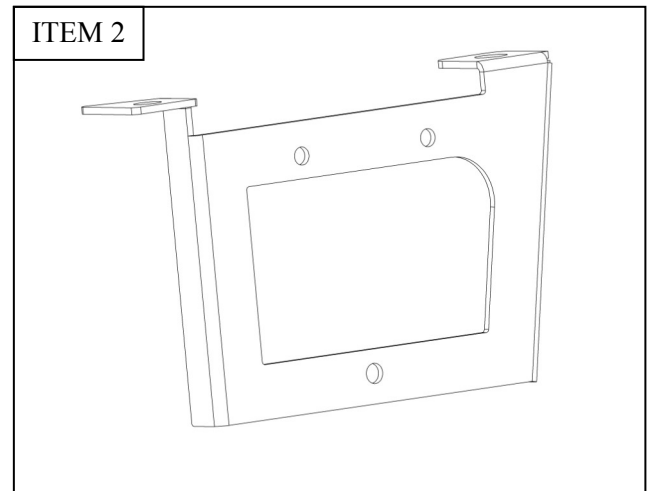
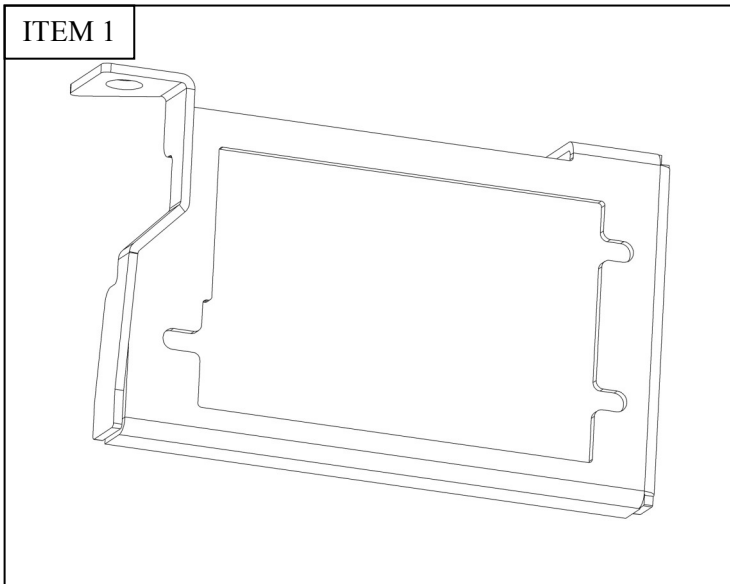

PROCEDURE

1. Remove contents from box, verify if all parts listed are present and free from damage.
Carefully read and understand all instructions before attempting installation.
Failure to identify damage before installation could lead to a rejection of any claim.

2. Remove the factory cruise control brackets and hardware from the front bumper on the driver side. *Note: There are 2 different styles of cruise control modules that are removed the same way. Both types of brackets are supplied. See Figure 1*

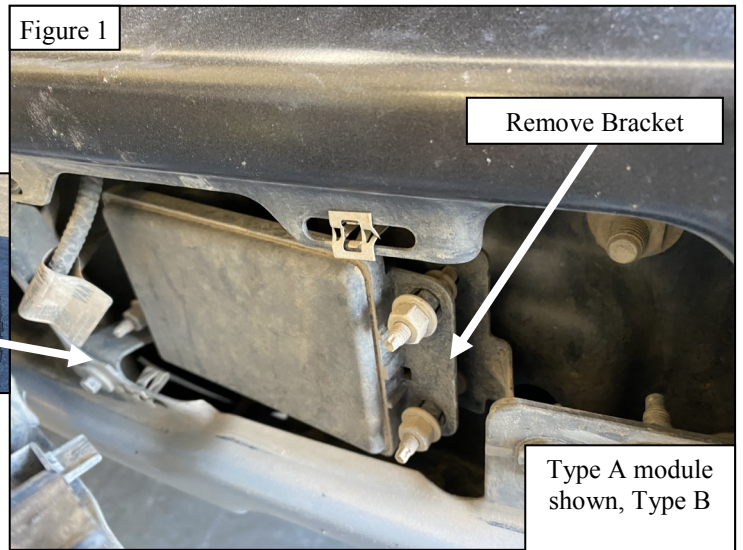

3. For F-150 model (Non Raptor), starting on either side, remove the headlight trim panel by removing two bolts on the side near the front tire and a plastic clip on the top near the engine. Start removing the headlight trim from the top first and then the bottom. Then work your way towards removing the middle portion. See **Figures 1 - 3**. Repeat step for opposite side.

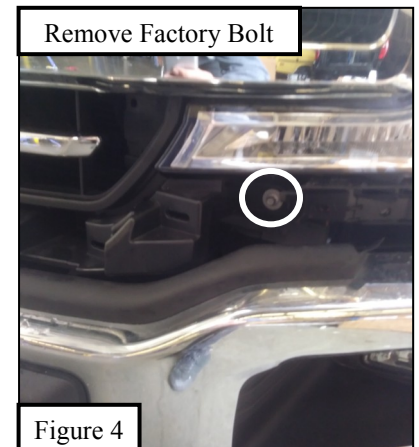
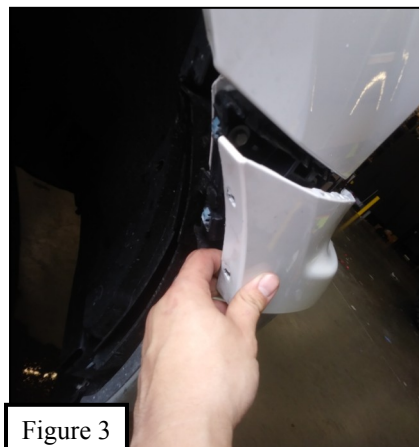

3. Locate plastic push pins on the radiator cover. Remove the plastic push pins in order to remove the radiator cover. See **Figures 4 & 5**. **Note:** Un-plug any electrical connectors that connect to the grille.
4. Remove (4) bolts that attach the grille to the vehicle. Then lift the grille up and off the truck. See **Figures 5 & 6**.
5. Once the grille is off, remove the (4) push pins that hold the top portion of the grille can be pulled off. See **Figure 6**.

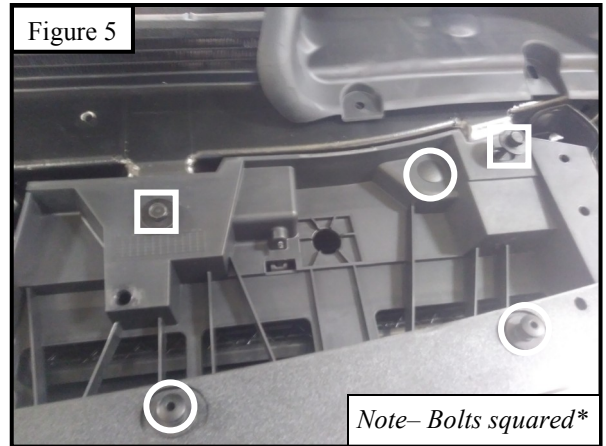

3. Using supplied M6 hardware, assemble the module to the supplied bracket. Use either Bracket A or B accordingly. See **Figure 3-4**

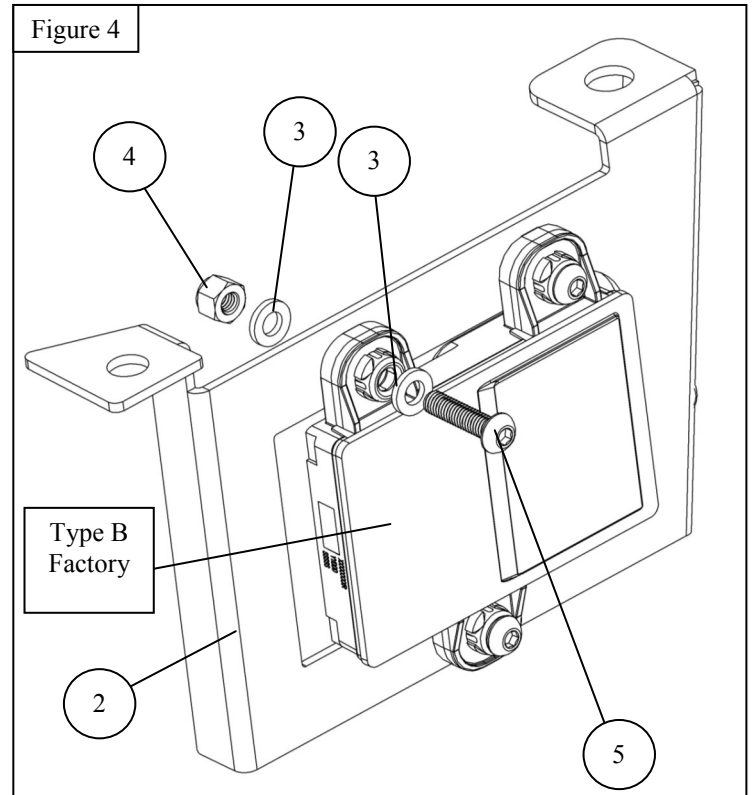
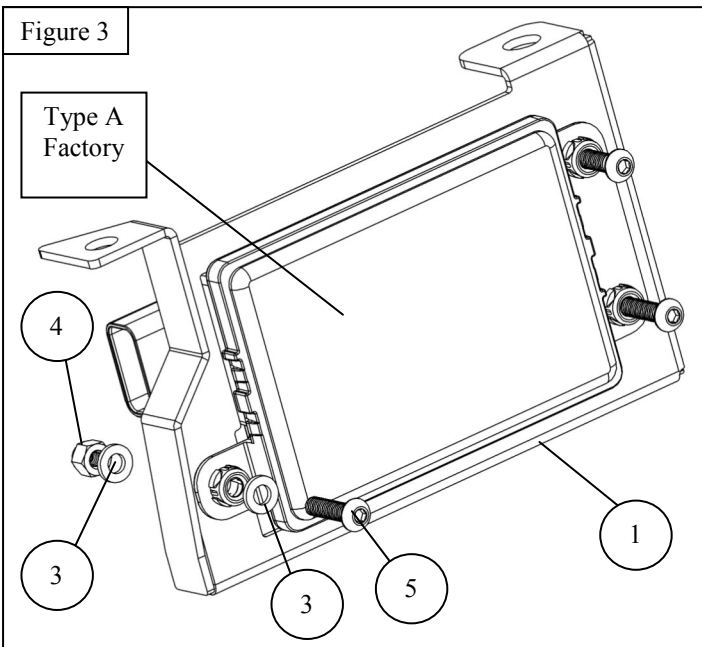

- Using supplied M10 hardware, mount the bracket to the inside of the grille support (driver side). See Figure 5, 6.
- Re-route the wiring as needed and plug in to the cruise control module.
- Torque all hardware as specified: M6 to 5-7 ft-lbs, M10 to 35 ft-lbs

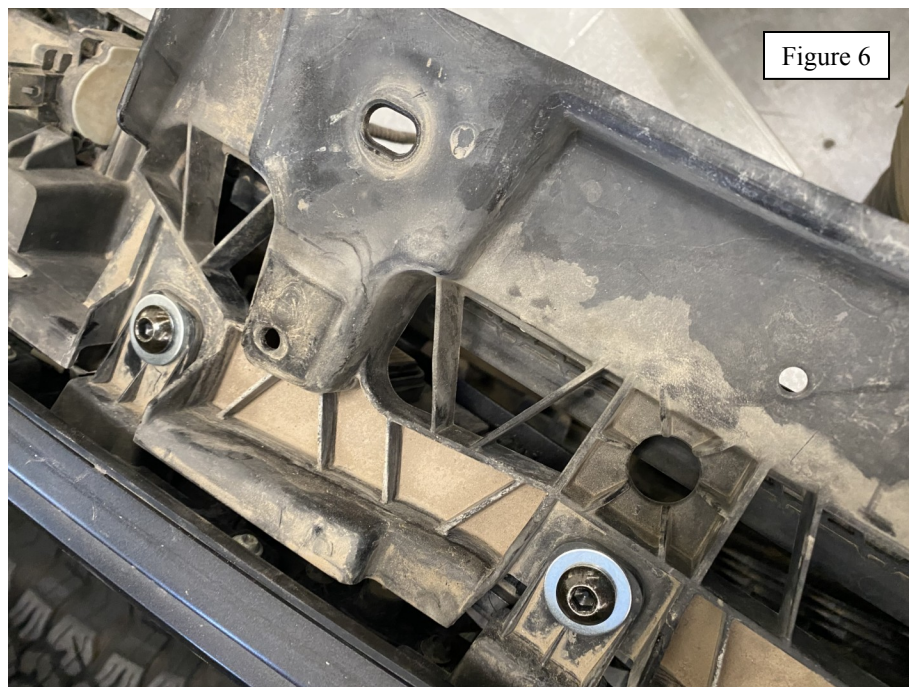
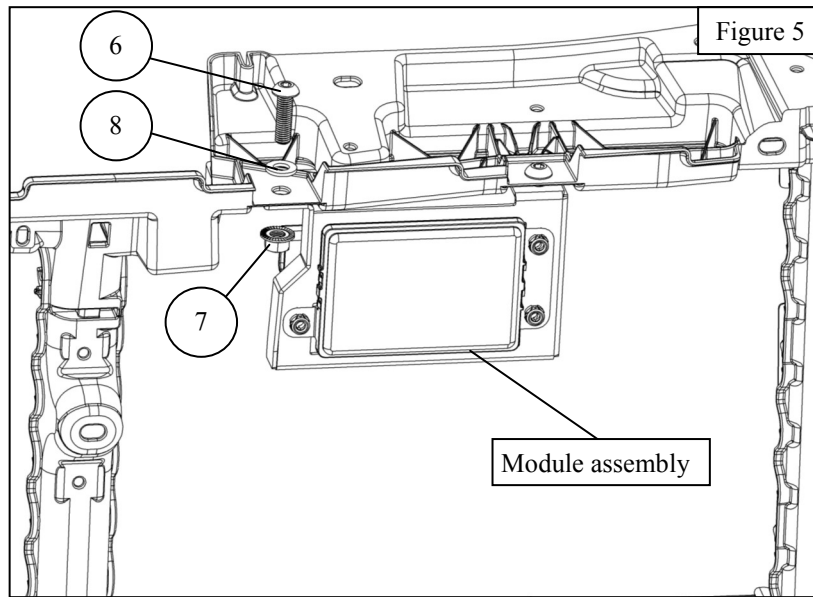

CARE INSTRUCTIONS

- REGULAR WAXING IS RECOMMENDED. DO NOT USE ANY TYPE OF POLISH OR WAX THAT MAY CONTAIN ABRASIVES.
- STAINLESS STEEL PRODUCTS CAN BE CLEANED WITH MILD SOAP AND WATER. STAINLESS STEEL POLISH SHOULD BE USED TO POLISH SMALL SCRATCHES.
- GLOSS BLACK FINISHES SHOULD BE CLEANED WITH MILD SOAP AND WATER.

WESTIN Westin Automotive Products, Inc.
320 W. Covina Blvd
San Dimas, Ca. 91773

Thank you for choosing Westin products
for additional installation assistance please call
Customer Service (800) 793-7846

INSTALLATION COMPLETED





WARNING



Failure to follow these instructions could lead to death, personal injury, and / or property damage.

Failure to follow these instructions could lead to death, personal injury, and / or property damage.

FASTENERS:

All Westin supplied fasteners must be utilized and installed in accordance with the installation instructions and apply torque to the specifications as defined. **DOUBLE CHECK ALL FASTENERS BEFORE INITIAL USE, AND PERIODICALLY IN THE FUTURE TO ENSURE PROPER FUNCTION AND SAFETY.**

DRILLING:

Most Westin products do not require drilling for installation. If drilling is defined as required, use caution when drilling a vehicle. **FAILURE TO REVIEW AN AREA TO BE DRILLED MAY RESULT IN PERSONAL INJURY AND/OR INJURY TO OTHERS AS WELL AS VEHICLE DAMAGE.**

EYE PROTECTION:

ALWAYS WEAR SAFETY GLASSES OR GOGGLES DURING THE INSTALLATION PROCESS TO AVOID PERSONAL INJURY.

MAXIMUM TOWING/CARRYING CAPACITY: (if applicable)

The Westin Receiver Hitches will have a visible tow rating label affixed directly on the product. User should never exceed the vehicle manufacturers maximum tow and weight rating regardless of the capacity of the hitch. **FAILURE TO FOLLOW THESE GUIDELINES WILL VOID THE WESTIN WARRANTY AND MAY RESULT IN PERSONAL INJURY AND/OR INJURY TO OTHERS AS WELL AS VEHICLE DAMAGE.**

FOR CALIFORNIA RESIDENTS ONLY-PROP 65 WARNING:

Some products may contain chemicals such as DEHP, which can cause cancer, birth defects or other reproductive harm. For more info go to www.p65warnings.ca.gov



Westin Automotive Products, Inc.
320 W. Covina Blvd
San Dimas, Ca. 91773

Thank you for choosing Westin products
for additional installation assistance please call
Customer Service (800) 793-7846
www.westinautomotive.com