

INSTALLATION INSTRUCTIONS

PRO-MOD FRONT BUMPER



APPLICATION:
2013-2018 Ram 1500; 2019 Ram 1500 Classic
PART NUMBER:
58-41025

CONTENT			
ITEM	QUANTITY	DESCRIPTION	TOOLS NEEDED
1	1	DRIVER SIDE POD ASSEMBLY	10MM SOCKET
2	1	PASSENGER SIDE POD ASSEMBLY	10MM WRENCH
3	2	MESH COVER PLATE	13MM SOCKET
4	1	CENTER SECTION	13MM WRENCH
5	1	VALANCE SKID PLATE	16MM SOCKET
6	1	DRIVER MOUNTING BRACKET	16MM WRENCH
7	1	PASSENGER MOUNTING BRACKET	18MM SOCKET
8	1	M10 NUT PLATE	19MM WRENCH
9	6	SENSOR TAB	RATCHET
10	1	M10 BOLT PLATE	TORQUE WRENCH
11	1	DRIVER SIDE STRAP	
12	1	PASSENGER SIDE STRAP	
13	1	DRIVER VALANCE MOUNT BRACKET	
14	1	PASSENGER VALANCE MOUNT BRACKET	
15	1	DRIVER FILLER TRIANGLE	
16	1	PASSENGER FILLER TRIANGLE	
17	2	LED BRACKET	
18	6	HOLE PLUG	
19	10	M12 HEX HEAD BOLT (YELLOW ZINC)	
20	10	M12 HEX NUT (YELLOW ZINC)	
21	20	M12 FLAT WASHER (YELLOW ZINC)	
22	20	M12 SPLIT LOCK WASHER (YELLOW ZINC)	
23	6	M6 CARRIAGE BOLT (YELLOW ZINC)	
24	6	M6 SPLIT LOCK WASHER (YELLOW ZINC)	
25	6	M6 HEX NUT (YELLOW ZINC)	
26	6	M6 FLAT WASHER (YELLOW ZINC)	
27	6	M10 HEX HEAD BOLT (YELLOW ZINC)	
28	6	M10 SPLIT LOCK WASHER (YELLOW ZINC)	

ANTI-SEIZE LUBRICANT MUST BE USED ON ALL STAINLESS STEEL FASTENERS TO PREVENT THREAD DAMAGE AND GALLING

WESTIN Westin Automotive Products, Inc.
320 W. Covina Blvd
San Dimas, Ca. 91773

Thank you for choosing Westin products
for additional installation assistance please call
Customer Service (800) 793-7846

ITEM	QUANTITY	DESCRIPTION	TOOLS NEEDED
29	12	M10 FLAT WASHER (YELLOW ZINC)	
30	6	M10 HEX NUT (YELLOW ZINC)	
31	4	M8 U-CLIPS (YELLOW ZINC)	
32	12	M8 BUTTON HEAD BOLT (BLACK ZINC)	
33	26	M8 FLAT WASHER (BLACK ZINC)	
34	14	M8 SPLIT LOCK WASHER (BLACK ZINC)	
35	10	M8 HEX NUT (BLACK ZINC)	
36	2	M8 HEX HEAD BOLT (BLACK ZINC)	
37	12	M6 FLAT WASHER (BLACK ZINC)	
38	12	M6 SPLIT LOCK WASHER (BLACK ZINC)	
39	12	M6 BUTTON HEAD BOLT (BLACK ZINC)	
40	12	M6 SERRATED FLANGE NUT (BLACK ZINC)	
41	2	LONG M10 HEX HEAD BOLT (BLACK ZINC)	
42	3	M10 HEX NUT (BLACK ZINC)	
43	6	M10 FLAT WASHER (BLACK ZINC)	
44	4	M10 SPLIT LOCK WASHER (BLACK ZINC)	
45	1	SHORT M10 HEX HEAD BOLT (BLACK ZINC)	

ANTI-SEIZE LUBRICANT MUST BE USED ON ALL STAINLESS STEEL FASTENERS TO PREVENT THREAD DAMAGE AND GALLING

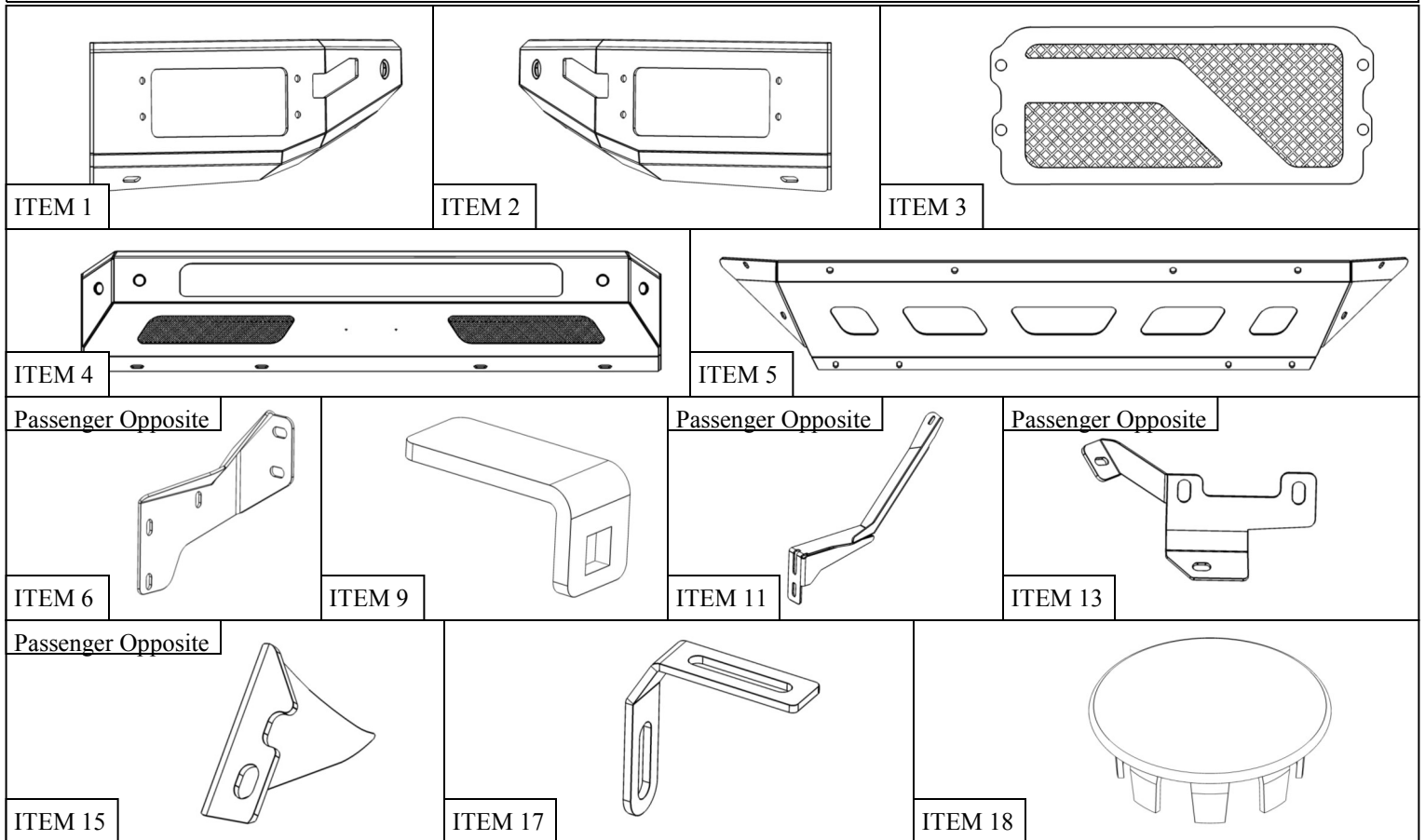

WESTIN Westin Automotive Products, Inc.
320 W. Covina Blvd
San Dimas, Ca. 91773

Thank you for choosing Westin products
for additional installation assistance please call
Customer Service (800) 793-7846

PROCEDURE

1. Remove contents from box, verify if all parts listed are present and free from damage. Carefully read and understand all instructions before attempting installation. **Failure to identify damage before installation could lead to a rejection of any claim.**
2. Disconnect any electrical connectors that are attached to front bumper. Including parking sensor harness, fog lights, etc.
3. Remove tow hooks if equipped.
4. Locate original nuts fastening bumper to frame and remove using 18mm wrench. See **Figures 1 & 2.**
5. Carefully remove bumper assembly. See **Figure 3.**

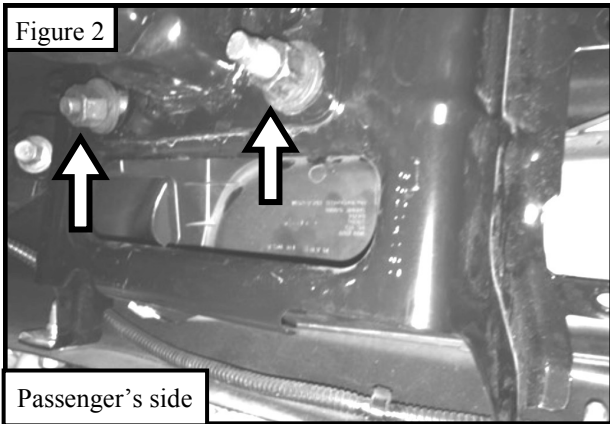
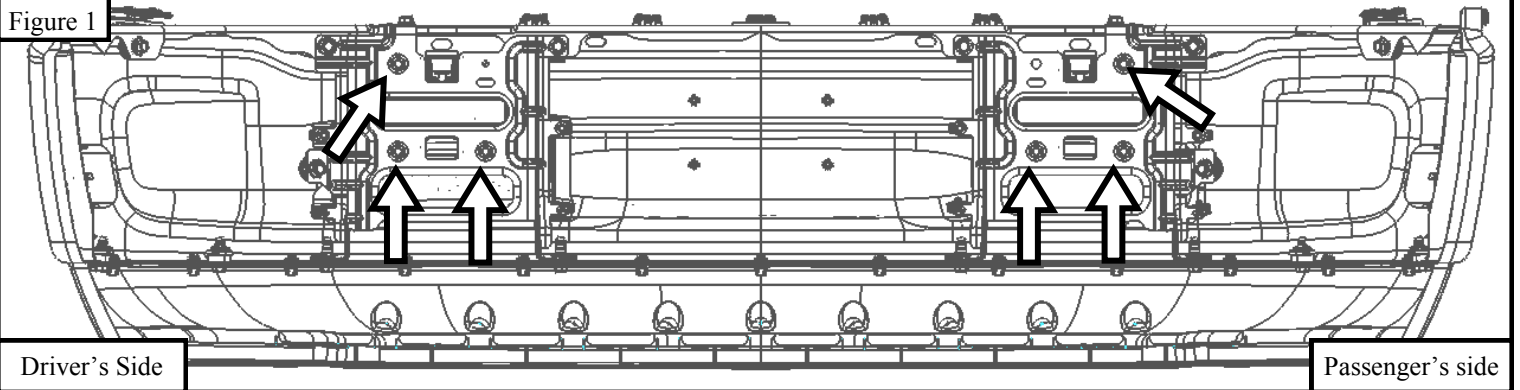

5. Remove filler panel between bumper and grille. Start by removing screws around fender area fastening the filler panel to the body of the truck. Use a 10mm socket. See **Figure 4 –5.**

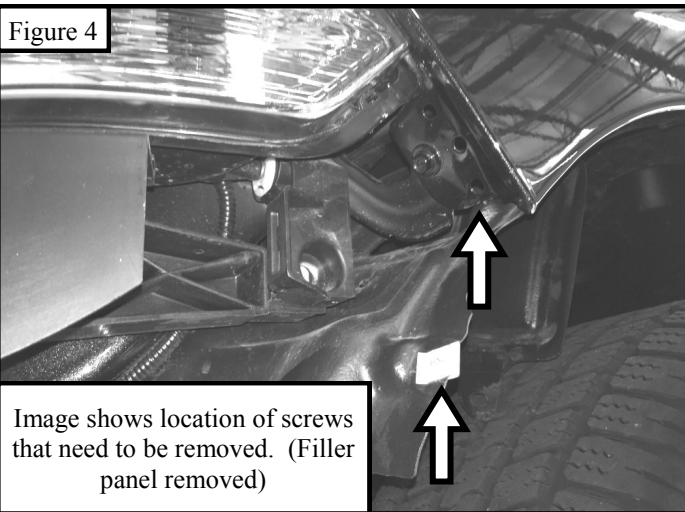

6. After all screws holding filler panel have been removed, carefully pull starting from either side and un-clip tabs holding filler panel to the truck.

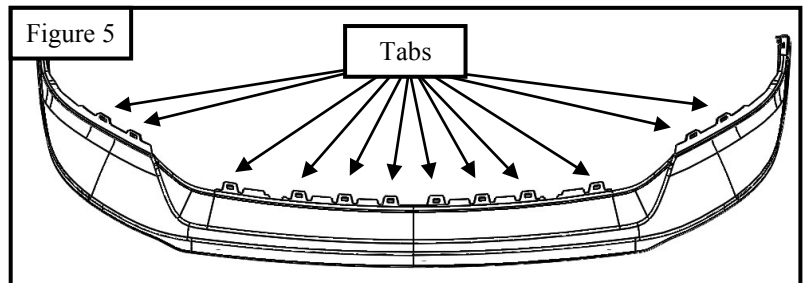
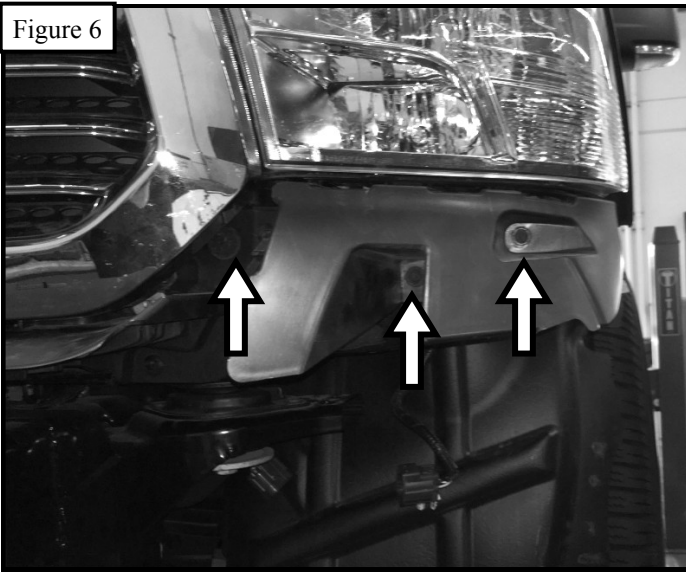
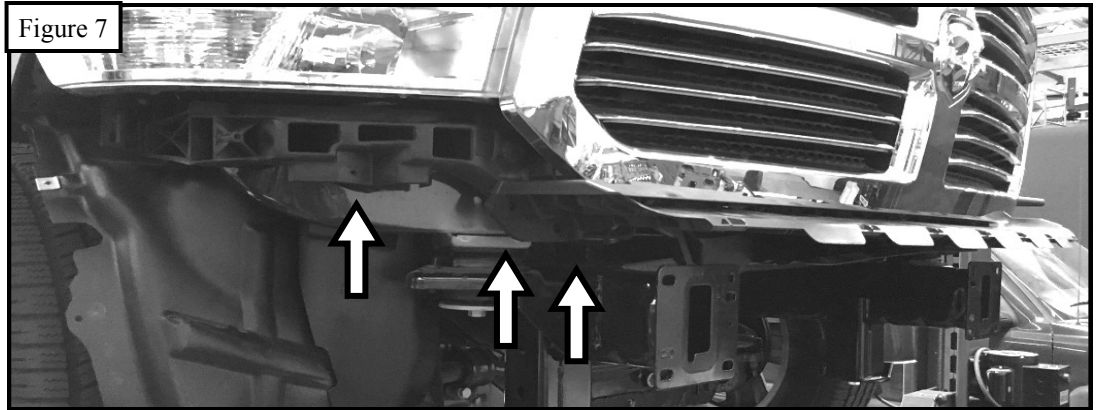

Figure 6



7. Remove plastic pieces behind filler panel using 10mm socket. Once all screws have been removed, carefully pull plastic pieces and un-clip tabs around grille area. See Figures 6-7.

Figure 7



- 8. Use the supplied M10 Hardware to attach each Side Pod Assembly (1,2) to the Center Section (4). See Figure 8.
- 9. Use the supplied M6 Hardware to attach the LED Brackets (17) to the center section. See Figure 9. *Note: If installing an LED Light Bar (sold separately), install it at this time.*

Driver Side Shown

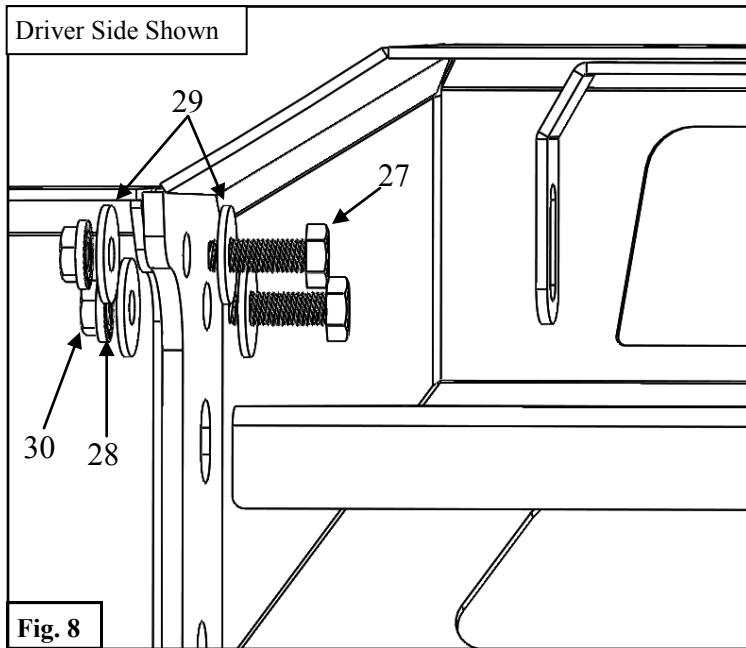

Fig. 8

Driver Side Shown

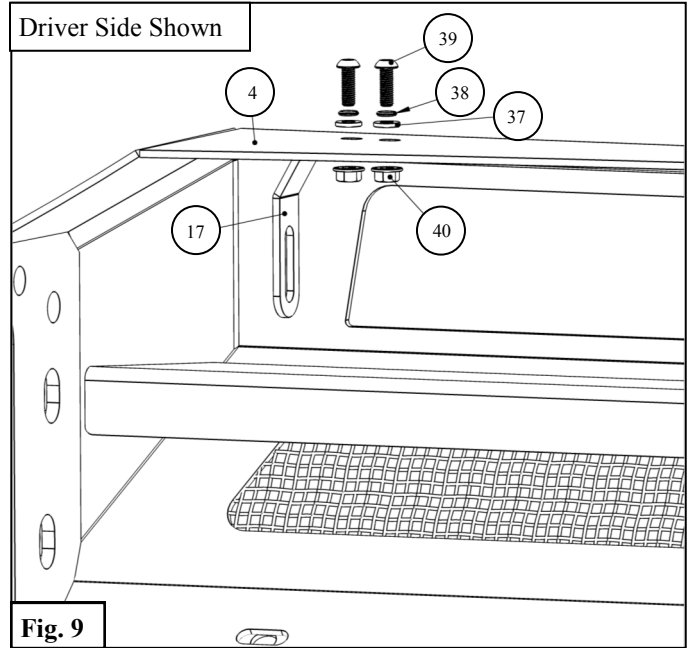

Fig. 9



Westin Automotive Products, Inc.
320 W. Covina Blvd
San Dimas, Ca. 91773

Thank you for choosing Westin products
for additional installation assistance please call
Customer Service (800) 793-7846

www.westinautomotive.com

DATE: 04/15/19

10. Loosely install the bumper assembly to the Mounting Brackets (6,7) using the supplied M12 Hardware. See **Figures 10 & 11.**

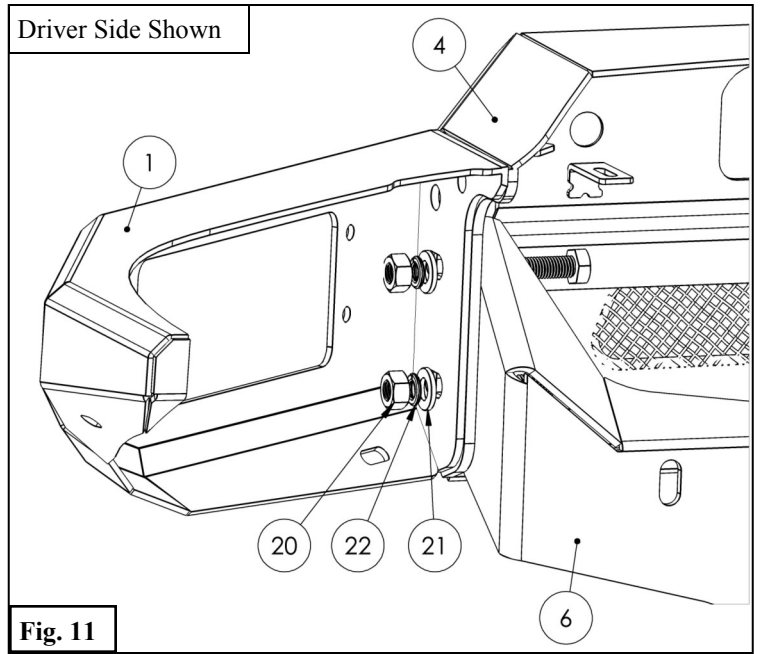
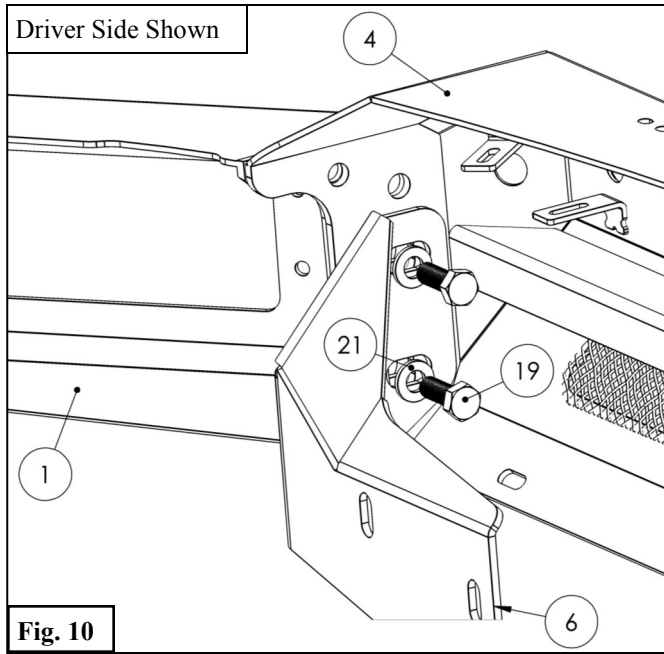

PARKING SENSOR INSTALLATION
***If not installing sensors, install Hole Plugs (18) into holes on bumper and proceed**

11. Remove the parking sensors from the OEM bumper.
12. Use the Sensor Tab (9) along with the supplied M6 Hardware (23-26) to install the sensors as shown in **Figure 12.**

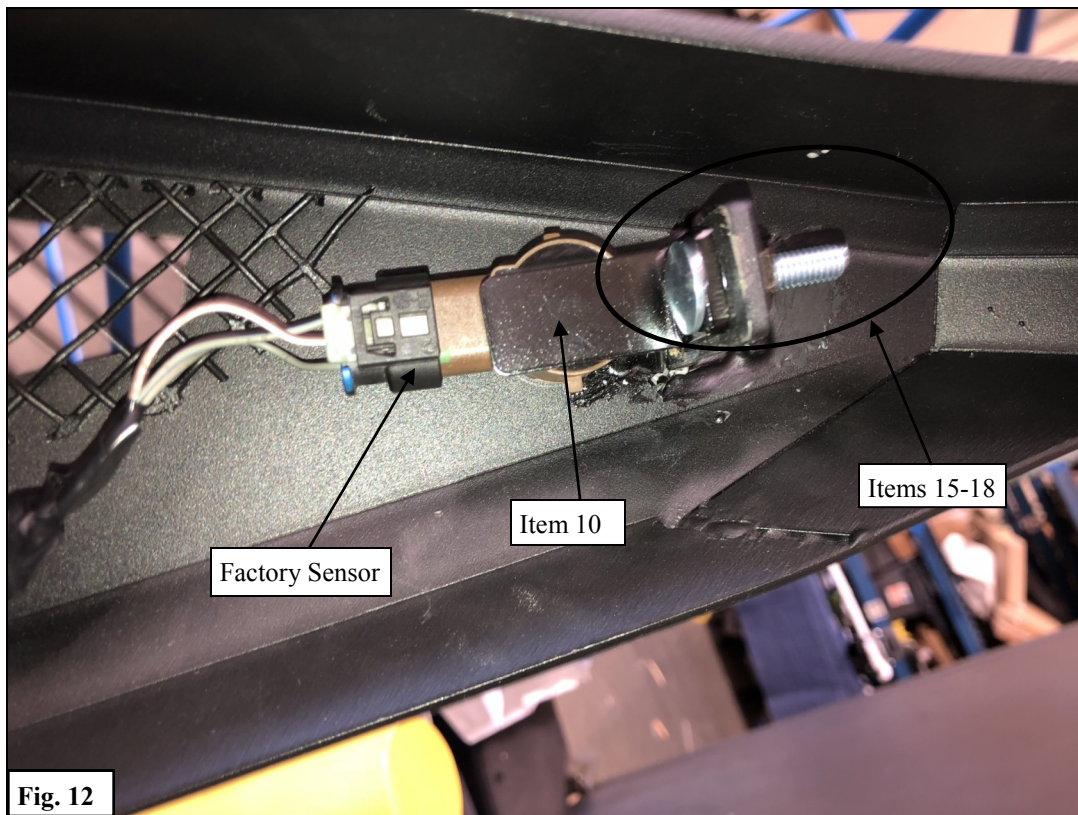

13. Install the Filler Triangles (15,16) on the vehicle just below the headlight using the supplied M8 Hardware. See **Figure 13**.
14. Install the preassembled bumper and mounting brackets along with the Valance Mounting Brackets (13,14) to the frame using the supplied M12 and M10 Hardware. See **Figure 14**.

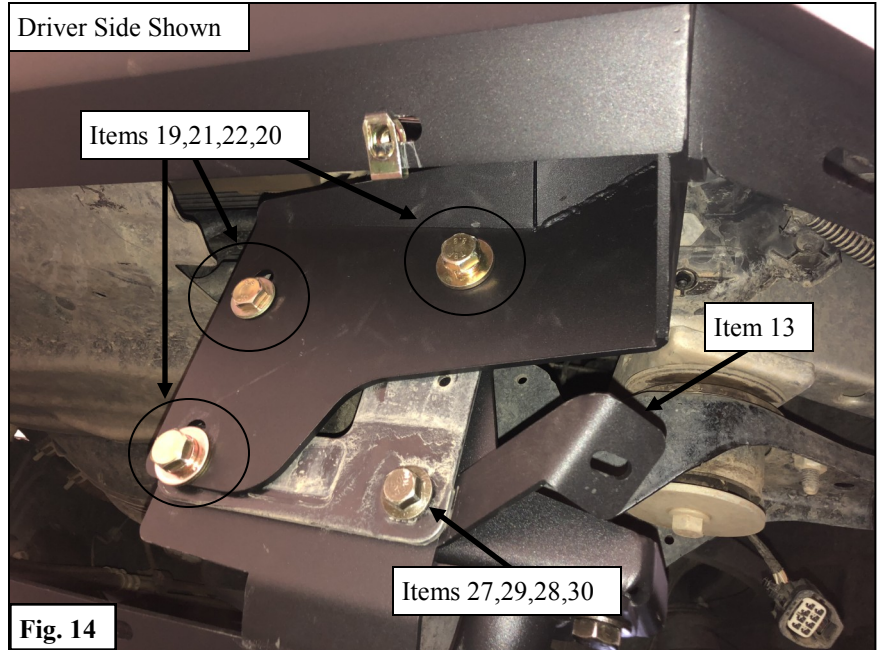
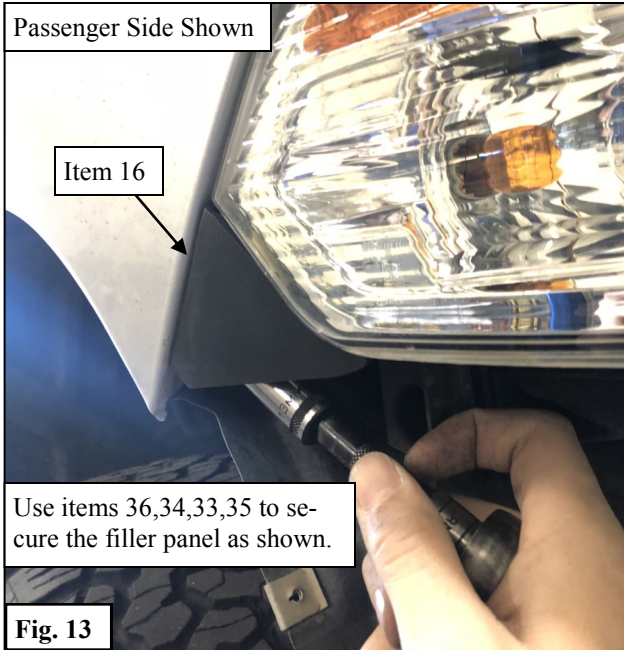

15. On the passenger side, use the M10 Bolt Plate (10) along with the M10 Hardware to attach the Side Strap (12) to the frame. See **Figure 15**.
16. On the driver side, use the M10 Nut Plate (8) along with the M10 Hardware to attach the Side Strap (11) to the frame. See **Figure 16**.

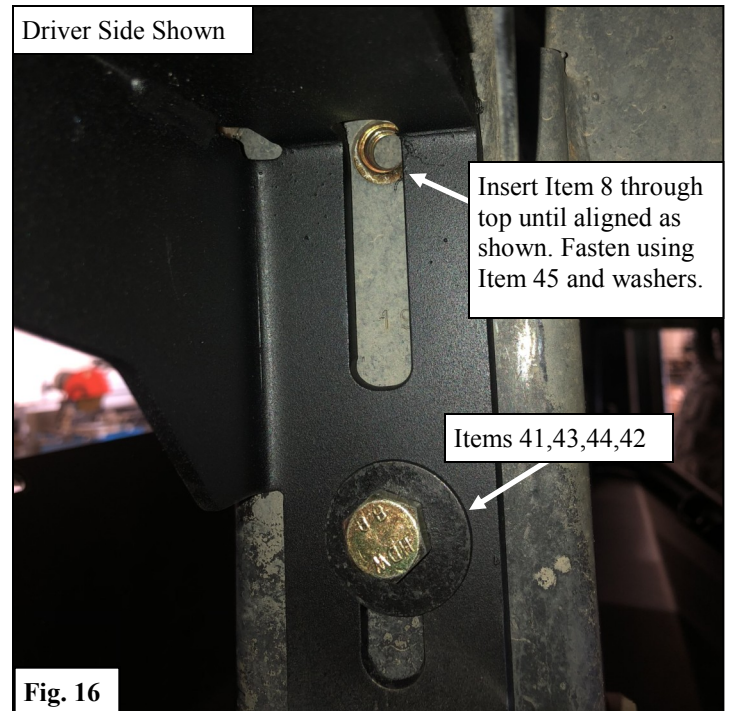
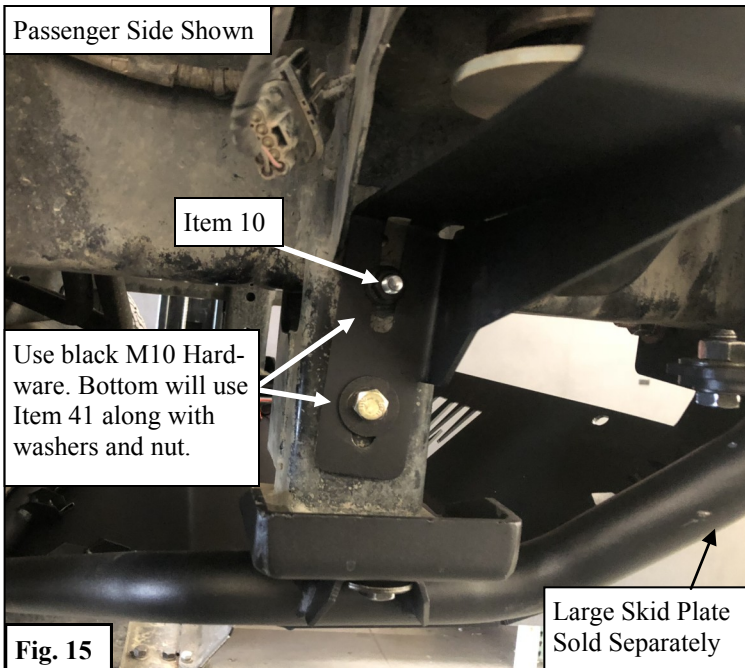

17. Attach both Side Straps (11,12) to the bumper using the supplied M8 Hardware. See **Figure 17**.
18. Attach the Mesh Side Covers (3) to the Bumper using the supplied M6 Hardware. See **Figures 18 & 19**.

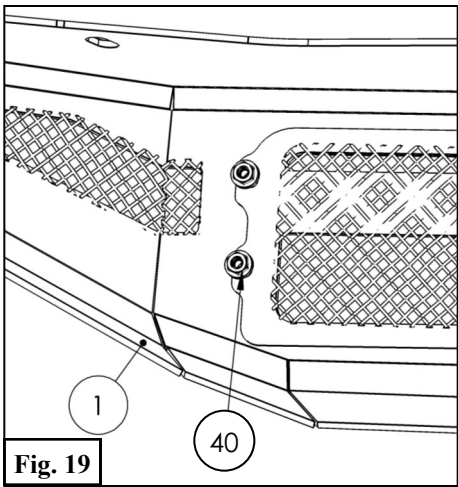
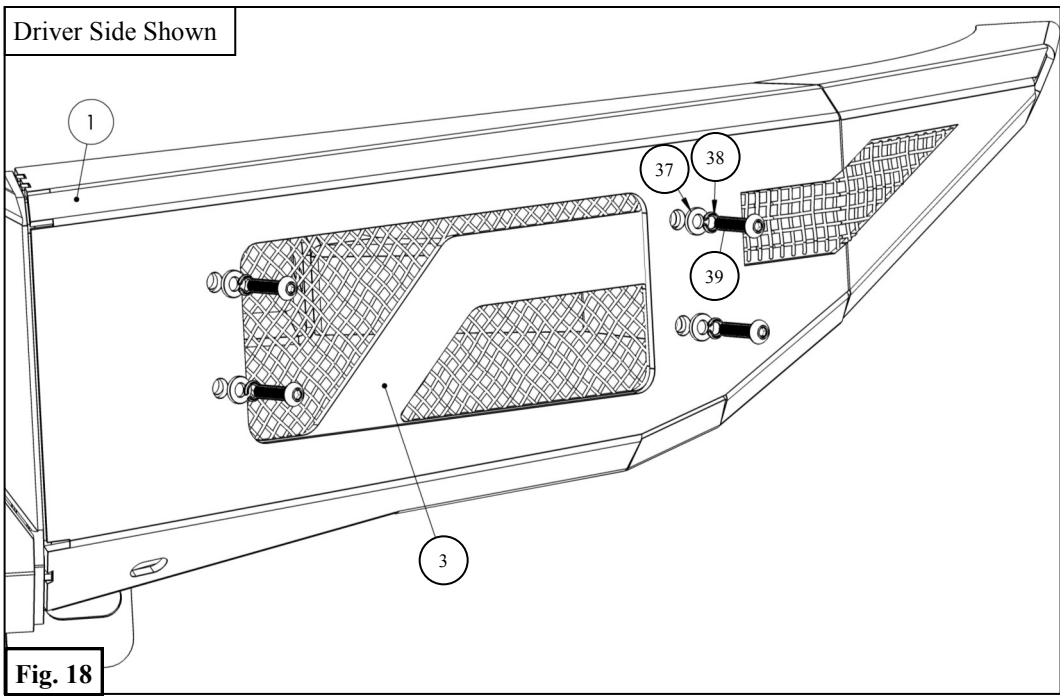
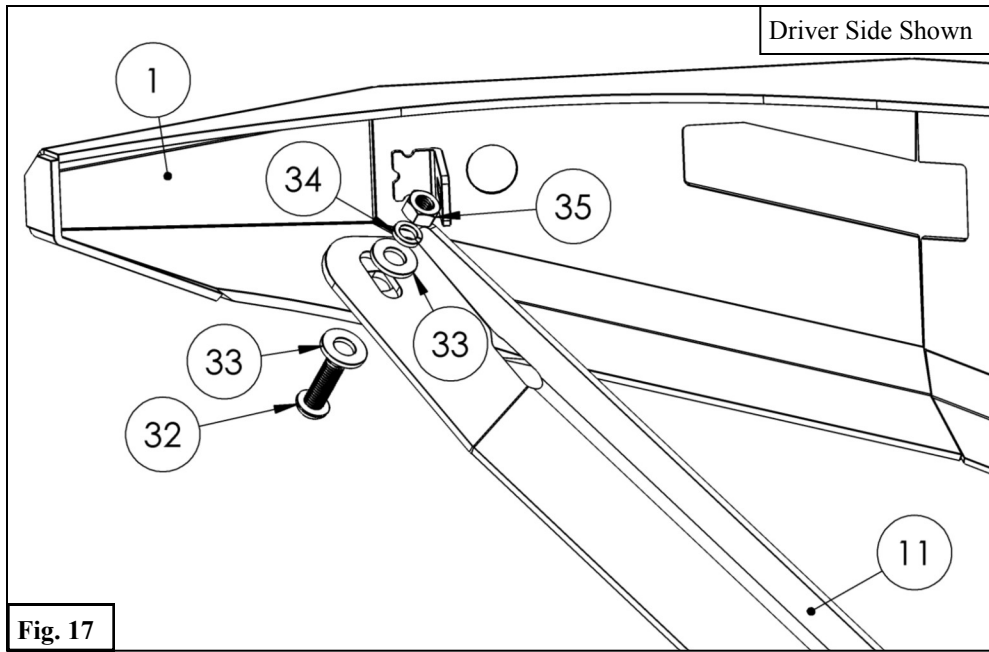

19. Align bumper as desired and torque all hardware as specified: M6 to 7 ft-lbs, M8 to 18 ft-lbs, M10 to 38 ft-lbs, M12 to 60 ft-lbs.

INSTALLATION COMPLETE



LED Light Bar Sold Separately

CARE INSTRUCTIONS

- REGULAR WAXING IS RECOMMENDED. DO NOT USE ANY TYPE OF POLISH OR WAX THAT MAY CONTAIN ABRASIVES.
- STAINLESS STEEL PRODUCTS CAN BE CLEANED WITH MILD SOAP AND WATER. STAINLESS STEEL POLISH SHOULD BE USED TO POLISH SMALL SCRATCHES.
- GLOSS BLACK FINISHES SHOULD BE CLEANED WITH MILD SOAP AND WATER

WESTIN

Westin Automotive Products, Inc.
320 W. Covina Blvd
San Dimas, Ca. 91773

Thank you for choosing Westin products
for additional installation assistance please call
Customer Service (800) 793-7846

www.westinautomotive.com



WARNING



Failure to follow these instructions could lead to death, personal injury, and / or property damage.

Failure to follow these instructions could lead to death, personal injury, and / or property damage.

FASTENERS:

All Westin supplied fasteners must be utilized and installed in accordance with the installation instructions and apply torque to the specifications as defined. **DOUBLE CHECK ALL FASTENERS BEFORE INITIAL USE, AND PERIODICALLY IN THE FUTURE TO ENSURE PROPER FUNCTION AND SAFETY.**

DRILLING:

Most Westin products do not require drilling for installation. If drilling is defined as required, use caution when drilling a vehicle. **FAILURE TO REVIEW AN AREA TO BE DRILLED MAY RESULT IN PERSONAL INJURY AND/OR INJURY TO OTHERS AS WELL AS VEHICLE DAMAGE.**

EYE PROTECTION:

ALWAYS WEAR SAFETY GLASSES OR GOGGLES DURING THE INSTALLATION PROCESS TO AVOID PERSONAL INJURY.

MAXIMUM TOWING/CARRYING CAPACITY: (if applicable)

The Westin Receiver Hitches will have a visible tow rating label affixed directly on the product. User should never exceed the vehicle manufacturers maximum tow and weight rating regardless of the capacity of the hitch. **FAILURE TO FOLLOW THESE GUIDELINES WILL VOID THE WESTIN WARRANTY AND MAY RESULT IN PERSONAL INJURY AND/OR INJURY TO OTHERS AS WELL AS VEHICLE DAMAGE.**

FOR CALIFORNIA RESIDENTS ONLY-PROP 65 WARNING:

Some products may contain chemicals such as DEHP, which can cause cancer, birth defects or other reproductive harm. For more info go to www.p65warnings.ca.gov



Westin Automotive Products, Inc.
320 W. Covina Blvd
San Dimas, Ca. 91773