

INSTALLATION INSTRUCTIONS

PRO-SERIES FRONT BUMPER



APPLICATION: 2018-2020 FORD F-150

PART NUMBER: 58-411065

CONTENT			
ITEM	QUANTITY	DESCRIPTION	TOOLS NEEDED
1	1	FRONT BUMPER	ALLEN
2	1	WINCH TRAY	10MM SOCKET
3	1	LED COVER	10MM WRENCH
4	1	DRIVER LED BRACKET	19MM SOCKET
5	1	PASSENGER LED BRACKET	19MM WRENCH
6	1	DRIVER MAIN BRACKET	RATCHET
7	1	PASSENGER MAIN BRACKET	TORQUE WRENCH
8	10	M12 SERRATED FLANGE NUT	18MM SOCKET
9	12	M12 HEX HEAD BOLT	18MM WRENCH
10	4	M12 LOCK WASHER	21MM SOCKET
11	22	M12 FLAT WASHER	
12	4	M6 HEX HEAD BOLT	
13	8	M6 FLAT WASHER	
14	8	M6 SERRATED FLANGE NUT	
15	4	M6 COUNTERSUNK SOCKET HEAD SCREW	
16	2	M12 DOUBLE NUT PLATE	
17	2	M12 BOLT PLATE	

ANTI-SEIZE LUBRICANT MUST BE USED ON ALL STAINLESS STEEL FASTENERS TO PREVENT THREAD DAMAGE AND GALLING

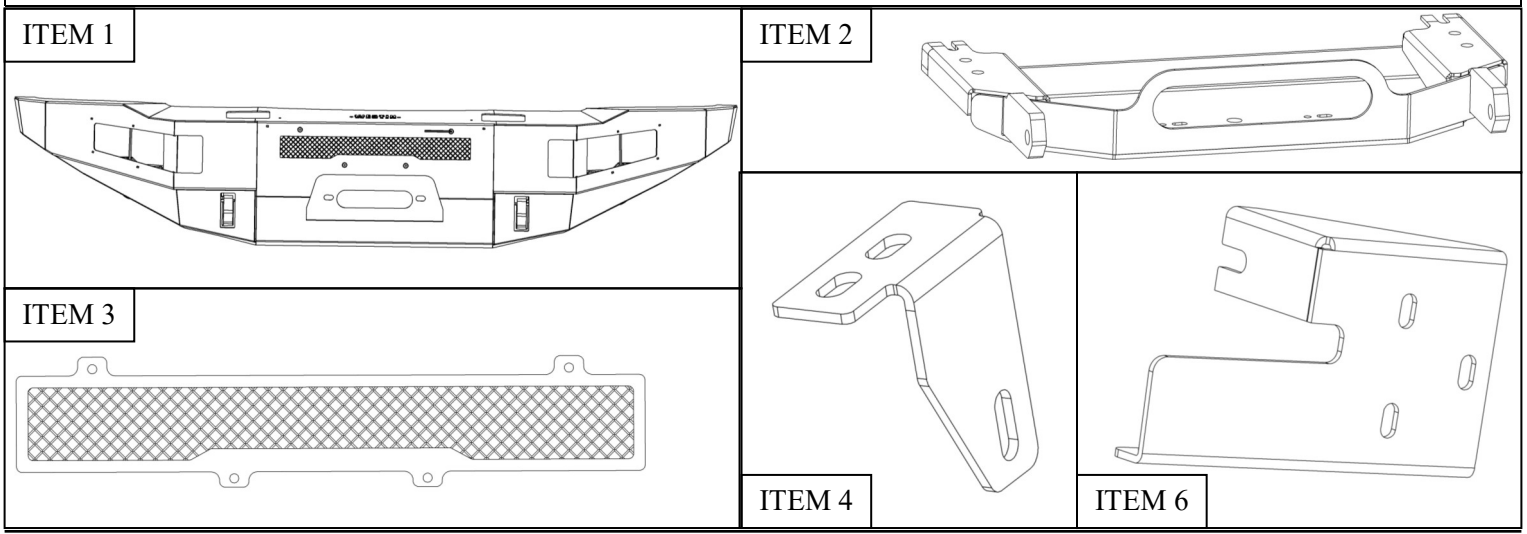

WESTIN Westin Automotive Products, Inc.
320 W. Covina Blvd
San Dimas, Ca. 91773

Thank you for choosing Westin products
for additional installation assistance please call
Customer Service (800) 793-7846
www.westinautomotive.com

PROCEDURE

1. Remove contents from box, verify if all parts listed are present and free from damage.
Carefully read and understand all instructions before attempting installation.
Failure to identify damage before installation could lead to a rejection of any claim.

2. Remove plastic caps from stock bumper. See **Figure 1** for reference.
3. Remove the three bolts indicated in **Figures 2 & 3** from each side of the vehicle.
4. Remove original bumper making sure to disconnect any electrical connections to the bumper.

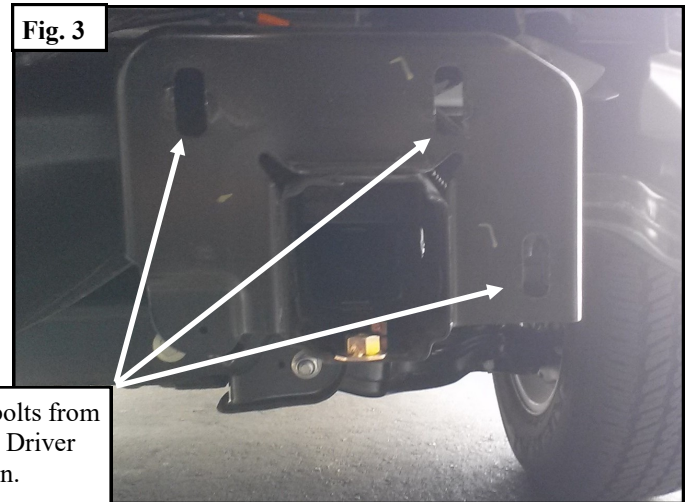
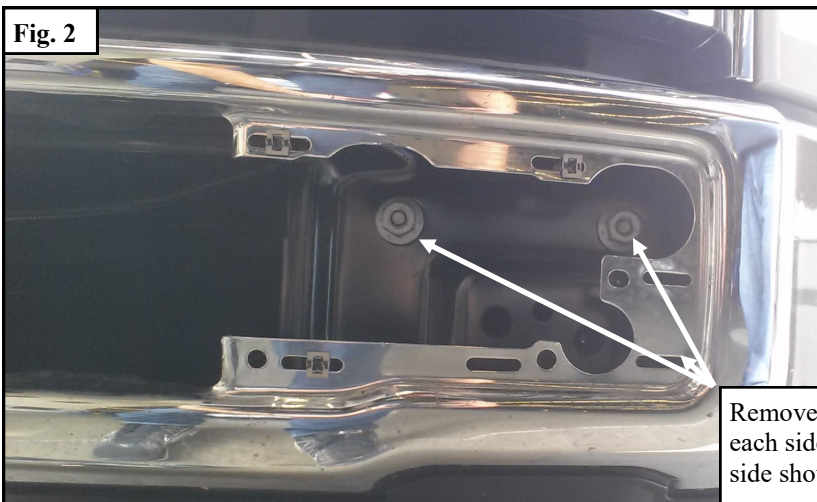

Remove bolts from each side. Driver side shown.

WESTIN

Westin Automotive Products, Inc.
320 W. Covina Blvd
San Dimas, Ca. 91773

5. Remove the two small trim screws from the plastic trim pieces on either side of the vehicle. See **Figure 4** for reference.
6. Carefully pull back the trim to access the two bolts behind it for the air dam; remove these two bolts along with the bolt on the front facing side of the air dam. See **Figures 5 & 6**. Remove the air dam from both sides.

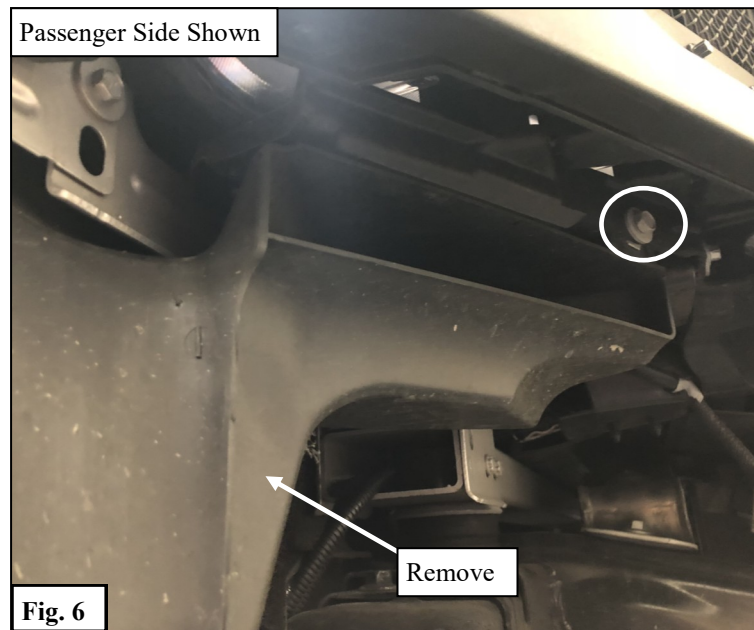
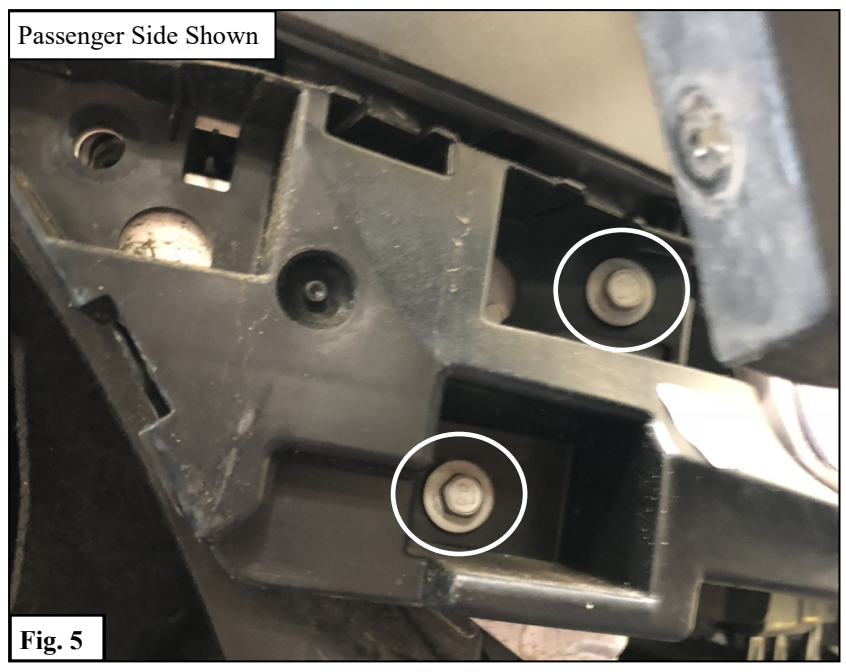
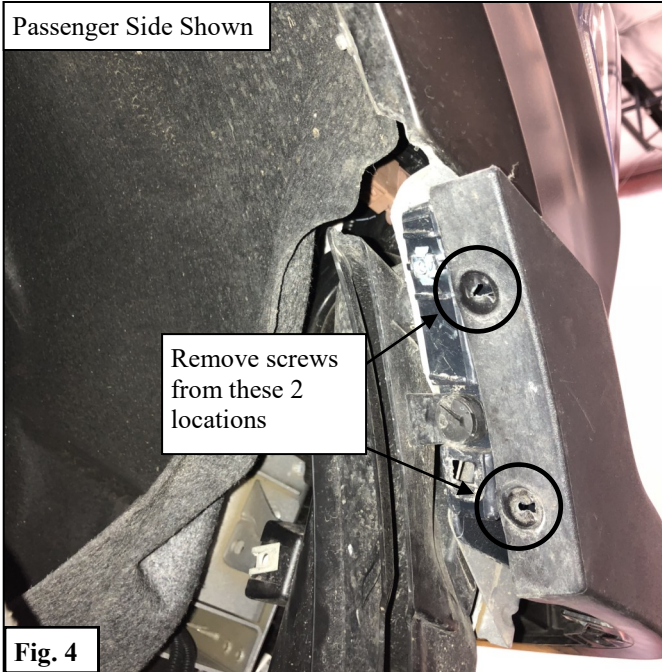

7. Reinstall the plastic trim piece as removed in **Step 5**.
8. Loosely install the Winch Tray (2) to the frame using the supplied M12 Bolt Plate (17)
9. Install the supplied Driver and Passenger Main Brackets (6, 7) onto the frame using the supplied M12 Hardware (8-11, 16). See **Figures 7-9** for reference. *Note: The frame is "sandwiched" by the Winch Tray (2) and the Driver and Passenger*

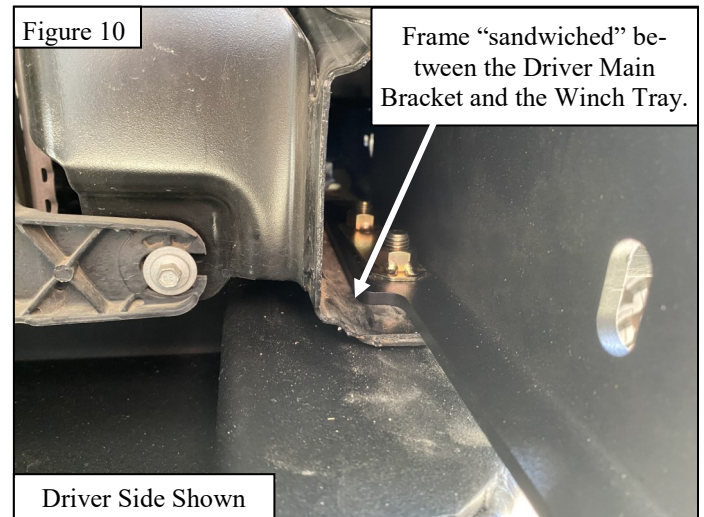
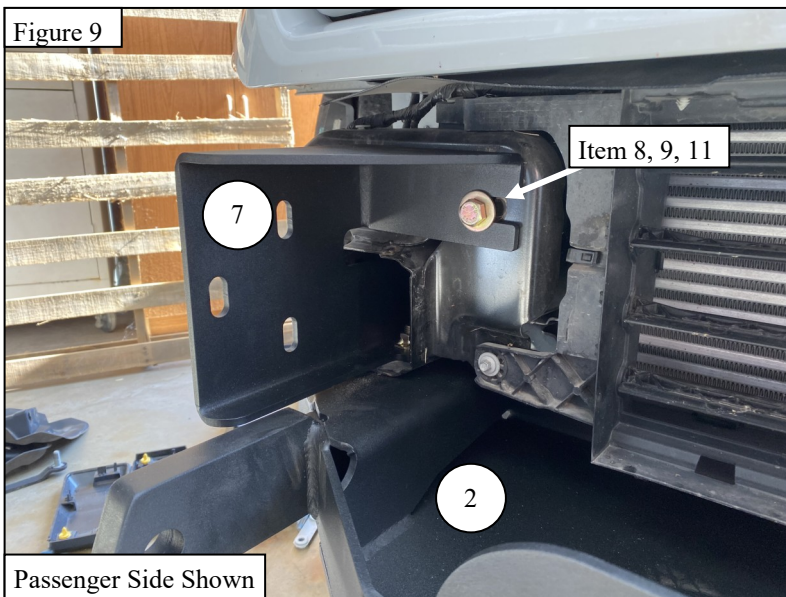
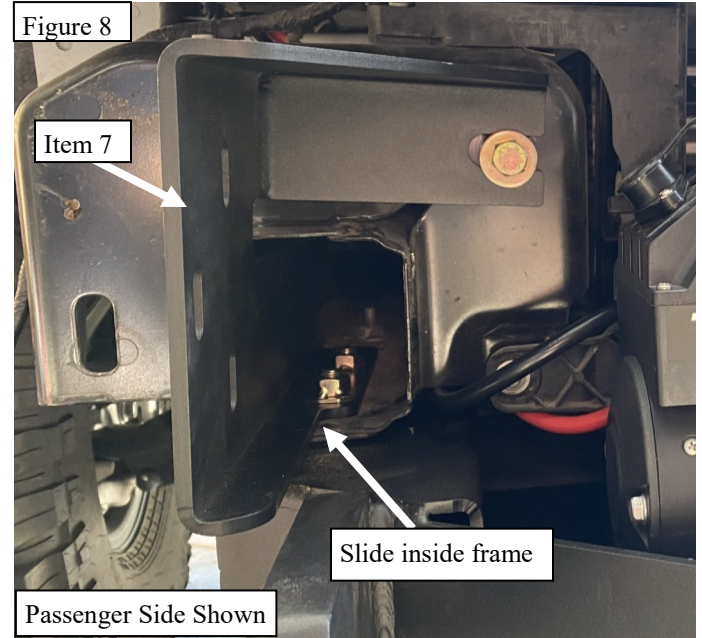
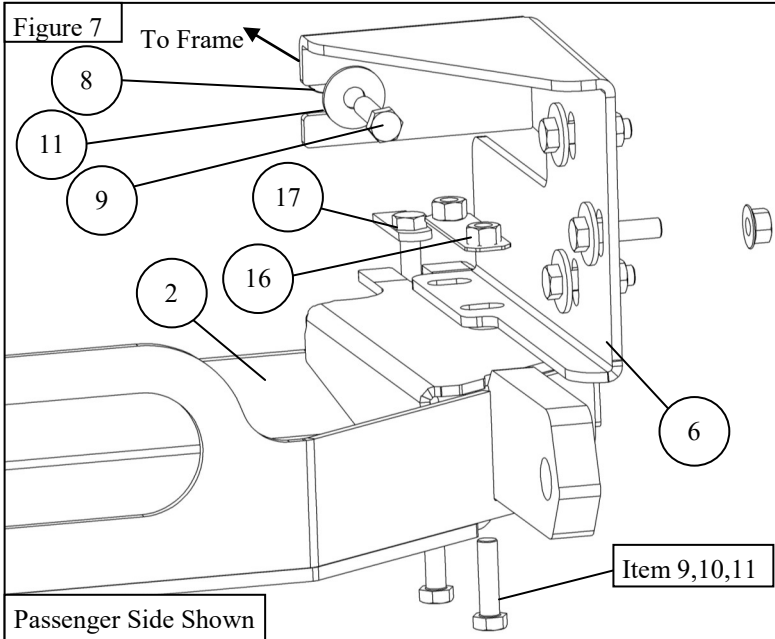

9. Mount your winch and winch accessories at this time.
10. If installing a light bar, install using the supplied LED light brackets and supplied M6 hardware, if applicable. Install light per manufacturers recommendation. See **Figure 9** for reference.

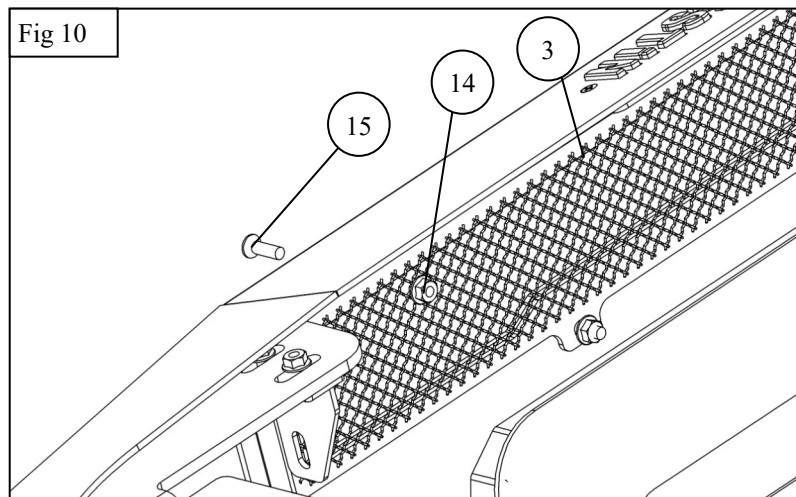
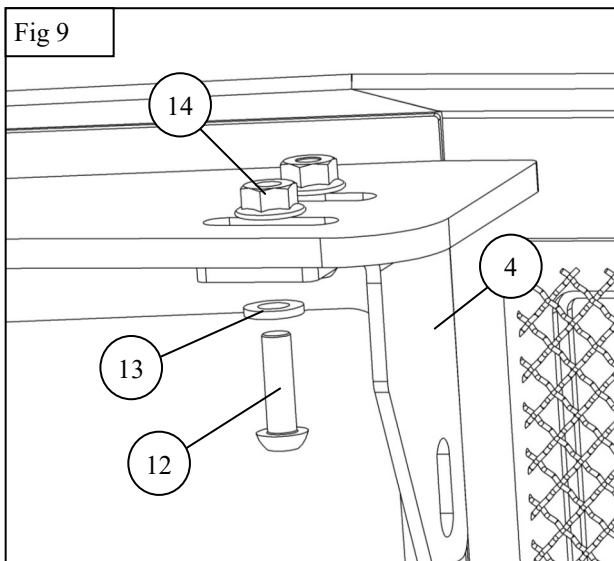

19. With help, loosely assemble the bumper assembly to the main mounting brackets using supplied M12 hardware. See **Figure 11** for reference.
20. Adjust as needed and tighten all hardware as specified: M6 to 5-7 ft-lbs, M12 to 50 ft-lbs.

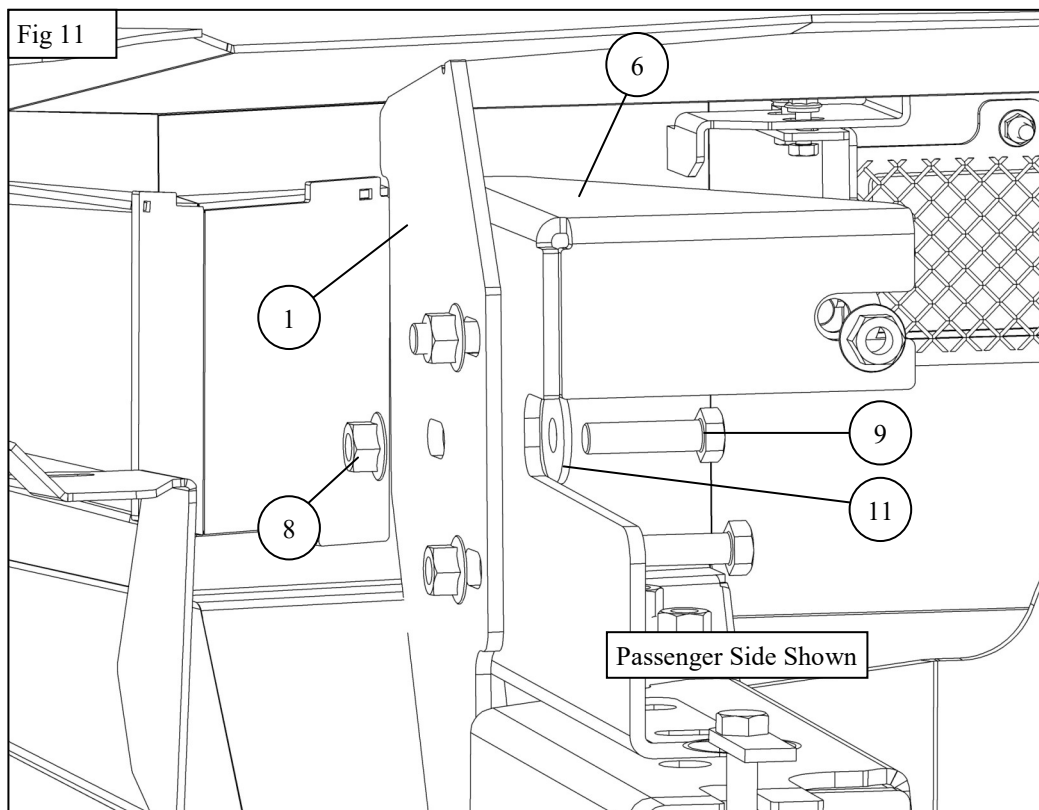

INSTALLATION COMPLETE



CARE INSTRUCTIONS

- REGULAR WAXING IS RECOMMENDED. DO NOT USE ANY TYPE OF POLISH OR WAX THAT MAY CONTAIN ABRASIVES.
- STAINLESS STEEL PRODUCTS CAN BE CLEANED WITH MILD SOAP AND WATER. STAINLESS STEEL POLISH SHOULD BE USED TO POLISH SMALL SCRATCHES.
- GLOSS BLACK FINISHES SHOULD BE CLEANED WITH MILD SOAP AND WATER.

WESTIN

Westin Automotive Products, Inc.
320 W. Covina Blvd
San Dimas, Ca. 91773

Thank you for choosing Westin products
for additional installation assistance please call
Customer Service (800) 793-7846

www.westinautomotive.com



WARNING



Failure to follow these instructions could lead to death, personal injury, and / or property damage.

Failure to follow these instructions could lead to death, personal injury, and / or property damage.

FASTENERS:

All Westin supplied fasteners must be utilized and installed in accordance with the installation instructions and apply torque to the specifications as defined. **DOUBLE CHECK ALL FASTENERS BEFORE INITIAL USE, AND PERIODICALLY IN THE FUTURE TO ENSURE PROPER FUNCTION AND SAFETY.**

DRILLING:

Most Westin products do not require drilling for installation. If drilling is defined as required, use caution when drilling a vehicle. **FAILURE TO REVIEW AN AREA TO BE DRILLED MAY RESULT IN PERSONAL INJURY AND/OR INJURY TO OTHERS AS WELL AS VEHICLE DAMAGE.**

EYE PROTECTION:

ALWAYS WEAR SAFETY GLASSES OR GOGGLES DURING THE INSTALLATION PROCESS TO AVOID PERSONAL INJURY.

MAXIMUM TOWING/CARRYING CAPACITY: (if applicable)

The Westin Receiver Hitches will have a visible tow rating label affixed directly on the product. User should never exceed the vehicle manufacturers maximum tow and weight rating regardless of the capacity of the hitch. **FAILURE TO FOLLOW THESE GUIDELINES WILL VOID THE WESTIN WARRANTY AND MAY RESULT IN PERSONAL INJURY AND/OR INJURY TO OTHERS AS WELL AS VEHICLE DAMAGE.**

FOR CALIFORNIA RESIDENTS ONLY-PROP 65 WARNING:

Some products may contain chemicals such as DEHP, which can cause cancer, birth defects or other reproductive harm. For more info go to www.p65warnings.ca.gov



Westin Automotive Products, Inc.
320 W. Covina Blvd
San Dimas, Ca. 91773