



INSTALLATION INSTRUCTIONS

OUTLAW FRONT BUMPER

APPLICATION:

2013-2018 Dodge Ram 1500

PART NUMBER:

58-61025

ITEM	QUANTITY	DESCRIPTION	TOOLS NEEDED
1	1	OUTLAW FRONT BUMPER	18MM WRENCH
2	1	UPPER SKID PLATE	5MM ALLEN WRENCH
3,4	2	MESHED CORNER COVER, DRIVER (3) AND PASSENGER (4)	13MM SOCKET
5,6	2	FILLER TRIANGLE, DRIVER (5) AND PASSENGER (6)	17MM SOCKET
7,8	2	FRAME BRACKET, DRIVER (7) AND PASSENGER (8)	19MM SOCKET
9,10	2	LED SLIDER BRACKET, DRIVER (9) AND PASSENGER (10)	13MM WRENCH
11,12	2	LED L-BRACKET, DRIVER (11) AND PASSENGER (12)	17MM WRENCH
13	2	MESHED SIDE LED COVER	19MM WRENCH
14	8	M8 BUTTON HEAD BOLT (BLACK ZINC)	10MM SOCKET
15	20	SMALL M8 FLAT WASHER (BLACK ZINC)	10MM WRENCH
16	18	M8 SPLIT LOCK WASHER (BLACK ZINC)	PLYER TOOL
17	4	M8 SERRATED FLANGE HEX NUT (BLACK ZINC)	RATCHET
18	8	M8 CARRIAGE SCREW (BLACK ZINC)	TORQUE WRENCH
19	10	M8 HEX NUT (BLACK ZINC)	
20	4	SHORT M12 HEX BOLT (BLACK ZINC)	
21	10	M12 HEX NUT (BLACK ZINC)	
22	20	M12 FLAT WASHER (BLACK ZINC)	
23	10	M12 SPLIT LOCK WASHER (BLACK ZINC)	
24	6	LONG M12 HEX BOLT (BLACK ZINC)	
25	2	M10 HEX BOLT (BLACK ZINC)	
26	4	M10 FLAT WASHER (BLACK ZINC)	
27	2	M10 SPLIT LOCK WASHER (BLACK ZINC)	
28	2	M10 HEX NUT (BLACK ZINC)	
29	2	M8 HEX BOLT (BLACK ZINC)	
30	8	LARGE M8 FLAT WASHER (BLACK ZINC)	
31	4	M8 U-CLIP (YELLOW ZINC)	

ANTI-SEIZE LUBRICANT MUST BE USED ON ALL STAINLESS STEEL FASTENERS TO PREVENT THREAD DAMAGE AND GALLING

CARE INSTRUCTIONS

- REGULAR WAXING IS RECOMMENDED. DO NOT USE ANY TYPE OF POLISH OR WAX THAT MAY CONTAIN ABRASIVES.
- STAINLESS STEEL PRODUCTS CAN BE CLEANED WITH MILD SOAP AND WATER. STAINLESS STEEL POLISH SHOULD BE USED TO POLISH SMALL SCRATCHES.
- GLOSS BLACK FINISHES SHOULD BE CLEANED WITH MILD SOAP AND WATER.

WESTIN Westin Automotive Products, Inc.
320 W. Covina Blvd
San Dimas, Ca. 91773

Thank you for choosing Westin products
for additional installation assistance please call
Customer Service (800) 793-7846

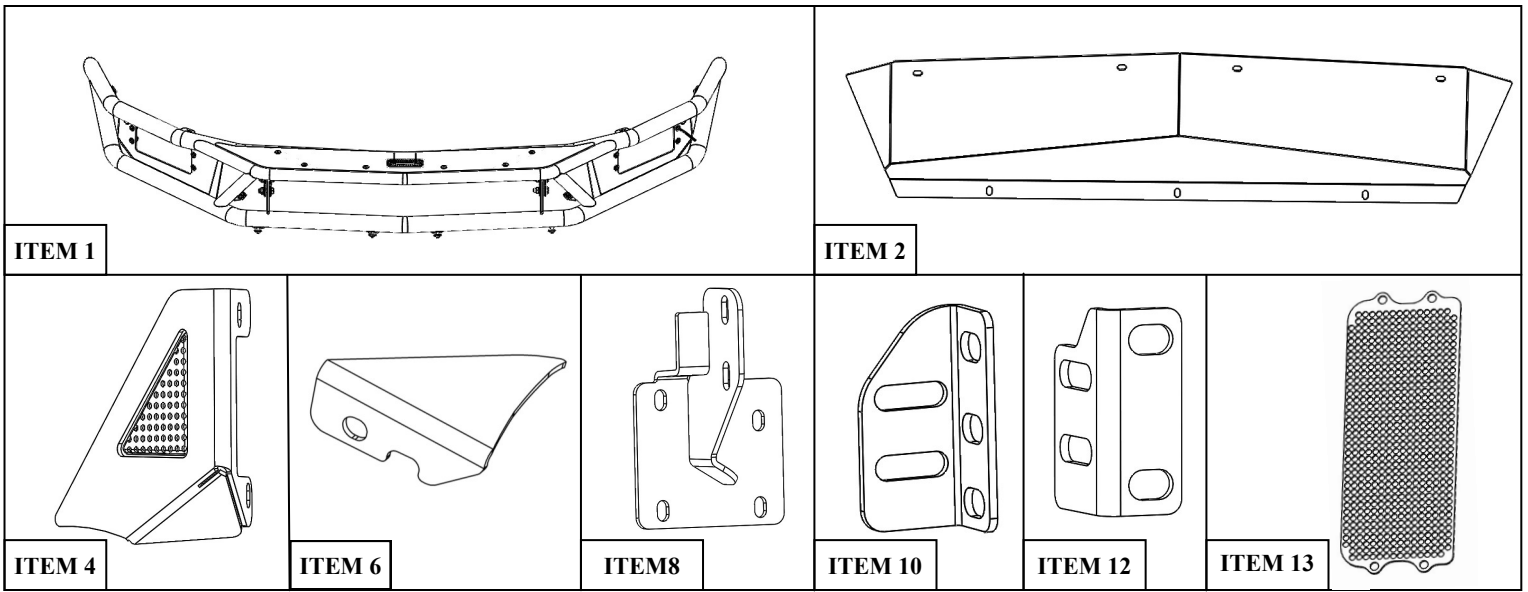

PROCEDURE

1. Remove contents from box, verify if all parts listed are present and free from damage. Carefully read and understand all instructions before attempting installation. **Failure to identify damage before installation could lead to a rejection of any claim.**
2. Disconnect any electrical connectors that are attached to front bumper. Including parking sensor harness, fog lights, etc.
3. Remove tow hooks if equipped.
4. Locate original nuts fastening bumper to frame and remove using 18mm wrench. See **Figures 1 & 2**.
5. Carefully remove bumper assembly. See **Figure 3**.

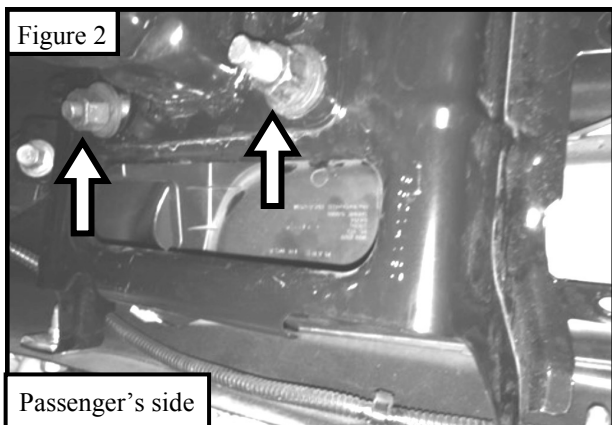
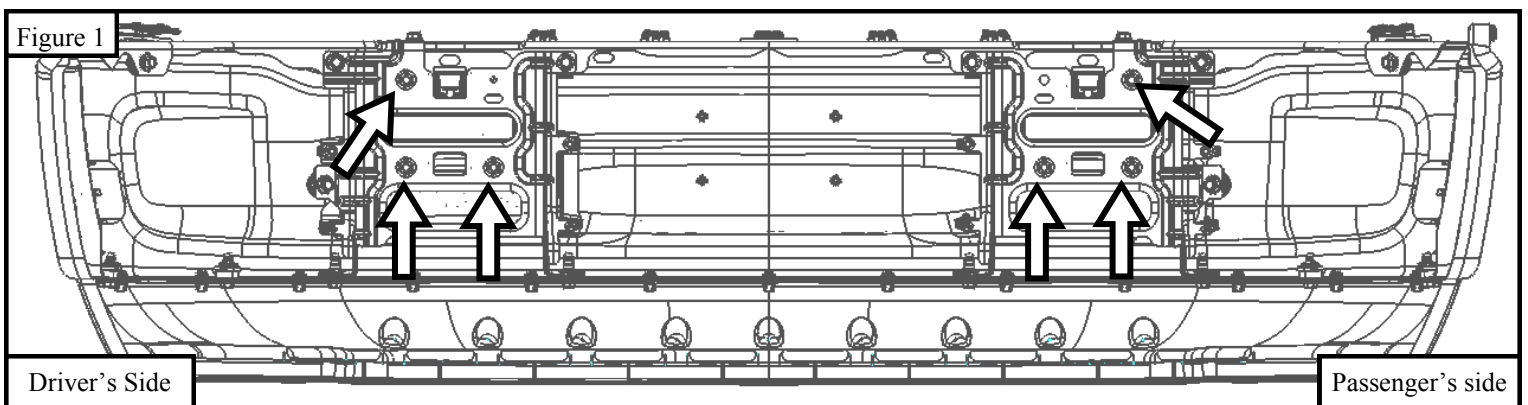

5. Remove filler panel between bumper and grille. Start by removing screws around fender area fastening the filler panel to the body of the truck. Use a 10mm socket. See **Figure 4–5**.

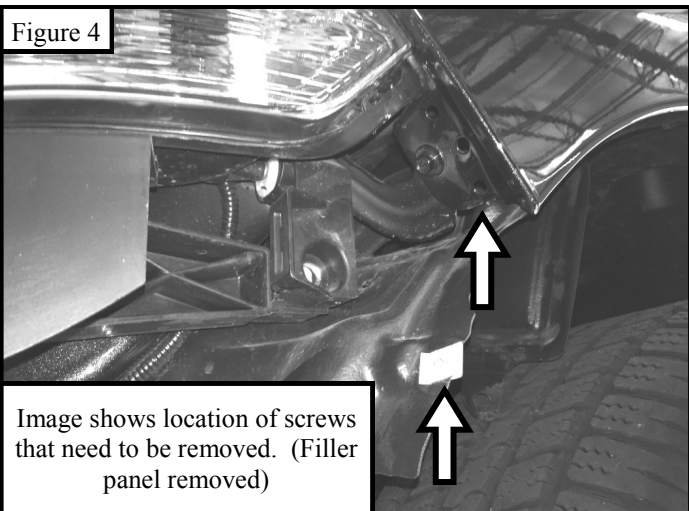

6. After all screws holding filler panel have been removed, carefully pull starting from either side and un-clip tabs holding filler panel to the truck.

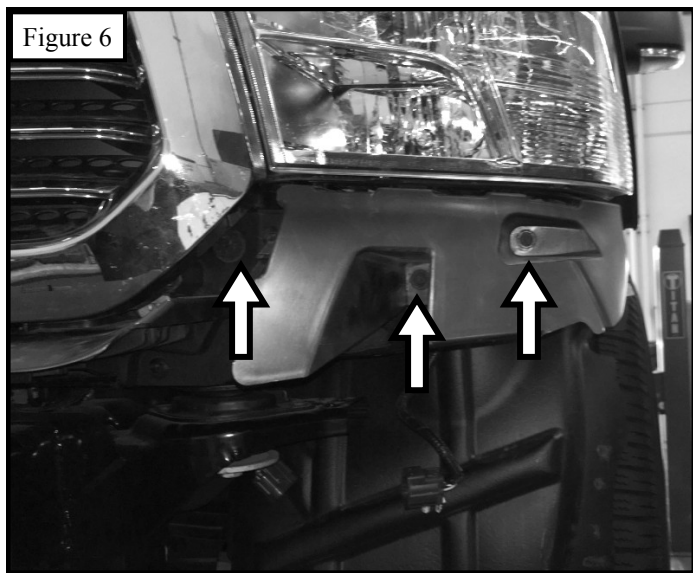
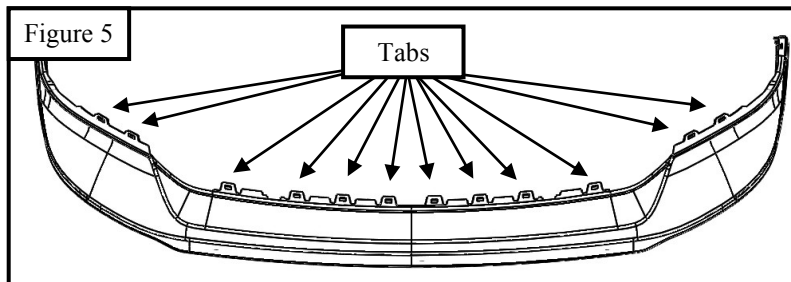

7. Remove plastic pieces behind filler panel using 10mm socket. Once all screws have been removed, carefully pull plastic pieces and un-clip tabs around grille area. See **Figures 6-7**.

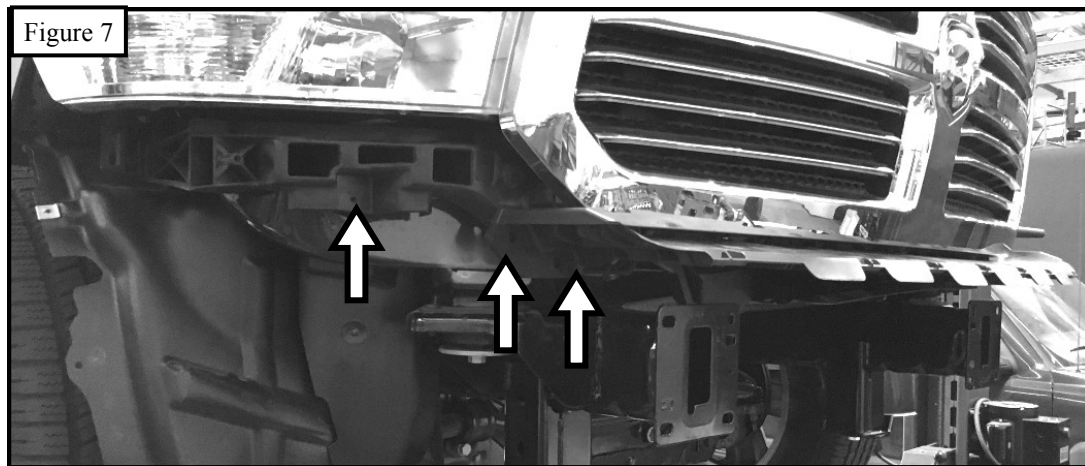

7. Install components 7 and 8 according to **Figure 8**. Use items 25 –28 for the top-inner bolts and items 21-24 for the rest of the bolts.

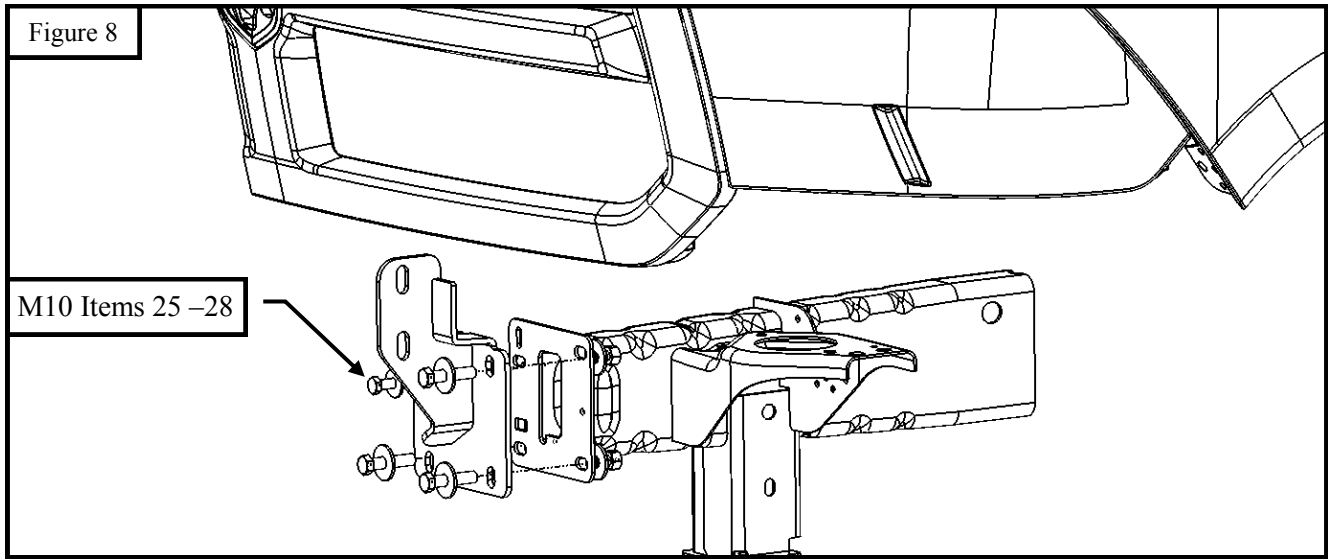

8. Proceed to install center light bar brackets and light bar (s). Items 9-12 can be mounted in different configurations in order to have the necessary adjustment for various “30” inch light bar overall lengths. See **Figure 9-11**.

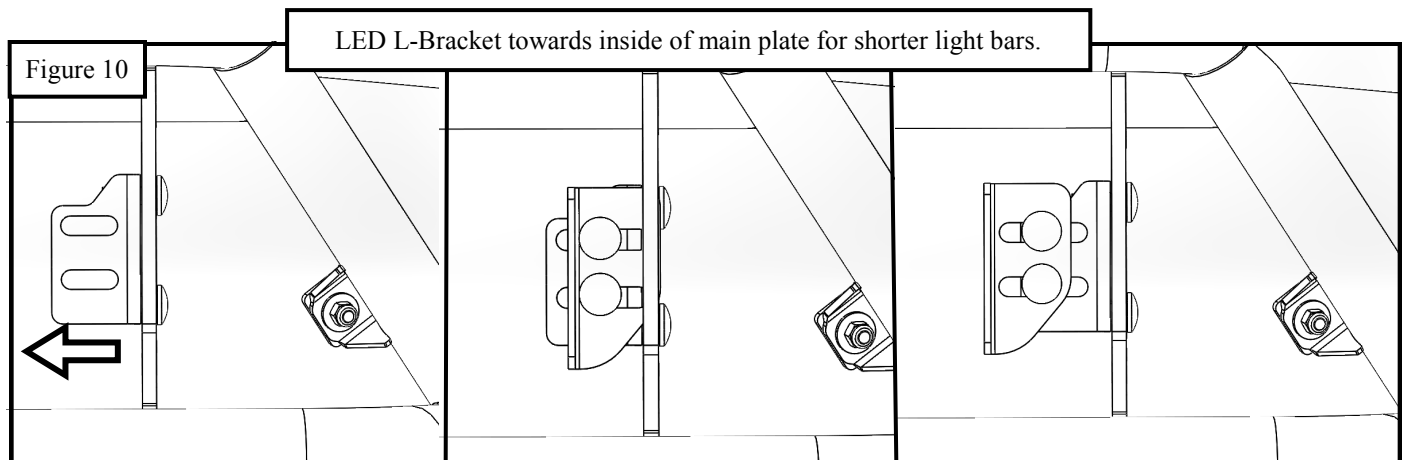
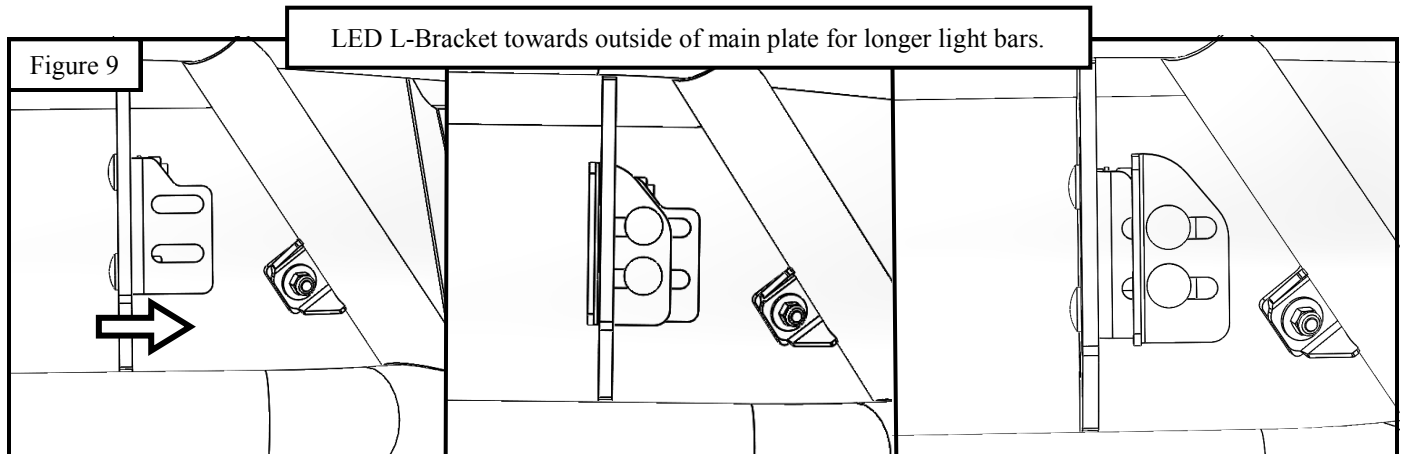

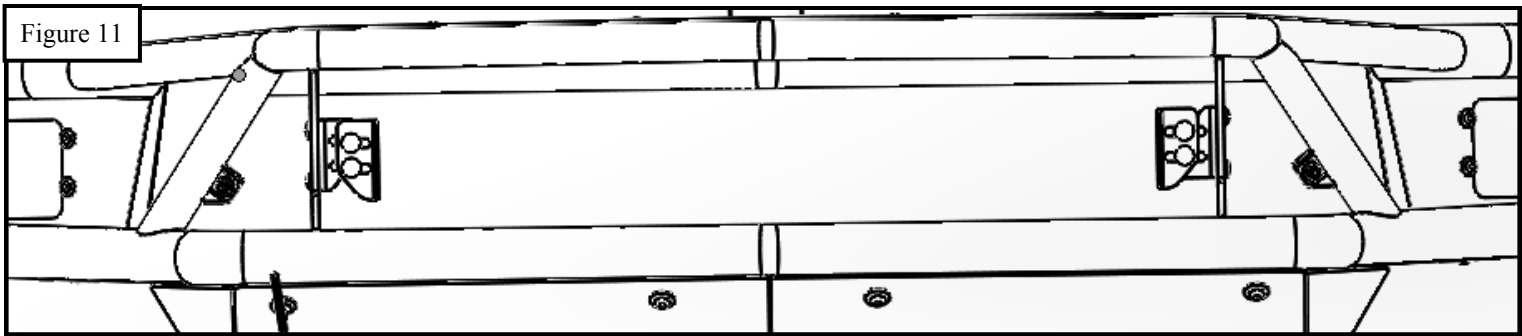
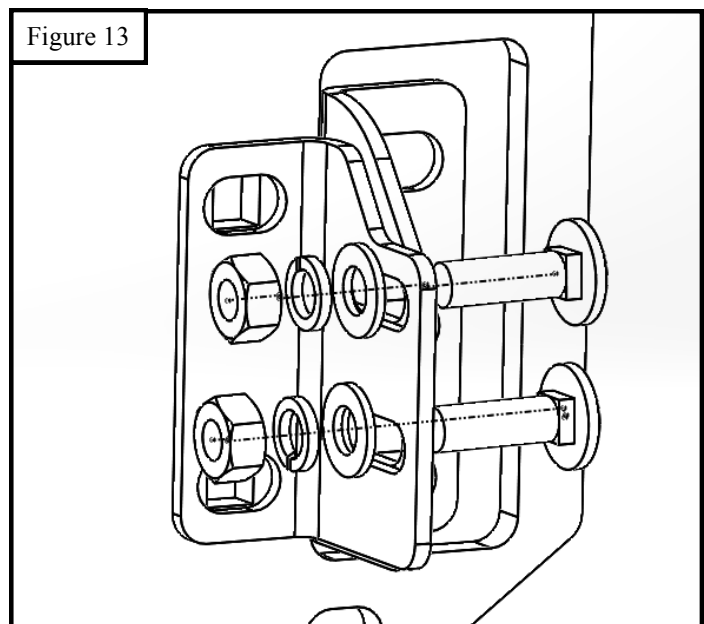
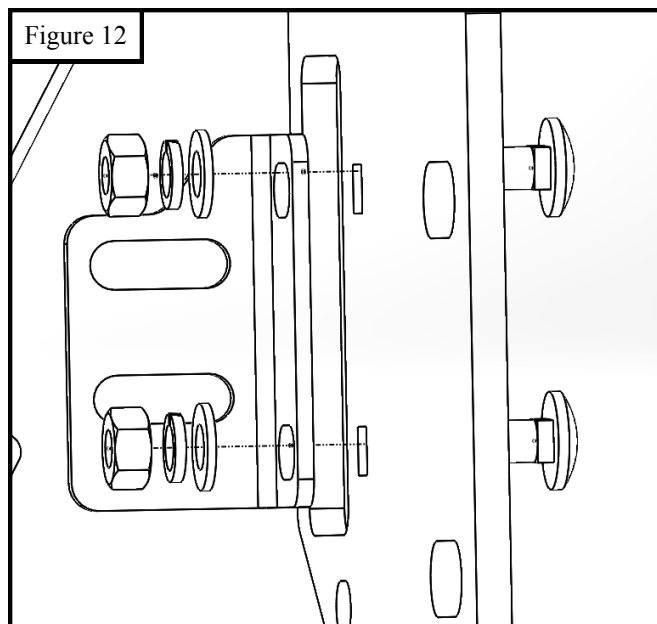
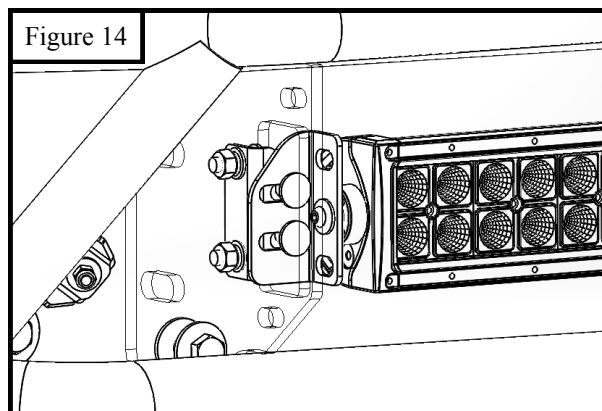

Figure 11 is an example that shows the LED brackets towards the inside adjusted in for the shortest light bar configuration.



9. Using items 15,16,18 and 19 fasten LED L-Brackets (11 & 12) to main plate. Do not tighten. See **Figure 12**.
10. Using items 15,16,18 and 19 fasten LED Slider Brackets (9 & 10) to LED L-Bracket. Do not tighten. See **Figure 13**.
11. Using hardware included in the LED light bar hardware kit, fasten to bracket according to **Figures 14-15**.
12. Position light bar as desired and tighten all M8 hardware to 15-18 ft-lbs.



Single "Double Row" Light Bar Configuration

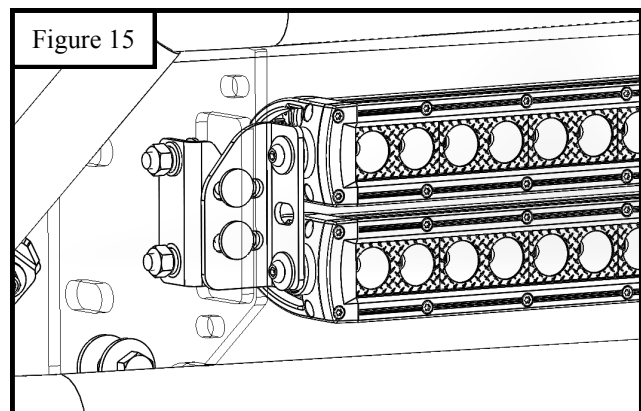

Double "Single Row" Light Bar Configuration

13. Position the meshed corner covers (3 & 4) as seen in **Figures 16 & 17**.

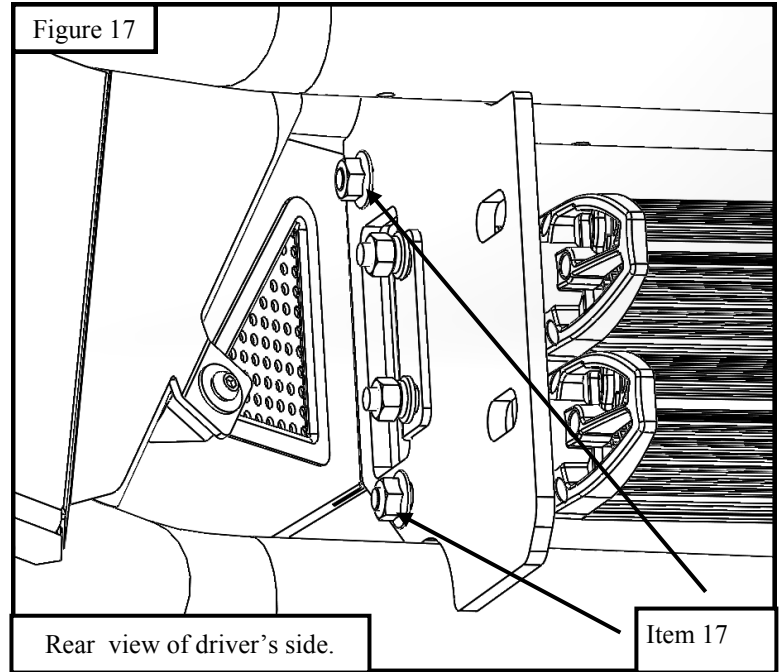
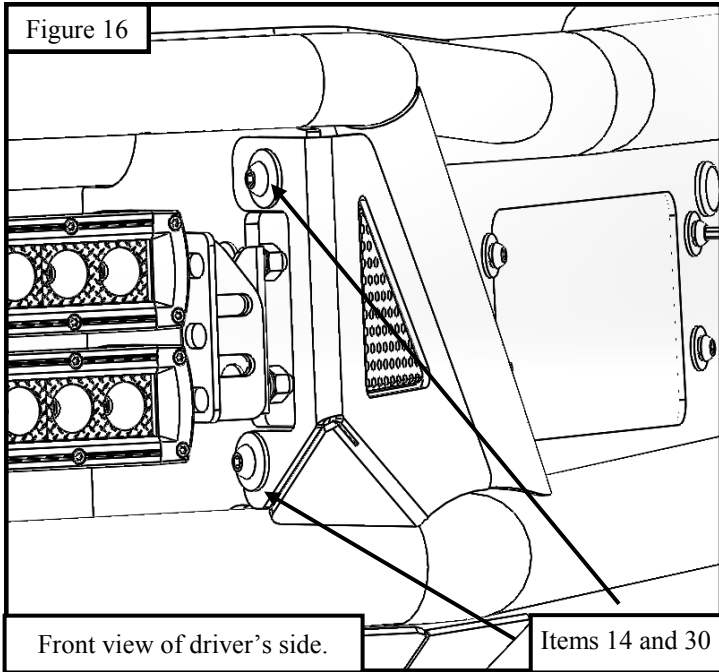

14. Using item 17, fasten corner covers into position. The serration on the nut should lock the nut in position allowing the installer to tighten button head bolts from the front using a 5mm Allen wrench. See **Figure 17**.

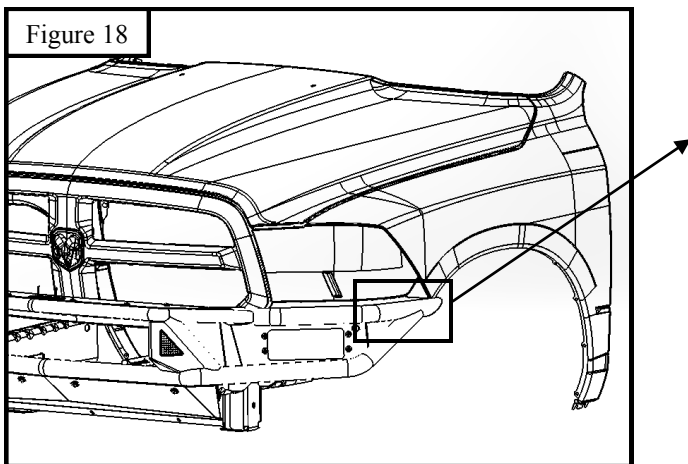

15. Install item 5 and 6 to fill in the space between headlight and fender. See **Figure 18-19**.

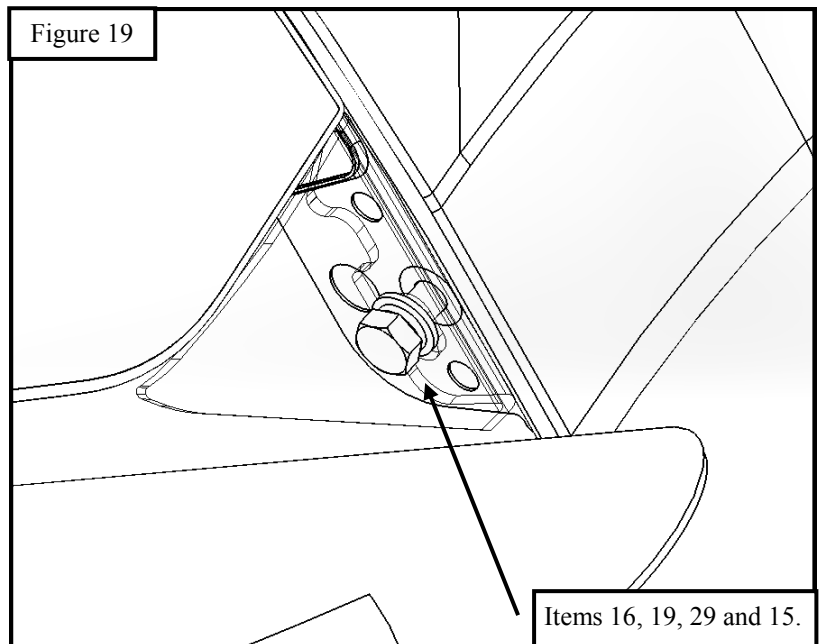

16. Using supplied M12 hardware (20-23) , mount bumper to frame brackets (7 & 8) according to **Figures 20, 21**. Tighten M12 hardware to 50-55 ft-lbs.

Figure 20

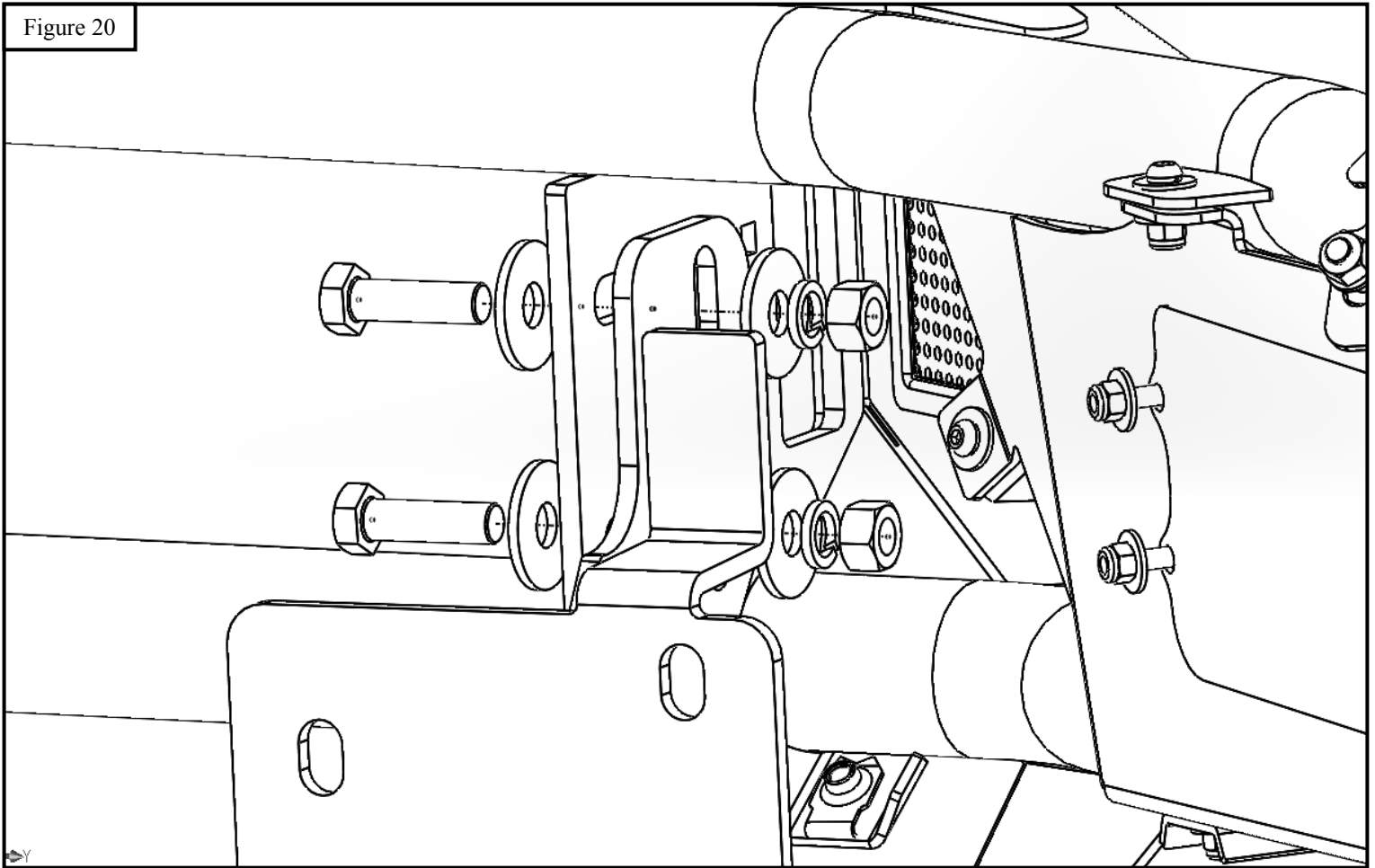
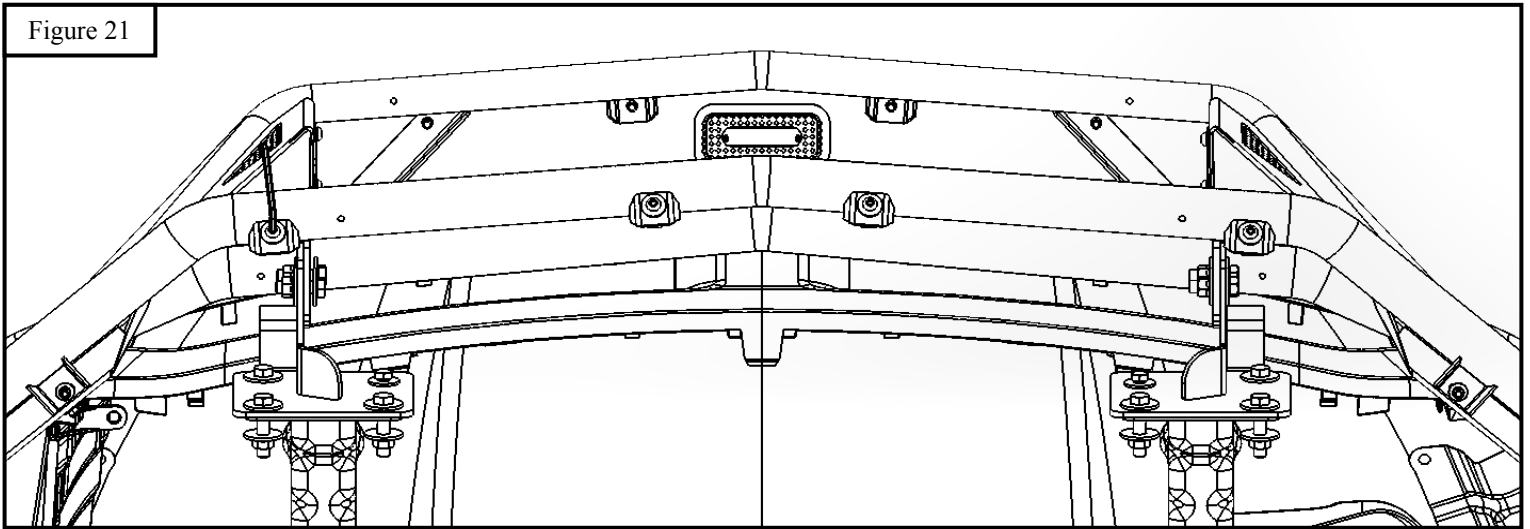
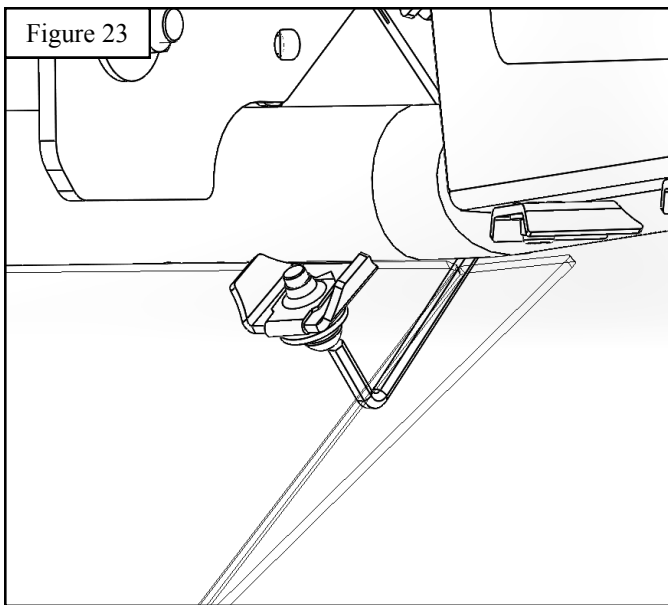
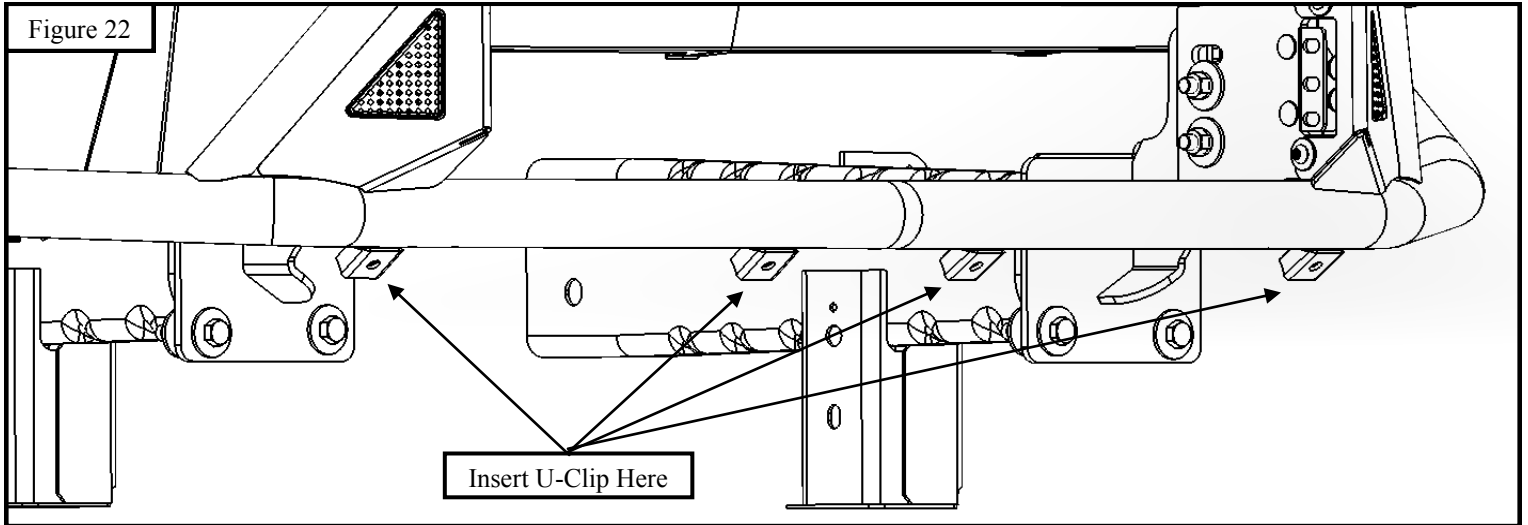

Figure 21



17. Install M8 U-clips (31) on 4 tabs on lower tube of bumper according to **Figures 22 ,23.**



17. Install upper skid plate (2) on bumper using items 14, 30, and 16 according to **Figure 24.**
18. Torque all loose hardware according to the following specifications. M10 hardware to 30-35 ft-lbs and M8 hardware to 15-18 ft-lbs.

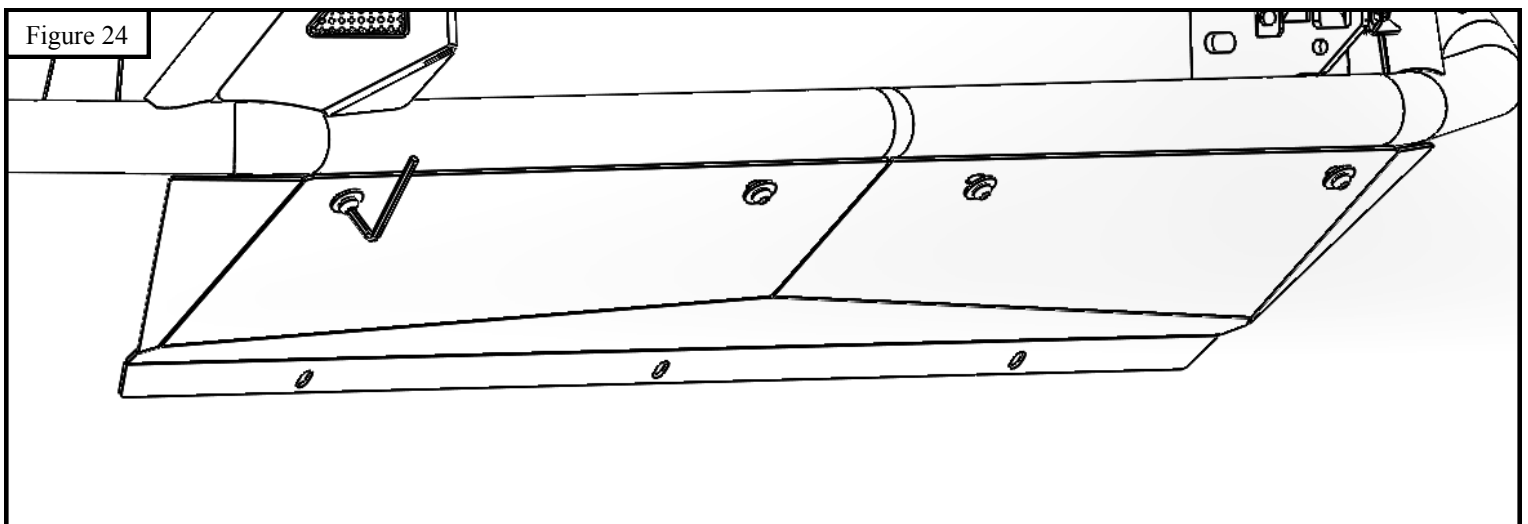

Installation Complete





WARNING



Failure to follow these instructions could lead to death, personal injury, and / or property damage.

FASTENERS:

All Westin supplied fasteners must be utilized and installed in accordance with the installation instructions and apply torque to the specifications as defined. **DOUBLE CHECK ALL FASTENERS BEFORE INITIAL USE, AND PERIODICALLY IN THE FUTURE TO ENSURE PROPER FUNCTION AND SAFETY.**

DRILLING:

Most Westin products do not require drilling for installation. If drilling is defined as required, use caution when drilling a vehicle. **FAILURE TO REVIEW AN AREA TO BE DRILLED MAY RESULT IN PERSONAL INJURY AND/OR INJURY TO OTHERS AS WELL AS VEHICLE DAMAGE.**

EYE PROTECTION:

ALWAYS WEAR SAFETY GLASSES OR GOGGLES DURING THE INSTALLATION PROCESS TO AVOID PERSONAL INJURY.

MAXIMUM TOWING/CARRYING CAPACITY:

The Westin Receiver Hitches will have a visible tow rating label affixed directly on the product. User should never exceed the vehicle manufacturers maximum tow and weight rating regardless of the capacity of the hitch. **FAILURE TO FOLLOW THESE GUIDELINES WILL VOID THE WESTIN WARRANTY AND MAY RESULT IN PERSONAL INJURY AND/OR INJURY TO OTHERS AS WELL AS VEHICLE DAMAGE.**